

Express Series Servo Motor

Express系列交流永磁同步伺服电机

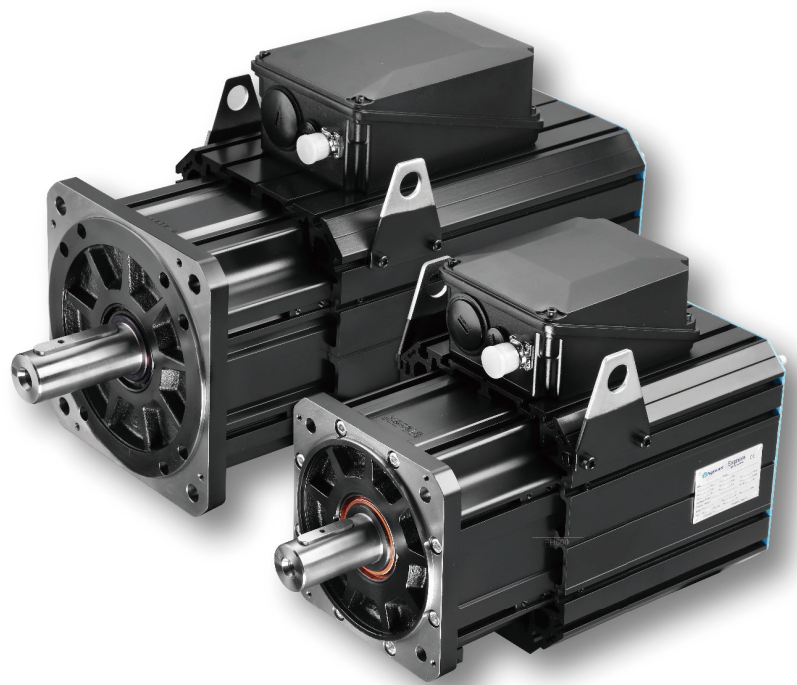

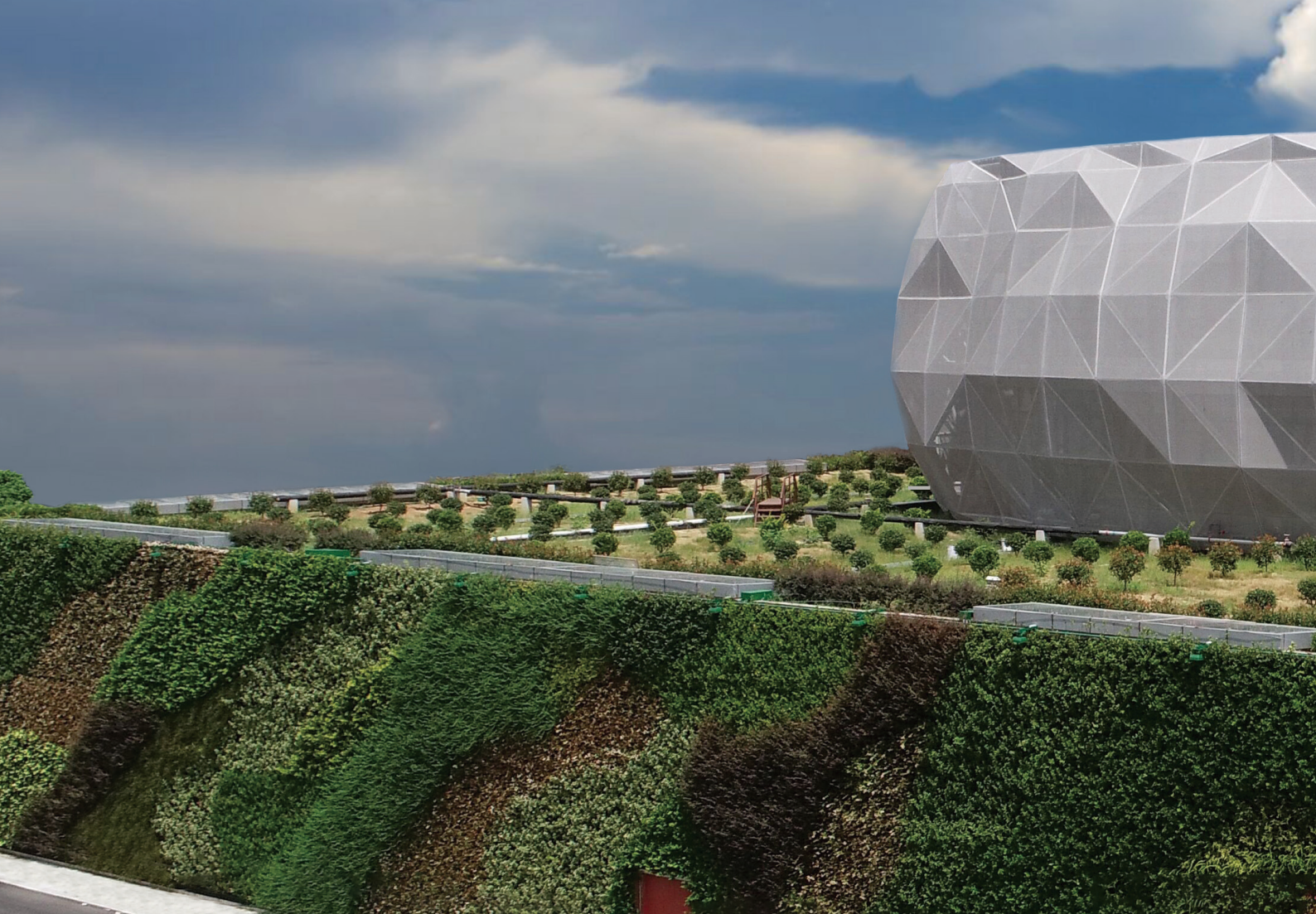

Company Profile 企业简介

宁波菲仕技术股份有限公司（简称：菲仕技术）成立于2001年，由民营控股、先进制造产业投资基金和宁波通商集团等战略投资人参股，公司致力于以“高效节能、精准控制”电驱动技术为核心的创新及产业化，为运动控制和能量转换领域提供系统产品和综合解决方案，经过多年品牌沉淀，菲仕已成为一家集研发、生产、销售为一体，拥有国内外多家控股子公司的集团化创新型高科技企业。

Ningbo Physis Technology Co., Ltd. (hereinafter referred to as Physis) was founded in 2001. Physis always devotes to innovation and industrialization of electrical drive technology, provides servo products and solutions for the field of motion control & energy conversion. After years of brand development and accumulation, Physis becomes a collectivized & innovative high-tech enterprise, which collects together R&D, manufacturing and sales, and has a numbers of domestic and overseas subsidiaries.



6 大生产基地
Manufacturing bases



2 大研发中心
R&D center



17 个海内外分支机构
Subsidiaries



40+ 远销国家和地区
Sold in countries and regions

Global presence 全球布局

立足全国 放眼全球

总部“永动谷”落户中国宁波北仑，在国内产业链完善的宁波、株洲、天津、赣州建立大型生产基地。建立国内外分子公司17家，合作伙伴百余家，形成覆盖全国、面向全球市场的营销服务网络，逐步落地国际化战略。

Physis has established large-scale production bases in Ningbo, Zhuzhou, Tianjin, and Guangzhou, which have a complete domestic industrial chain.

It has established 17 domestic and foreign subsidiaries and more than 100 partners, formed a marketing service network covering the whole country and facing the global market, and gradually implemented the internationalization strategy.

CONTENTS 目录

产品介绍 Products Introduction	01
应用领域 Aplication	02
Express 系列伺服电机代码 Servo Motor Code	03
E010__F 伺服电机规格 Technical Data	04
E010__F 电机性能曲线 Performance Curve	06
E010__C 伺服电机规格 Technical Data	08
E010__C 电机性能曲线 Performance Curve	10
E012__F 伺服电机规格 Technical Data	12
E012__F 电机性能曲线 Performance Curve	14
E013__F 伺服电机规格 Technical Data	16
E013__F 电机性能曲线 Performance Curve	18
E013__C 伺服电机规格 Technical Data	20
E013__C 电机性能曲线 Performance Curve	22
E018__F 伺服电机规格 Technical Data	24
E018__F 电机性能曲线 Performance Curve	26
E018__C 伺服电机规格 Technical Data	28
E018__C 电机性能曲线 Performance Curve	30
电源 Power	32
电机接线 Motor Connection	34
联系我们 Contact Information	35

Products Introduction

产品介绍

菲仕研发的新一代高性能伺服电机，该系列电机拥有更高的功率密度，更好的伺服响应速度和过载输出特性，特别适合需要高速响应和短时过载要求高的应用场合，如高速节能注塑机、压铸机等。

额定功率范围：7.9kW~337.2kW

额定扭矩范围：150Nm~2200Nm

峰值扭矩范围：150Nm~3500Nm

Express Series Servo Motor

Express series servo motor is a new generation of high performance servo motor that has higher power density, higher response speed and good overload output characteristic. Specially suitable for some applications which need high requirements of high speed response and short-time overload, such as high speed energy-saving injection molding machine, die-casting machine, etc.

Rated power range : 7.9kW~337.2kW

Rated torque range : 150Nm~2200Nm

Peak torque range : 150Nm~3500Nm

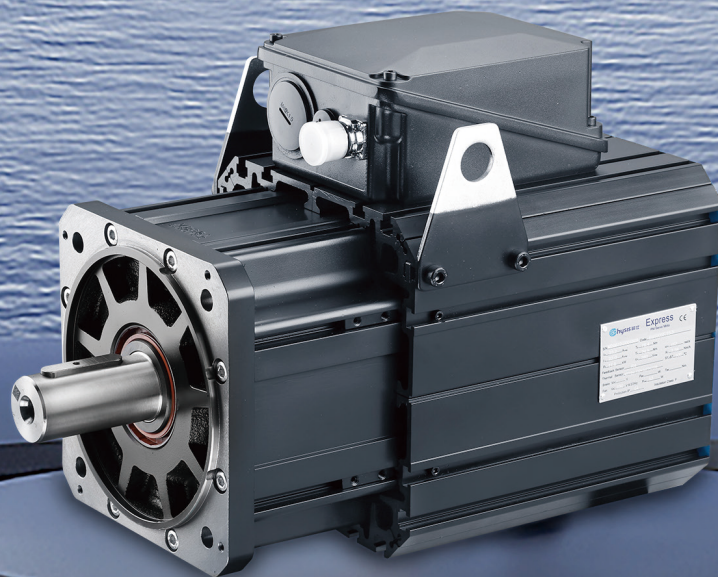

Application 应用领域

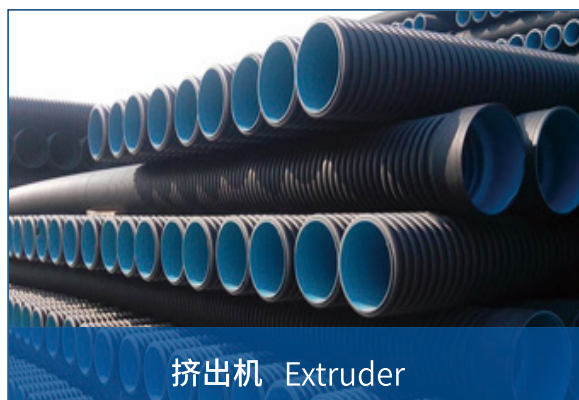
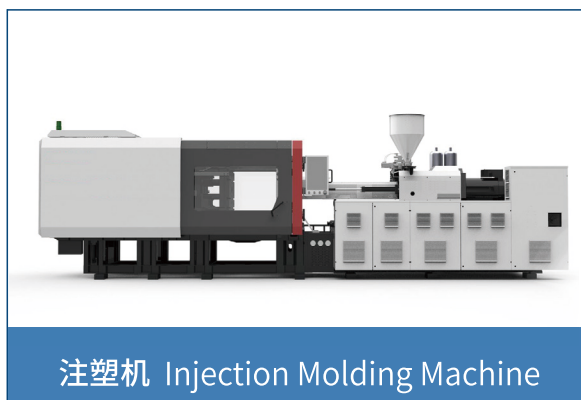

E 0 1 0 0 7 F 2 0 3 R 4 0 Y 0 K b 1 - T F

电机类型 Series Identify	框号 Size	冷却方式 Cooling	额定转速 Rated Speed	额定电压 Rated Voltage	编码器 Sensor Identify	制动器 Brake	接线方式 Connection	转轴 Shaft	底板 Mounting Feet	接线盒位置 Position of Terminal Box	出线孔方向 Direction of Cable Hole
-------------------------	------------	-----------------	---------------------	-----------------------	------------------------	--------------	--------------------	-------------	---------------------	-----------------------------------	----------------------------------

1004, 1005, 1007, 1008,
1010, 1012 1013, 1215,
1220, 1225, 1230, 1235,
1806, 1808, 1809, 1811,
1813, 1805

F = 强制风冷
Fan cooling
C = 水冷却
Water cooling

数字 *100 = 1500 rpm, 2000 rpm

3 = 380 Vac

R4 = 旋转变压器, 1 对极, BRX
Resolver, 1X - BRX

0 = 无制动器
Without brake

Y0 = 电源接线端子, 信号航空插座
Signal circular connector

00 = 无底板
Without feet
b1 = 标准底板
Standard feet

K = 带键槽, 标准键
Shaft with key

轴伸方向看
Look from the direction
of shaft
T = 接线盒在上
Terminal box on top
L = 接线盒在左
Terminal box on the
left
R = 接线盒在右
Terminal box on the
right

F = 出线孔朝前
Cable hole
in front
B = 出线孔朝后
Cable hole
in the back

代码示例 :

E01007F203R40Y0Kb1-TF

E0 系列, 框号 1007, 强制风冷, 额定转速 2000rpm, 电压等级 380Vac, 旋转变压器, 1 对极, BRX, 无制动器, 电源接线端子, 信号航空插座, 伸出轴带键, 标准底板, 轴伸方向看, 接线盒朝上, 出线孔朝前。

Code Example:

E01007F203R40Y0Kb1-TF

E0 series motor, size 1007, servo fan cooling, 2000rpm, 380Vac, resolver, 1X - BRX, without brake, signal circular connector, shaft with key, standard feet, look from the direction of motor shaft, terminal box on top, cable hole in front.

Express 系列伺服电机规格 (E010__F)

电机型号 Motor Code		E01004F			E01005F			E01007F			E01008F			E01010F			E01012F			E01013F		
额定转速 Rated Speed	wn [rpm]	1500	1700	2000	1500	1700	2000	1500	1700	2000	1500	1700	2000	1500	1700	2000	1500	1700	2000	1500	1700	2000
额定频率 Rated Freq	Fn [Hz]	100	113	133	100	113	133	100	113	133	100	113	133	100	113	133	100	113	133	100	113	133
极数 Number of poles	2p	8																				
最大速度 Max Speed	wmax [rpm]	3500																				
最大频率 Max Freq	Fmax [Hz]	233																				
堵转电流 Stall Current	Io [A]	15	18	20	24	28	31	31	35	42	42	45	52	48	57	62	56	62	77	61	68	77
额定电流 Rated Current	In [A]	15	17	19	23	26	29	29	32	38	39	41	47	45	52	56	52	57	69	57	62	69
堵转扭矩 Stall Torque	To [Nm]	53			78			106			132			158			183			208		
额定扭矩 Rated Torque	Tn [Nm]	50	50	50	75	74	73	100	99	97	124	123	121	148	146	143	171	168	165	193	190	187
额定功率 Rated Power	Pn [kW]	7.9	9.0	10	12	13	15	16	18	20	20	22	25	23	26	30	27	30	34	30	34	39
扭矩常数 Torque Constant	Kt [Nm/A]	3.43	2.91	2.57	3.38	2.86	2.60	3.46	3.12	2.60	3.25	3.03	2.60	3.38	2.86	2.60	3.33	3.03	2.42	3.46	3.12	2.77
反电动势 Back EMF	EMF [V/krpm]	208	176	156	204	173	157	210	189	157	197	183	157	204	173	157	202	183	147	210	189	168
绕组线电阻 Winding Resistance	Rw [ohm]	1.67	1.13	0.892	0.825	0.546	0.465	0.543	0.451	0.322	0.37	0.31	0.233	0.319	0.216	0.179	0.244	0.200	0.133	0.222	0.176	0.145
直轴线电感 Direct Inductance	Ld [mH]	18.2	13.1	10.2	11.5	8.2	6.8	9.1	7.4	5.1	6.4	5.6	4.1	5.8	4.1	3.4	4.8	4.0	2.5	4.5	3.7	2.9
交轴线电感 Quadrature Inductance	Lq [mH]	42.7	30.9	24.0	27.1	19.4	16.0	21.4	17.3	12.0	15.0	13.1	9.6	13.5	9.7	8.0	11.3	9.3	6.0	10.7	8.6	6.8
最大电流 Max Current	Imax [A]	50	59	66	80	91	100	100	112	135	135	144	170	155	182	200	183	200	250	200	222	250
最大扭矩 Max Torque	Tmax [Nm]	145			222			297			371			445			520			594		
转动惯量 Rotor Inertia	Jm [kgcm ²]	56			80			103			126			150			173			196		
电机重量 Weight	M [kg]	40			47			54			61			68			75			82		

驱动器电压 Vdrive: 380Vac

直流母线电压 Vdcbus : 537Vdc

载波频率 PWM frequency: ≥ 4 kHz

温升 DT : 100K

环境温度 Tamb : 30°C

制动器的机械参数 / Technical Data of the Holding Brake		
制动扭矩 Holding Torque	MBr [Nm]	140
额定电压 (±10%) Rated Voltage(±10%)	Ubr [Vdc]	24
额定电流 Rated Current	Ibr [A]	2.3
重量 Mass	MBr [Kg]	11
惯量 nertia	JBr [Kgcm ²]	56
电机增加的长度 Additional Motor Length	Length [mm]	65

	B	L
E01004F	267	342
E01005F	285	378
E01007F	312	414
E01008F	354	450
E01010F	396	486
E01012F	400	527
E01013F	471	558

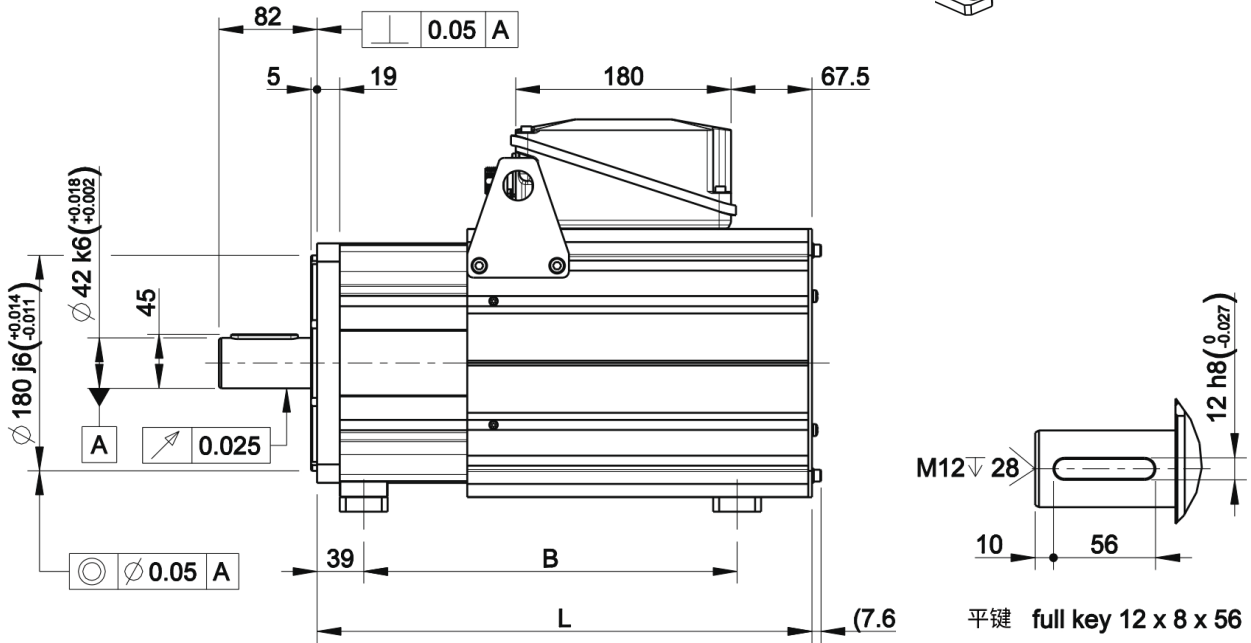
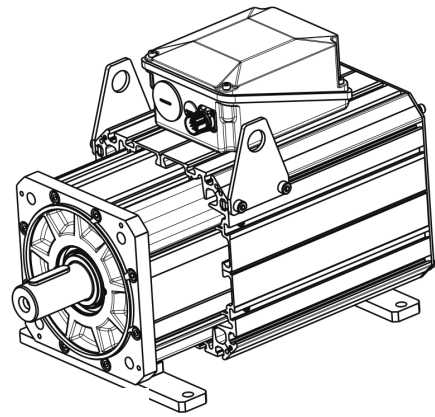

平键 full key 12 x 8 x 56

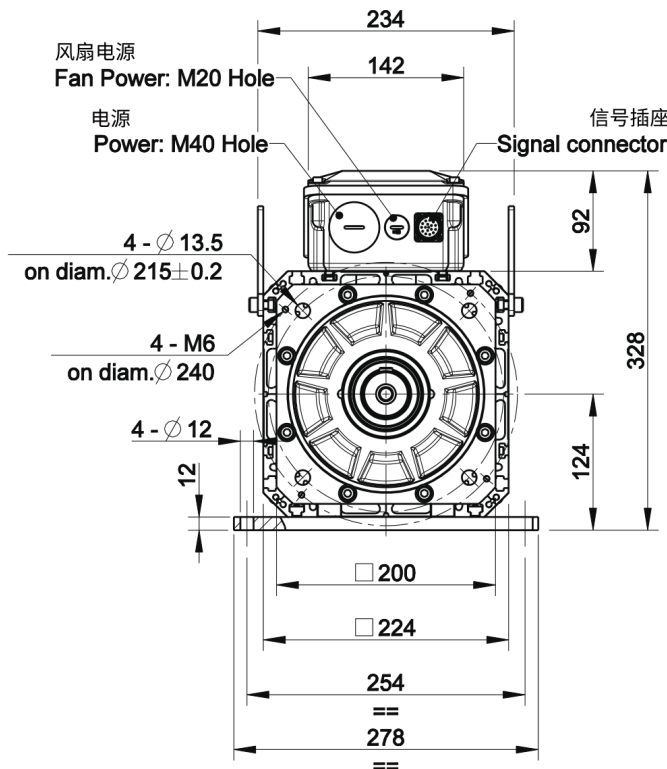

针脚号 PIN	线色 WIRE COLOR	定义 FUNCTION
1	n.c.	n.c.
2	n.c.	n.c.
3	n.c.	n.c.
4	YELLOW 黄	SIN-
5	RED 红	COS+
6	BLACK 黑	COS-
7	RED / WHITE 红 / 白	RESX+
8	BROWN 棕	KTY+
9	WHITE 白	KTY-
10	YELLOW / WHITE 黄 / 白	RESX-
11	n.c.	n.c.
12	n.c.	n.c.
13	n.c.	n.c.
14	BLUE 蓝	SIN+
15	n.c.	n.c.
16	BLUE 蓝	PTC+
17	BLUE 蓝	PTC-

信号插座
Signal Connector
M23 Size 1-17 Pin

旋转变压器 Resolver : 1X-BRX

Performance Curve 电机性能曲线 (E010__F)

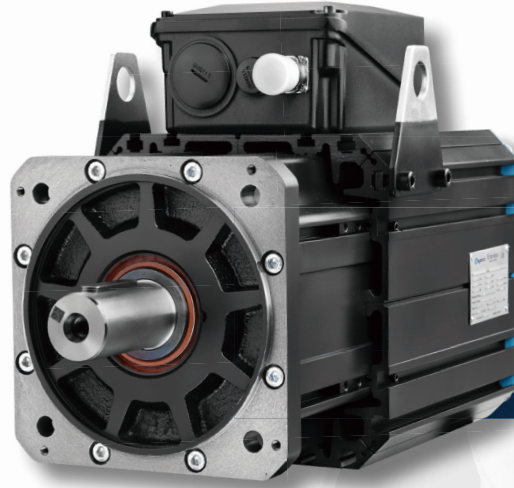

驱动器电压 Vdrive : 380Vac
 直流母线电压 Vdcbus: 537Vdc
 载波频率 PWM frequency: ≥ 4 kHz
 温升 DT: 100K
 环境温度 Tamb: 30°C

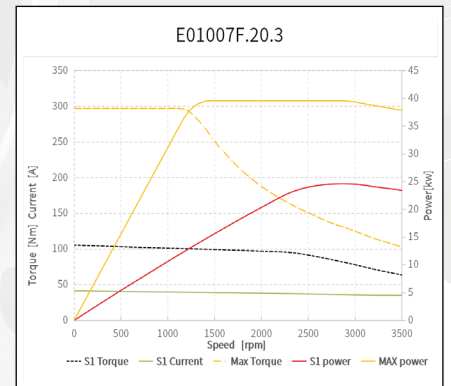
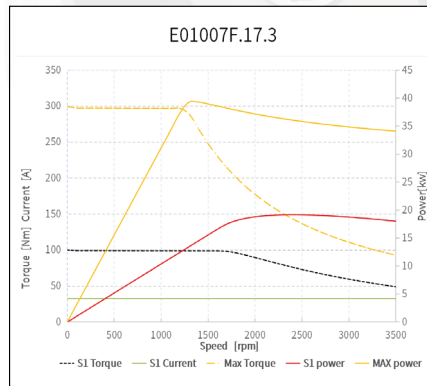
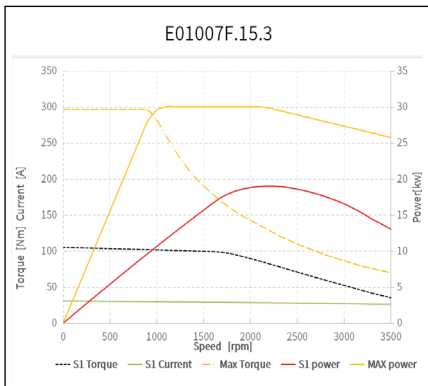
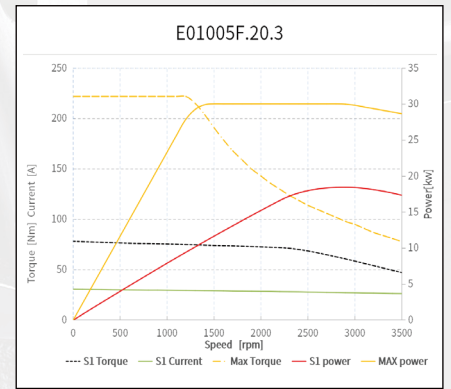
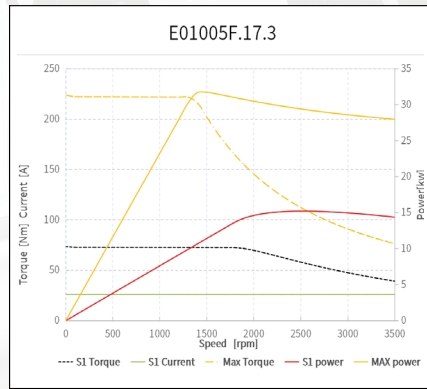
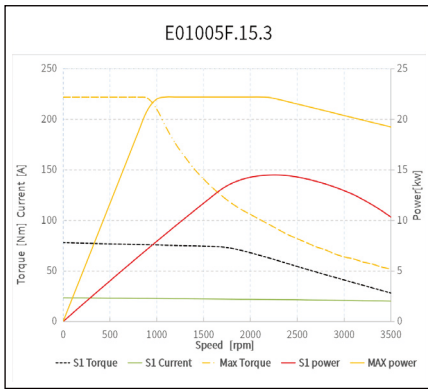
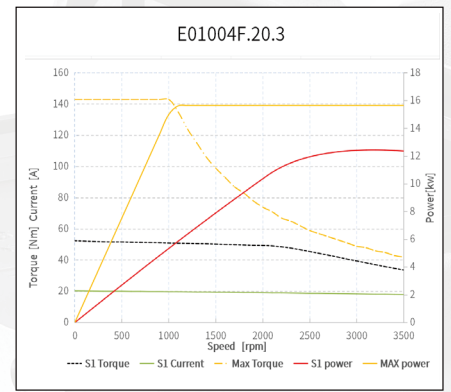
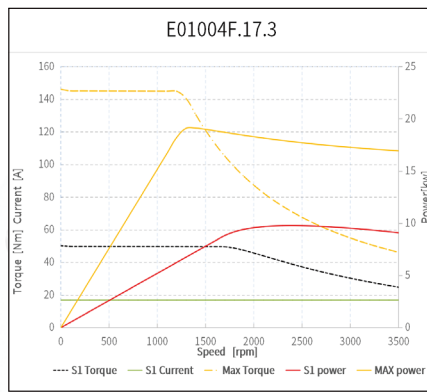
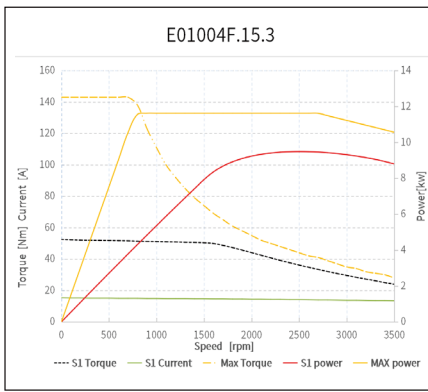

Express 系列伺服电机规格 (E010__C)

电机型号 Motor Code		E01005C			E01007C			E01008C			E01010C			E01012C			E01013C		
额定转速 Rated Speed	wn [rpm]	1500	1700	2000	1500	1700	2000	1500	1700	2000	1500	1700	2000	1500	1700	2000	1500	1700	2000
额定频率 Rated Freq	Fn [Hz]	100	113.3	113.3	100	113.3	133	100	113.3	133	100	113.3	133	100	113.3	133	100	113.3	133
极数 Number of poles	2p	8																	
最大速度 Max Speed	wmax [rpm]	3500																	
最大频率 Max Freq	Fmax [Hz]	233																	
堵转电流 Stall Current	Io [A]	33.39	37.275	42.21	138.6	48.51	54.915	52.5	59.85	69.3	65.1	76.125	84	76.65	84	103.95	85.575	94.5	111.3
额定电流 Rated Current	In [A]	31.8	35.5	40.2	42	46.2	52.3	50	57	66	62	72.5	80	73	80	99	81.5	90	106
堵转扭矩 Stall Torque	To [Nm]	103.4	101.9	99.8	138.6	136.5	136.5	52.5	173.3	171.7	210	207.9	207.9	244.7	243.6	241.5	283.5	278.3	277.2
额定扭矩 Rated Torque	Tn [Nm]	98.5	97	95	132	130	130	165.5	165	163.5	200	198	198	233	232	230	270	265	264
额定功率 Rated Power	Pn [kW]	15.5	17.3	19.9	20.7	23.1	27.2	26	29.4	34.2	31.4	35.2	41.5	36.6	41.3	48.2	42.4	47.2	55.3
冷却水流量 Minimum Flow Rate	Flow [L/min]	10			12			15			17			20			25		
扭矩常数 Torque Constant	Kt [Nm/A]	3.18	2.79	2.41	3.22	2.88	2.54	3.39	2.96	2.54	3.3	2.79	2.54	3.26	2.96	2.37	3.4	3.05	2.55
反电势 Back EMF	EMF [V/krpm]	192.5	169	146	195	174.5	154	205.4	179.5	154	200	169	154	197.7	179.5	143.5	205.4	184.5	154
绕组线电阻 Winding Resistance	Rw [ohm]	0.6958	0.5683	0.4	0.4748	0.3897	0.2982	0.3974	0.3	0.2185	0.2971	0.2133	0.1724	0.2388	0.1975	0.1243	0.2136	0.173	0.1202
直轴线电感 Direct Inductance	Ld [mH]	8.18	6.33	4.73	6.27	5.02	3.91	5.55	4.25	3.12	4.39	3.14	2.6	3.66	3.01	1.93	3.46	2.8	1.94
交轴线电感 Quadrature Inductance	Lq [mH]	16.82	13.03	9.73	12.91	10.34	8.05	11.45	8.76	6.44	9.05	6.47	5.36	7.58	6.23	4	7.18	5.79	4.02
最大电流 Max Current	I _{max} [A]	80	91	100	100	112	135	135	144	170	155	182	200	183	200	250	200	222	250
最大扭矩 Max Torque	T _{max} [Nm]	222			297			371			445			520			594		
转动惯量 Rotor Inertia	J _m [kgcm ²]	80			103			126			150			173			196		
电机重量 Weight	M [kg]	48			56			63			70			79			86		

驱动器电压 Vdrive: 380Vac

直流母线电压 Vdcbus : 537Vdc

载波频率 PWM frequency: ≥ 4kHz

温升 DT : 100K

环境温度 Tamb : 30°C

制动器的机械参数 / Technical Data of the Holding Brake		
制动转矩 Holding Torque	MBr [Nm]	140
额定电压 (± 10%) Rated Voltage(±10%)	Ubr [Vdc]	24
额定电流 Rated Current	Ibr [A]	2.3
重量 Mass	MBr [Kg]	11
惯量 nertia	JBr [Kgcm ²]	56
电机增加的长度 Additional Motor Length	Length [mm]	65

	B	L
E01005C	200	311
E01007C	200	347
E01008C	236	383
E01010C	271	419
E01012C	306	460
E01013C	306	495.5

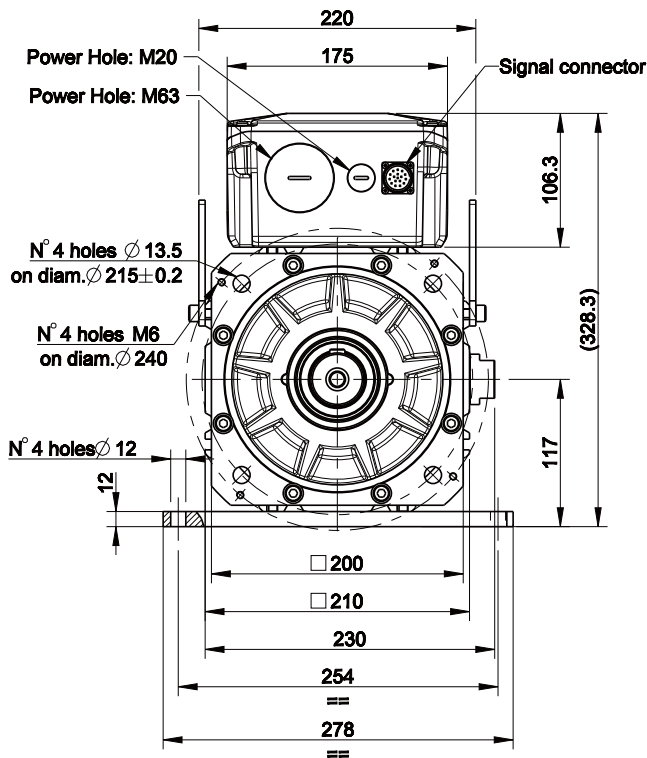
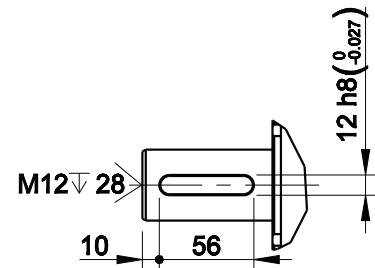
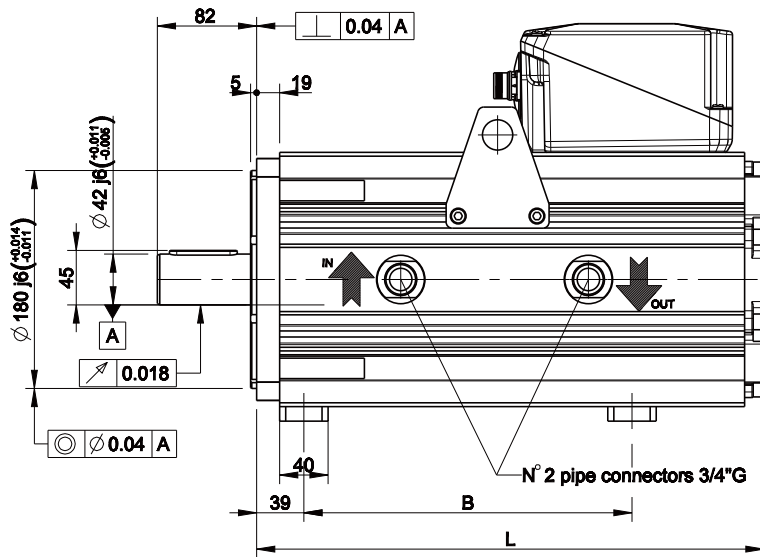
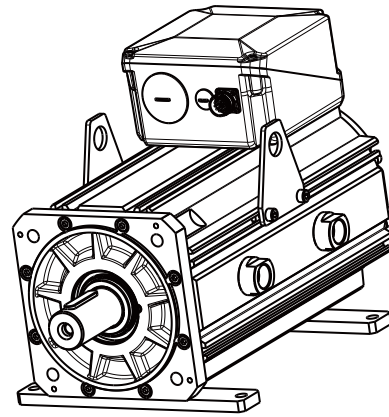

针脚号 PIN	线色 WIRE COLOR	定义 FUNCTION
1	n.c.	n.c.
2	n.c.	n.c.
3	n.c.	n.c.
4	YELLOW 黄	SIN-
5	RED 红	COS+
6	BLACK 黑	COS-
7	RED / WHITE 红 / 白	RESX+
8	BROWN 棕	KTY+
9	WHITE 白	KTY-
10	YELLOW / WHITE 黄 / 白	RESX-
11	n.c.	n.c.
12	n.c.	n.c.
13	n.c.	n.c.
14	BLUE 蓝	SIN+
15	n.c.	n.c.
16	BLUE 蓝	PTC+
17	BLUE 蓝	PTC-

信号插座
Signal Connector
M23 Size 1-17 Pin

旋转变压器 Resolver : 1X-BRX

Performance Curve 电机性能曲线 (E010__C)

驱动器电压 Vdrive : 380Vac
 直流母线电压 Vdcbus: 537Vdc
 载波频率 PWM frequency: $\geq 4\text{kHz}$
 温升 DT: 100K
 环境温度 Tamb: 30°C

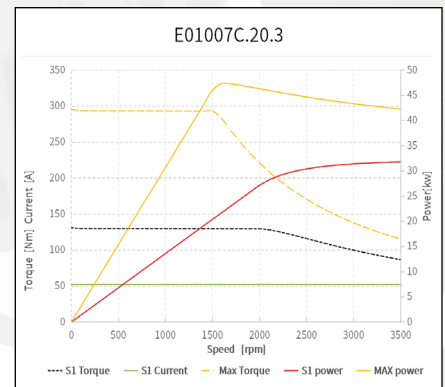
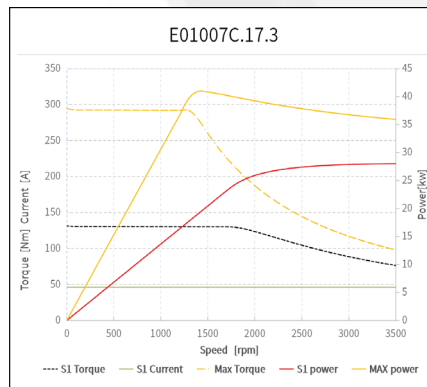
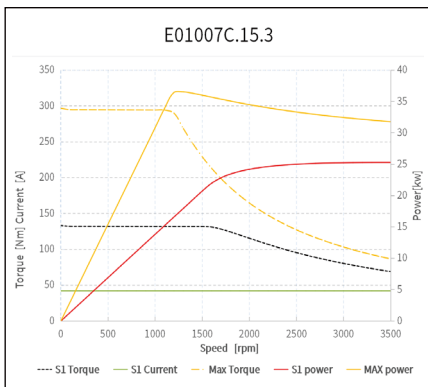
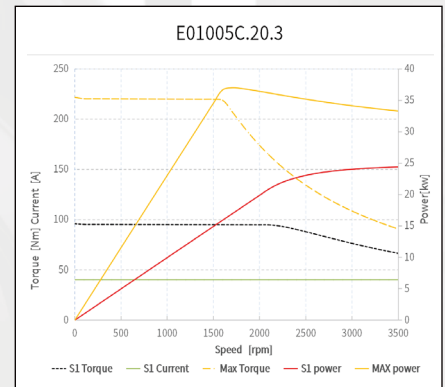
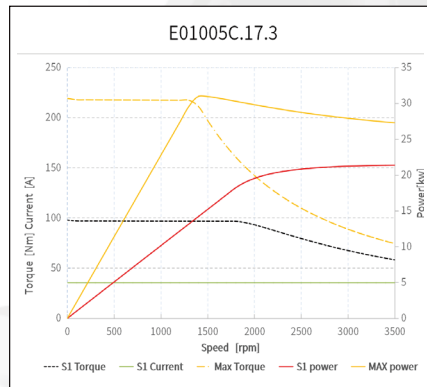
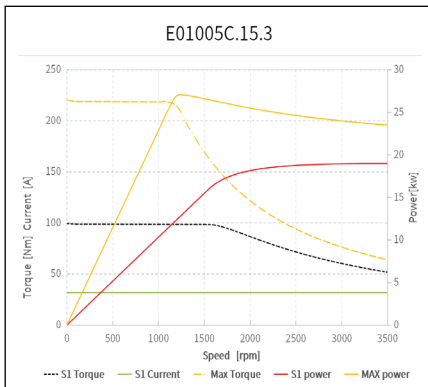

Express 系列伺服电机规格 (E012__F)

电机型号 Motor Code		E01215F			E01220F			E01225F			E01230F			E01235F		
额定转速 Rated Speed	wn [rpm]	1500	1700	2000	1500	1700	2000	1500	1700	2000	1500	1700	2000	1500	1700	2000
额定频率 Rated Freq	Fn [Hz]	100	113	133	100	113	133	100	113	133	100	113	133	100	113	133
极数 Number of poles	2p	8														
最大速度 Max Speed	wmax [rpm]	3500														
最大频率 Max Freq	Fmax [Hz]	233														
堵转电流 Stall Current	Io [A]	70	77	85	85	96	109	95	109	127	108	126	151	125	150	187
额定电流 Rated Current	In [A]	64	70	75	78	86	95	86	96	109	100	114	134	115	135	164
堵转扭矩 Stall Torque	To [Nm]	224			279			332			378			428		
额定扭矩 Rated Torque	Tn [Nm]	206	203	197	255	250	243	300	294	285	351	344	336	395	387	377
额定功率 Rated Power	Pn [kW]	32	36	41	40	45	51	47	52	60	55	61	70	62	69	79
扭矩常数 Torque Constant	Kt [Nm/A]	3.27	2.98	2.67	3.34	2.98	2.60	3.57	3.13	2.67	3.64	3.13	2.60	3.57	2.98	2.38
反电动势 Back EMF	EMF [V/ krpm]	198	180	162	203	180	158	216	189	162	221	189	158	216	180	144
绕组线电阻 Winding Resistance	Rw [ohm]	0.157	0.123	0.106	0.123	0.096	0.074	0.110	0.085	0.062	0.095	0.068	0.049	0.078	0.054	0.034
直轴电感 Direct Inductance	Ld [mH]	4.1	3.4	2.7	3.4	2.7	2.1	3.2	2.5	1.8	2.9	2.1	1.5	2.4	1.7	1.1
交轴电感 Quadrature Inductance	Lq [mH]	9.6	7.9	6.4	8.0	6.3	4.9	7.6	5.8	4.3	6.8	5.0	3.5	5.7	1.0	2.5
最大电流 Max Current	Imax [A]	155	171	190	190	214	245	210	240	280	240	280	335	280	336	420
最大扭矩 Max Torque	Tmax [Nm]	467			585			700			800			920		
转动惯量 Rotor Inertia	Jm [kgcm ²]	253			310			370			427			485		
电机重量 Weight	M [kg]	102			116			130			144			158		

驱动器电压 Vdrive: 380Vac

直流母线电压 Vdcbus: 537Vdc

载波频率 PWM frequency: ≥ 4 kHz

温升 DT: 100K

环境温度 Tamb : 30°C

	B	L
E01215F	400	539
E01220F	450	589
E01225F	500	639
E01230F	550	689
E01235F	600	739

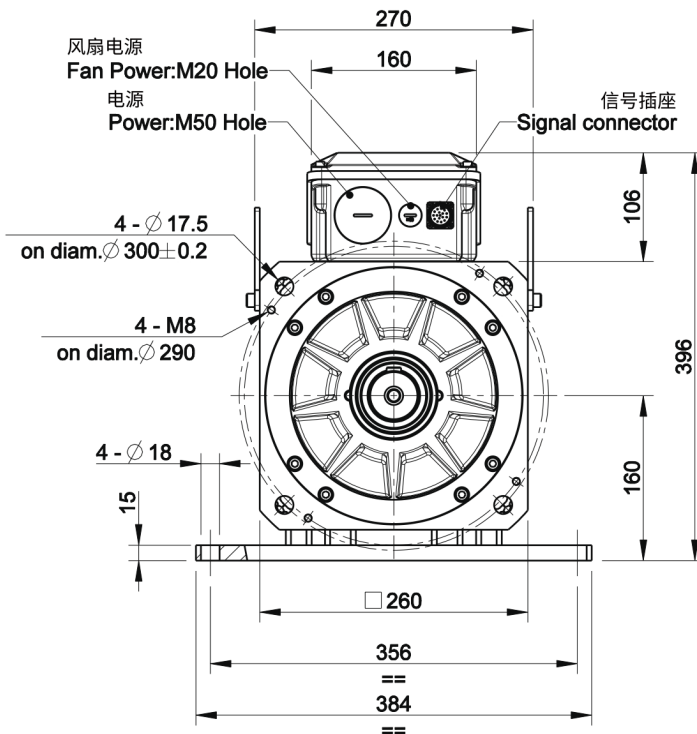
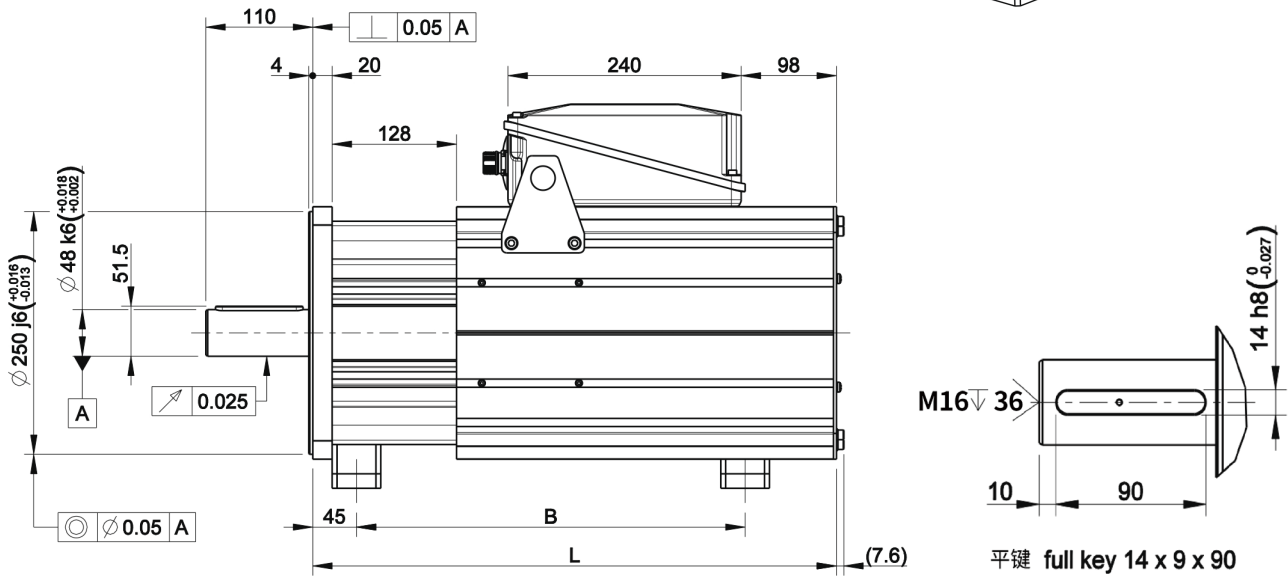
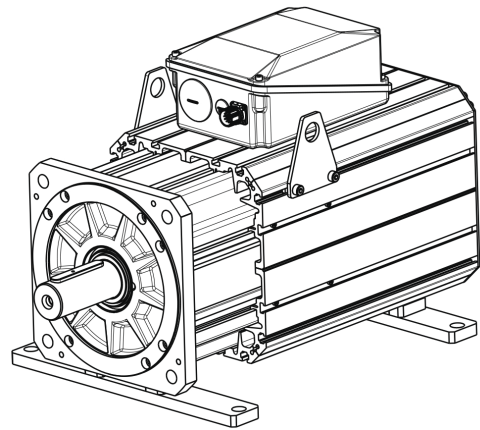

针脚号 PIN	线色 WIRE COLOR	定义 FUNCTION
1	n.c.	n.c.
2	n.c.	n.c.
3	n.c.	n.c.
4	YELLOW 黄	SIN-
5	RED 红	COS+
6	BLACK 黑	COS-
7	RED / WHITE 红 / 白	RESX+
8	BROWN 棕	KTY+
9	WHITE 白	KTY-
10	YELLOW / WHITE 黄 / 白	RESX-
11	n.c.	n.c.
12	n.c.	n.c.
13	n.c.	n.c.
14	BLUE 蓝	SIN+
15	n.c.	n.c.
16	BLUE 蓝	PTC+
17	BLUE 蓝	PTC-

信号插座
Signal Connector
M23 Size 1-17 Pin

旋转变压器 Resolver : 1X-BRX

Performance Curve 电机性能曲线 (E012__F)

驱动器电压 Vdrive: 380Vac
 直流母线电压 Vdcbus: 537Vdc
 载波频率 PWM frequency: $\geq 4\text{kHz}$
 温升 DT: 100K
 环境温度 Tamb: 30°C

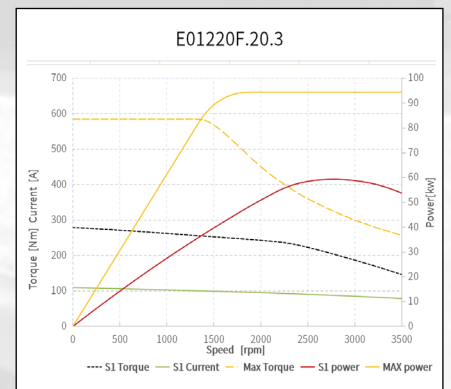
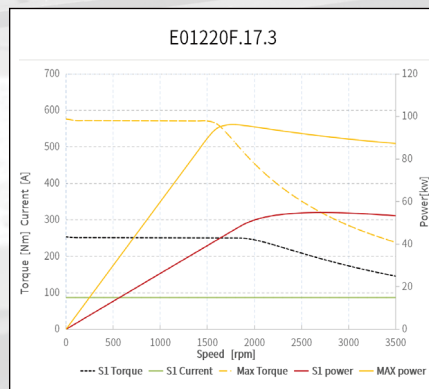
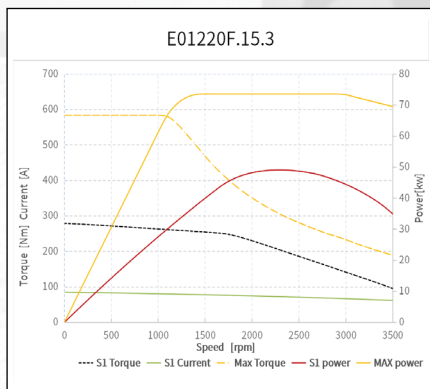
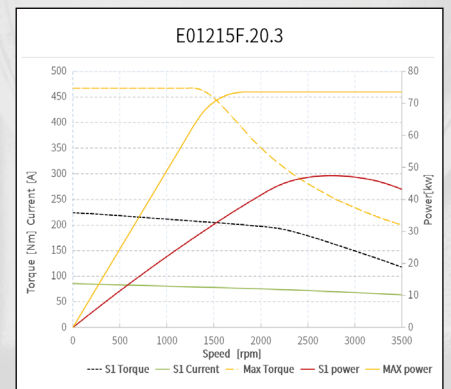
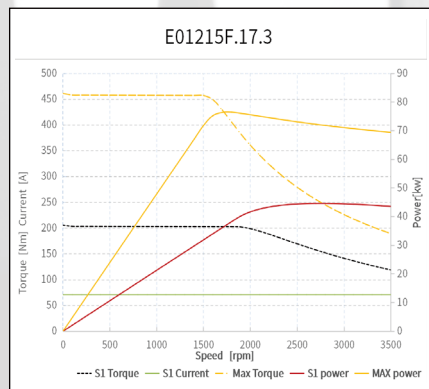
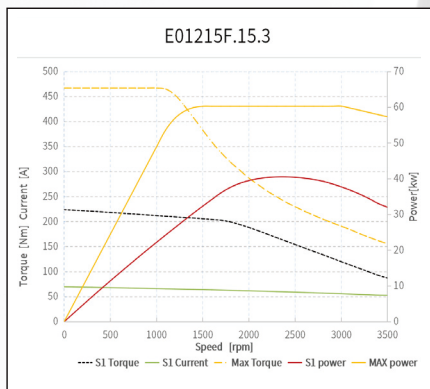
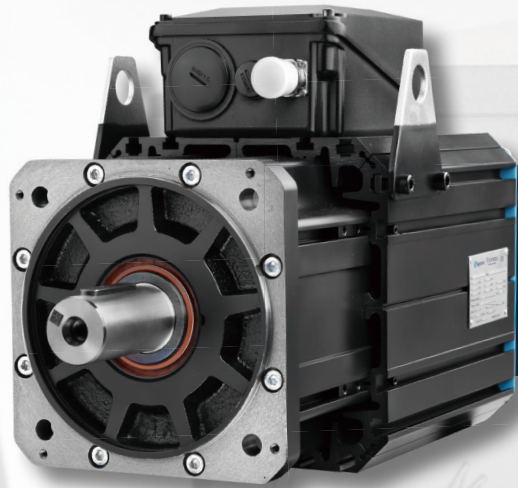

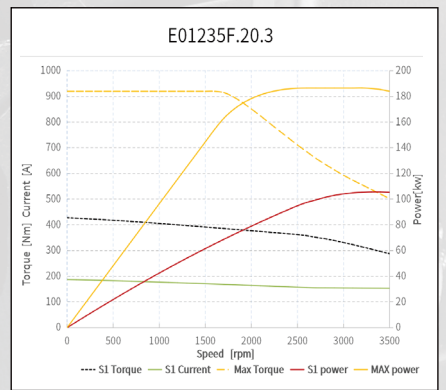
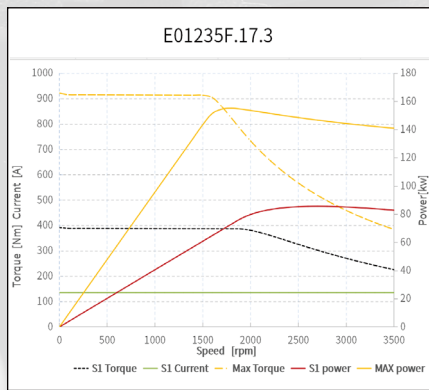
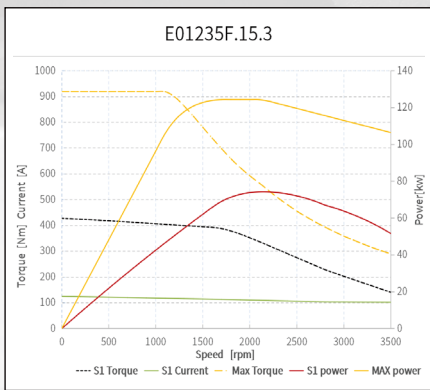
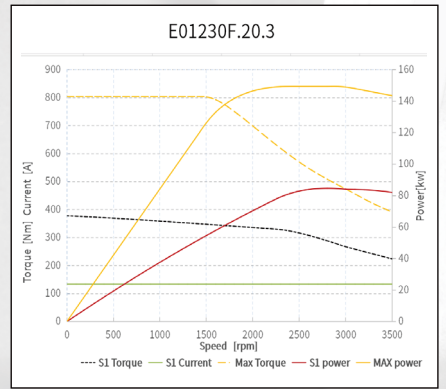
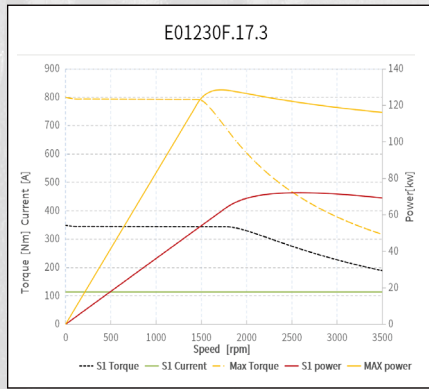
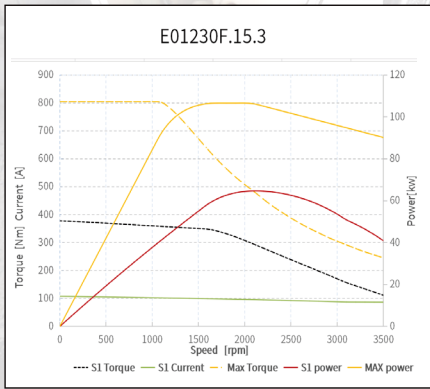
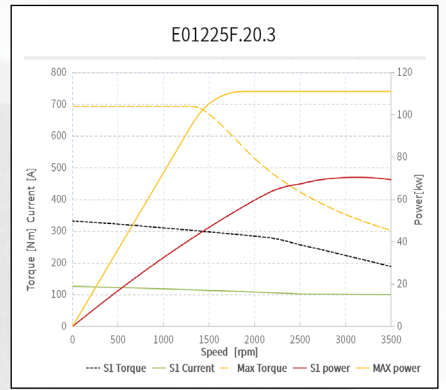
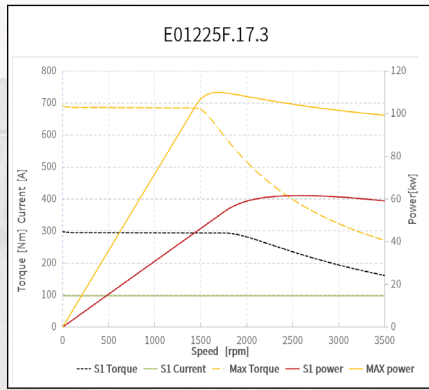
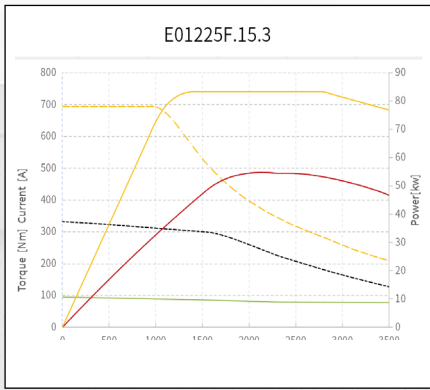

Express 系列伺服电机规格 (E013__F)

电机型号 Motor Code		E01304F			E01306F			E01307F			E01308F			E01309F			E01311F			E01313F		
额定转速 Rated Speed	wn [rpm]	1000	1500	2000	1000	1500	2000	1000	1500	2000	1000	1500	2000	1000	1500	2000	1000	1500	2000	1000	1500	2000
额定频率 Rated Freq	Fn [Hz]	66.67	100	133.3	66.67	100	133.3	66.67	100	133.3	66.67	100	133.3	66.67	100	133.3	66.67	100	133.3	66.67	100	133.3
极数 Number of poles	2p	8																				
最大速度 Max Speed	wmax [rpm]	3500																				
最大频率 Max Freq	Fmax [Hz]	233																				
堵转电流 Stall Current	Io [A]	36.75	55.65	70.35	56.7	81.9	105	68.25	97.65	132.3	76.65	110.25	147	84	131.25	180.6	115.5	155.4	215.25	118.65	184.8	252
额定电流 Rated Current	In [A]	35	53	67	54	78	100	65	93	126	73	105	140	80	125	172	110	148	205	113	176	240
堵转扭矩 Stall Torque	To [Nm]	194.3	193.2	182.7	294	283.5	273	357	333.9	336	399	383.3	383.3	437.9	427.4	409.5	535.5	519.8	509.3	614.3	609	588
额定扭矩 Rated Torque	Tn [Nm]	185	184	174	280	270	260	340	318	320	380	365	365	417	407	390	510	495	485	585	580	560
额定功率 Rated Power	Pn [kW]	19.4	28.9	36.4	29.3	42.4	54.5	35.6	49.9	67	39.8	57.3	76.4	43.7	63.9	81.7	53.4	77.7	101.6	61.3	91.1	117.3
扭矩常数 Torque Constant	Kt [Nm/A]	4.86	3.24	2.43	4.86	3.24	2.43	4.73	3.19	2.36	4.86	3.24	2.43	4.86	3.03	2.13	4.45	3.16	2.22	4.82	3.06	2.18
反电动势 Back EMF	EMF [V/ krpm]	294.1	196.067	146.9	294.1	196.067	146.9	285.9	192.8	142.95	294.1	195.9	147.15	293.8	183	128.5	269	191	134	291.7	185	132
绕组线电阻 Winding Resistance	Rw [ohm]	0.488	0.216	0.123	0.273	0.126	0.069	0.22	0.096	0.055	0.182	0.083	0.045	0.158	0.065	0.032	0.106	0.053	0.026	0.101	0.042	0.022
直轴线电感 Direct Inductance	Ld [mH]	10.86	4.82	2.35	7.24	3.22	3.7	5.86	2.29	1.47	5.43	2.07	1.25	4.14	1.57	0.76	3	1.44	0.9	2.82	1.15	0.6
交轴线电感 Quadrature Inductance	Lq [mH]	23.56	10.47	5.57	15.71	6.98	1.55	12.73	5.26	3.18	11.78	4.93	2.41	9.57	3.7	1.75	6.3	3.4	1.73	6.59	2.69	1.36
最大电流 Max Current	Imax [A]	89.7	132.5	171.7	139.7	194	268.7	160	229	311	190	257.5	350	193.1	315	450	280	425	580	281	480	670
最大扭矩 Max Torque	Tmax [Nm]	400			600			700			800			900			1100			1300		
转动惯量 Rotor Inertia	Jm [kgcm ²]	440			626			718			811			903			1111			1296		
电机重量 Weight	M [kg]	128			148			158			169			180			230			263		

驱动器电压 Vdrive: 380Vac

直流母线电压 Vdcbus: 537Vdc

载波频率 PWM frequency: ≥ 4kHz

温升 DT: 100K

环境温度 Tamb : 30°C

制动器的机械参数 / Technical Data of the Holding Brake		
制动转矩 Holding Torque	MBr [Nm]	300
额定电压 (±10%) Rated Voltage(±10%)	Ubr [Vdc]	24
额定电流 Rated Current	Ibr [A]	1.74
重量 Mass	MBr [Kg]	18
惯量 Inertia	JBr [Kgcm ²]	200
电机增加的长度 Additional Motor Length	Length [mm]	80

	A1	A2	L1	L2	L3	B1	D1	H1
E01304F	503.5	210	90	35	60	14	48j6	51.5
E01306F	563.5	270	90	35	60	14	48j6	51.5
E01307F	593.5	300	90	35	60	14	48j6	51.5
E01308F	623.5	330	90	35	60	14	48j6	51.5
E01309F	653.5	360	90	35	60	14	48j6	51.5
E01311F	715.5	420	90	37	62	18	60m6	64
E01313F	775.5	480	90	37	62	18	60m6	64

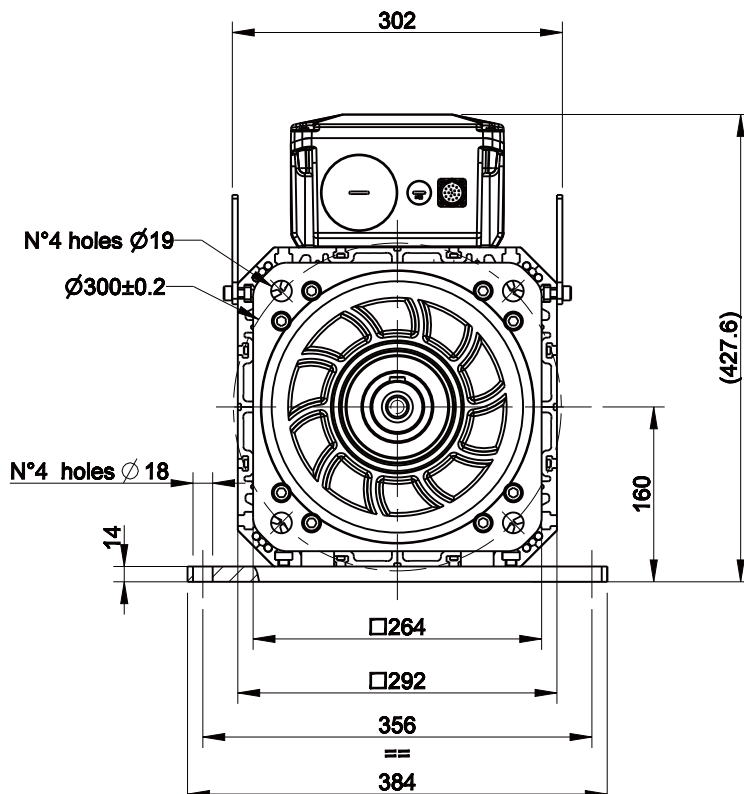
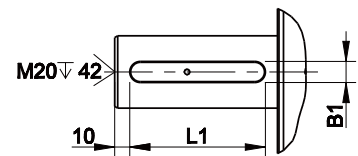
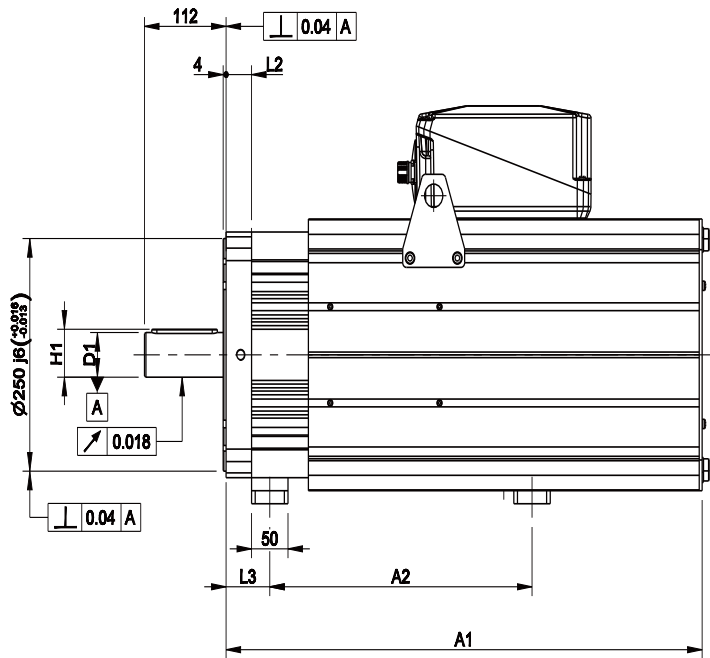
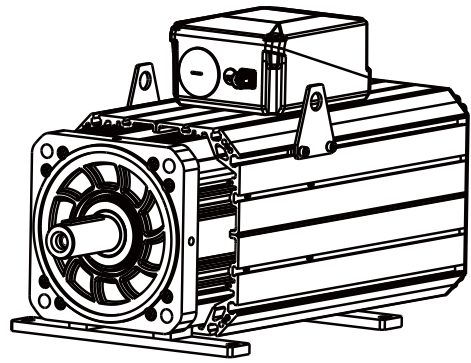

针脚号 PIN	线色 WIRE COLOR	定义 FUNCTION
1	n.c.	n.c.
2	n.c.	n.c.
3	n.c.	n.c.
4	YELLOW 黄	SIN-
5	RED 红	COS+
6	BLACK 黑	COS-
7	RED / WHITE 红 / 白	RESX+
8	BROWN 棕	KTY+
9	WHITE 白	KTY-
10	YELLOW / WHITE 黄 / 白	RESX-
11	n.c.	n.c.
12	n.c.	n.c.
13	n.c.	n.c.
14	BLUE 蓝	SIN+
15	n.c.	n.c.
16	BLUE 蓝	PTC+
17	BLUE 蓝	PTC-

信号插座
Signal Connector
M23 Size 1-17 Pin

旋转变压器 Resolver : 1X-BRX

Performance Curve 电机性能曲线 (E013__F)

驱动器电压 Vdrive: 380Vac
 直流母线电压 Vdcbus: 537Vdc
 载波频率 PWM frequency: $\geq 4\text{kHz}$
 温升 DT: 100K
 环境温度 Tamb: 30°C

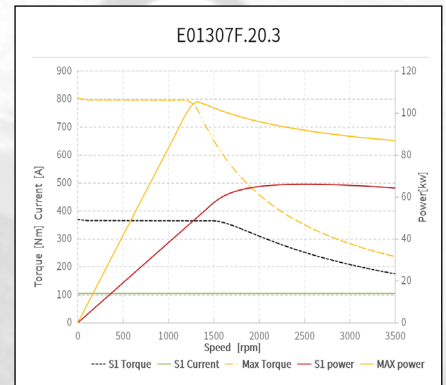
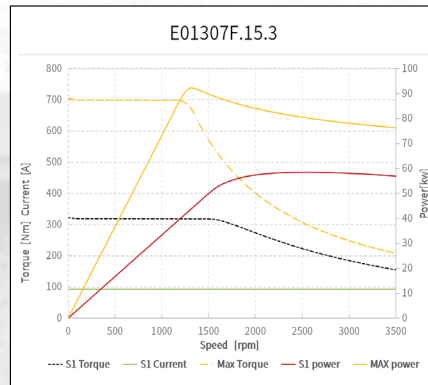
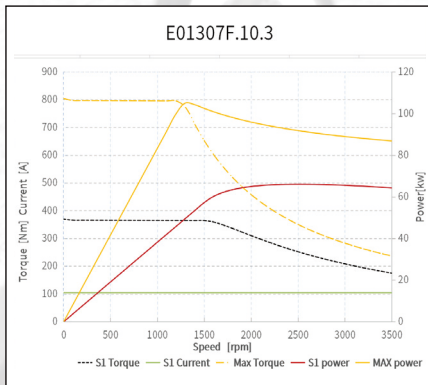
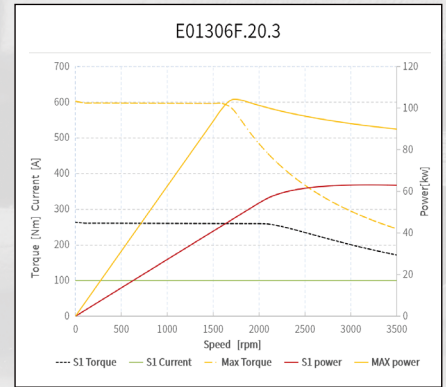
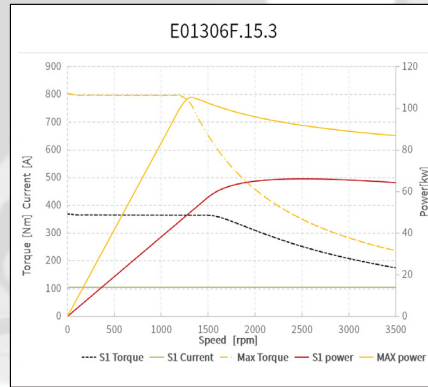
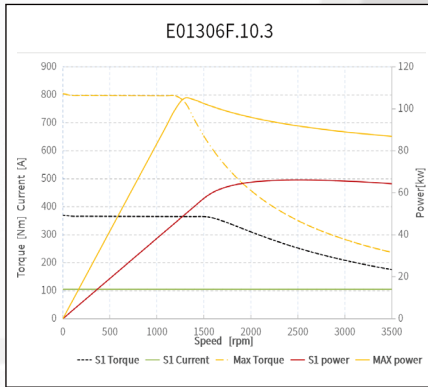
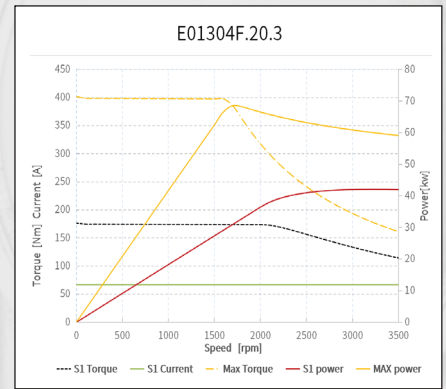
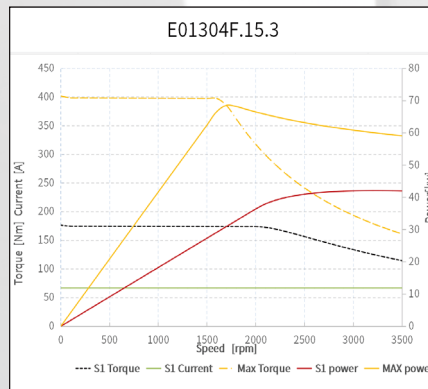
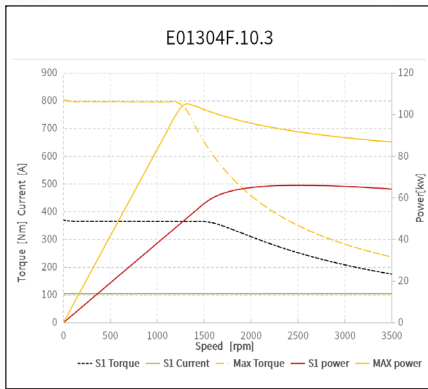
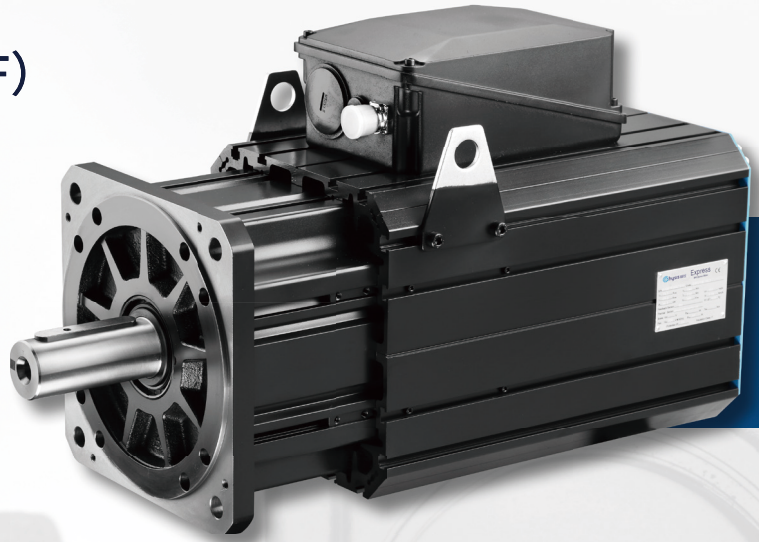

Express 系列伺服电机规格 (E013__C)

电机型号 Motor Code		E01304C			E01306C			E01307C			E01308C			E01309C			E01311C			E01313C		
额定转速 Rated Speed	wn [rpm]	1000	1500	2000	1000	1500	2000	1000	1500	2000	1000	1500	2000	1000	1500	2000	1000	1500	2000	1000	1500	2000
额定频率 Rated Freq	Fn [Hz]	66.67	100	133.3	66.67	100	133.3	66.67	100	133.3	66.67	100	133.3	66.67	100	133.3	66.67	100	133.3	66.67	100	133.3
极数 Number of poles	2p	8																				
最大速度 Max Speed	wmax [rpm]	3500																				
最大频率 Max Freq	Fmax [Hz]	233																				
堵转电流 Stall Current	Io [A]	48.3	72.8	90.3	71.9	112.35	139.65	77.7	118.65	151.2	91.35	141.75	166.95	107.1	156.45	204.75	131.25	194.25	249.9	153.3	216.3	294
额定电流 Rated Current	In [A]	46	69.5	86	68.5	107	133	74	113	144	87	135	159	102	149	195	125	185	238	146	206	280
堵转扭矩 Stall Torque	To [Nm]	228.9	221.6	219.5	342.3	339.2	330.8	392.7	388.5	383.3	446.3	441	432.6	507.2	496.7	488.3	611.1	601.7	589.1	706.7	696.2	682.5
额定扭矩 Rated Torque	Tn [Nm]	218	211	209	326	323	315	374	370	365	425	420	412	483	473	465	582	573	561	673	663	650
额定功率 Rated Power	Pn [kW]	22.8	33.1	43.8	34.1	50.7	66	39.2	58.1	76.4	44.5	66	86.3	50.6	74.3	97.4	60.9	90	117.5	70.5	104.1	136.1
冷却水流量 Minimum Flow Rate	Flow [L/min]	15			18			20			23			25			30			35		
扭矩常数 Torque Constant	Kt [Nm/A]	4.45	2.83	2.29	4.45	2.83	2.23	4.72	3.06	2.36	4.58	2.96	2.43	4.45	3.01	2.25	4.45	2.96	2.23	4.38	3.06	2.18
反电势 Back EMF	EMF [V/krpm]	269.3	171	138.7	269	171	134.7	285.6	185	142.8	277	179	146.9	269	182	136	269	179	134.6	265	185	132
绕组线电阻 Winding Resistance	Rw [ohm]	0.43	0.176	0.111	0.24	0.097	0.058	0.224	0.093	0.053	0.173	0.072	0.049	0.15	0.067	0.038	0.107	0.048	0.026	0.087	0.043	0.022
直轴电感 Direct Inductance	Ld [mH]	8.2	3.2	2.07	5.3	2.15	1.29	5.1	2.2	1.42	4.7	1.8	1.31	4.2	1.81	0.94	3.29	1.33	0.71	2.61	1.16	0.6
交轴电感 Quadrature Inductance	Lq [mH]	18.2	7.5	4.97	12.3	5	3.12	11.6	4.8	3.17	10.7	4.1	3.04	6.7	3.45	2.08	5.73	2.84	1.72	4.98	2.64	1.37
最大电流 Max Current	Imax [A]	89.7	132.5	171.7	139.7	194	268.7	160	229	311	190	257.5	350	193.1	315	450	280	425	580	281	480	670
最大扭矩 Max Torque	Tmax [Nm]	400			600			700			800			900			1100			1300		
转动惯量 Rotor Inertia	Jm [kgcm ²]	440			626			718			811			903			1111			1296		
电机重量 Weight	M [kg]	123			146			159			179			190			219			241		

驱动器电压 Vdrive: 380Vac
 直流母线电压 Vdcbus: 537Vdc
 载波频率 PWM frequency: ≥ 4kHz
 温升 DT: 100K
 环境温度 Tamb : 30°C

制动器的机械参数 / Technical Data of the Holding Brake		
制动转矩 Holding Torque	MBr [Nm]	300
额定电压 (±10%) Rated Voltage (±10%)	Ubr [Vdc]	24
额定电流 Rated Current	Ibr [A]	1.74
重量 Mass	MBr [Kg]	18
惯量 Inertia	JBr [Kgcm ²]	200
电机增加的长度 Additional Motor Length	Length [mm]	80

	A1	A2	L1	L2	L3	B1	D1	H1
E01304C	376	190	90	35	60	14	48j6	51.5
E01306C	436	250	90	35	60	14	48j6	51.5
E01307C	466	280	90	35	60	14	48j6	51.5
E01308C	496	310	90	35	60	14	48j6	51.5
E01309C	526	340	90	35	60	14	48j6	51.5
E01311C	588	400	90	37	62	18	60m6	64
E01313C	648	460	90	37	62	18	60m6	64

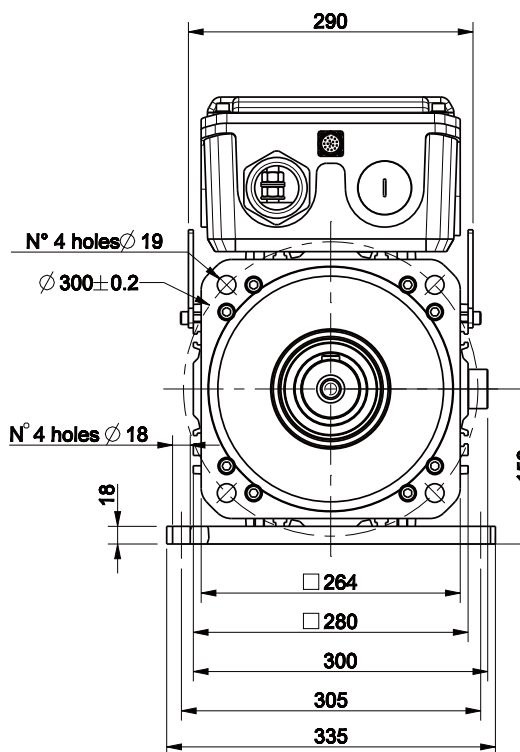
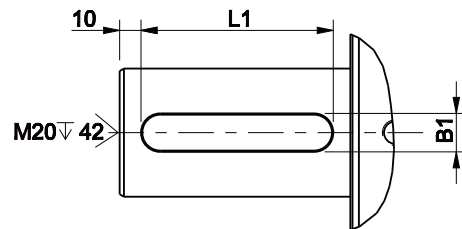
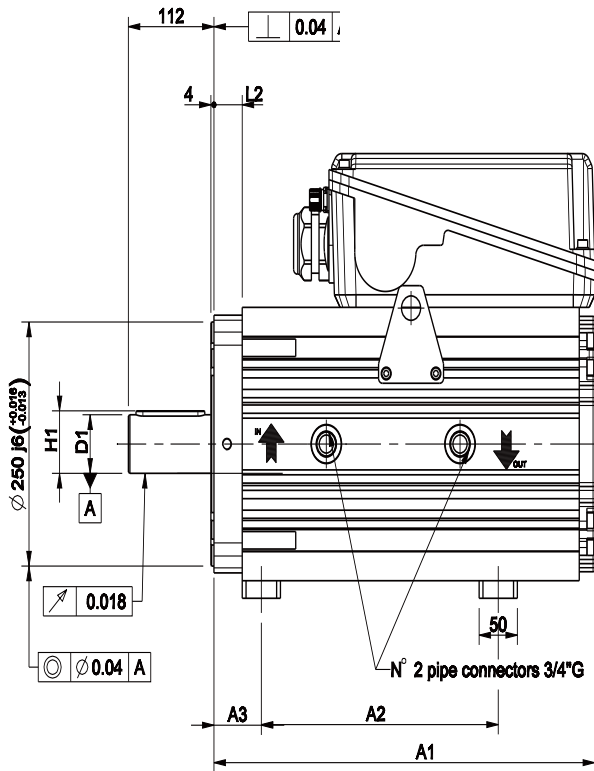
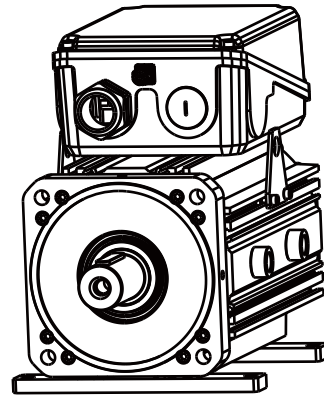

针脚号 PIN	线色 WIRE COLOR	定义 FUNCTION
1	n.c.	n.c.
2	n.c.	n.c.
3	n.c.	n.c.
4	YELLOW 黄	SIN-
5	RED 红	COS+
6	BLACK 黑	COS-
7	RED / WHITE 红 / 白	RESX+
8	BROWN 棕	KTY+
9	WHITE 白	KTY-
10	YELLOW / WHITE 黄 / 白	RESX-
11	n.c.	n.c.
12	n.c.	n.c.
13	n.c.	n.c.
14	BLUE 蓝	SIN+
15	n.c.	n.c.
16	BLUE 蓝	PTC+
17	BLUE 蓝	PTC-

信号插座
Signal Connector
M23 Size 1-17 Pin

旋转变压器 Resolver : 1X-BRX

Performance Curve 电机性能曲线 (E013__C)

驱动器电压 Vdrive: 380Vac
 直流母线电压 Vdcbus: 537Vdc
 载波频率 PWM frequency: $\geq 4\text{kHz}$
 温升 DT: 100K
 环境温度 Tamb: 30°C

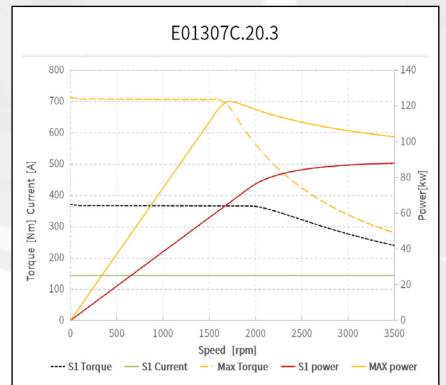
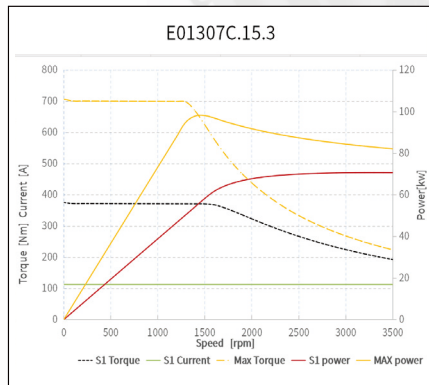
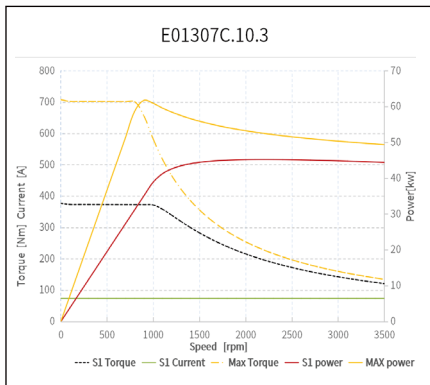
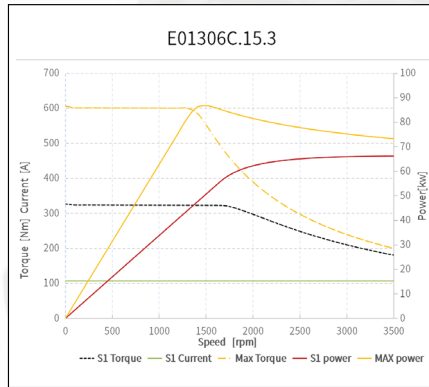
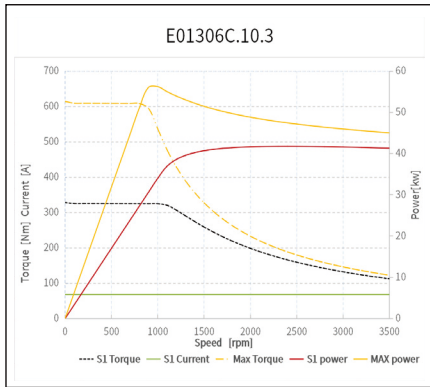
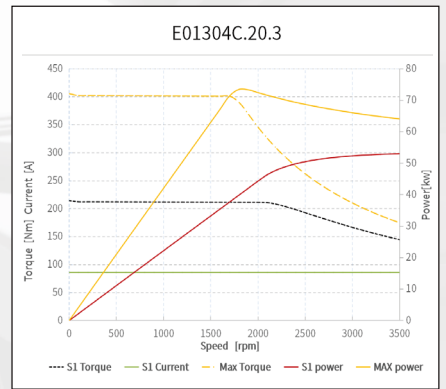
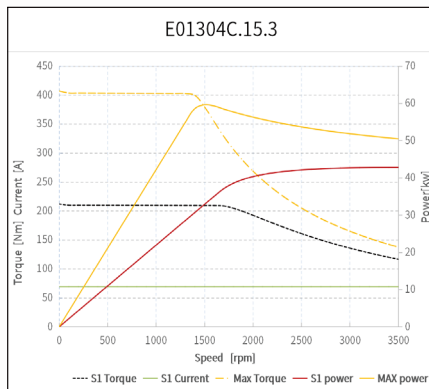
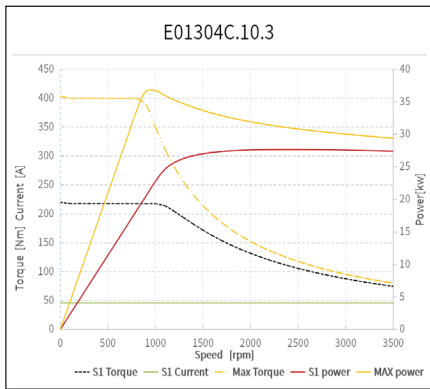
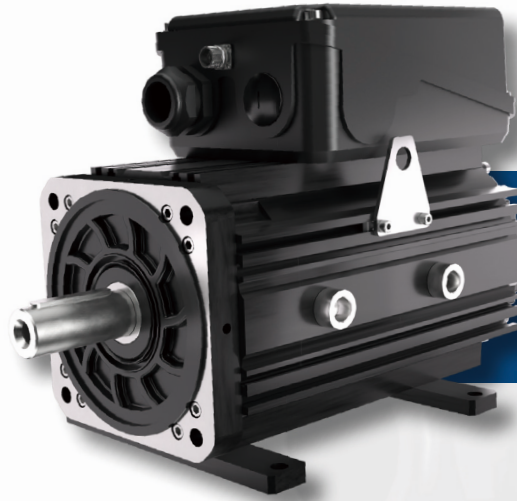

Express 系列伺服电机规格 (E018__F)

电机型号 Motor Code		E01806F			E01808F			E01809F			E01811F			E01813F			E01815F			E01817F		
额定转速 Rated Speed	wn [rpm]	1000	1200	1500	1000	1200	1500	1000	1200	1500	1000	1200	1500	1000	1200	1500	1000	1200	1500	1000	1200	1500
额定频率 Rated Freq	Fn [Hz]	100	120	150	100	120	150	100	120	150	100	120	150	100	120	150	100	120	150	100	120	150
极数 Number of poles	2p	12																				
最大速度 Max Speed	wmax [rpm]	2000	2500	3000	2000	2500	3000	2000	2500	3000	2000	2500	3000	2000	2500	3000	2000	2500	3000	2000	2500	3000
最大频率 Max Freq	Fmax [Hz]	200	250	300	200	250	300	200	250	300	200	250	300	200	250	300	200	250	300	200	250	300
堵转电流 Stall Current	Io [A]	132	152	177	162	187	223	193	218	261	222	267	325	264	325	360	281	353	396	284	370	457
额定电流 Rated Current	In [A]	120	138	161	147	170	203	175	198	237	202	243	295	240	295	327	255	321	360	270	352	415
堵转扭矩 Stall Torque	To [Nm]	651	642	629	829	827	774	966	930	926	1169	1161	1122	1343	1320	1293	1478	1448	1403	1544	1498	1546
额定扭矩 Rated Torque	Tn [Nm]	592	584	572	754	752	704	878	845	842	1063	1055	1020	1221	1200	1175	1344	1316	1275	1470	1427	1405
额定功率 Rated Power	Pn [kW]	62	73	90	79	95	110	92	106	132	111	133	160	128	151	185	141	165	200	154	179	221
扭矩常数 Torque Constant	Kt [Nm/A]	4.76	4.08	3.40	4.83	4.23	3.32	4.76	4.08	3.37	4.97	4.14	3.30	4.90	3.92	3.44	5.09	3.96	3.37	5.34	3.98	3.32
反电动势 Back EMF	EMF [V/krpm]	288	247	206	292	256	201	288	247	204	301	251	199	297	237	208	308	240	204	323	241	201
绕组线电阻 Winding Resistance	Rw [ohm]	0.0903	0.0667	0.05	0.0643	0.0484	0.03	0.0524	0.0384	0.0267	0.044	0.031	0.0198	0.035	0.0224	0.0171	0.032	0.0194	0.015	0.0277	0.0156	0.0108
直轴线电感 Direct Inductance	Ld [mH]	1.66	1.22	0.84	1.26	0.96	0.59	1.09	0.80	0.56	0.95	0.66	0.42	0.79	0.50	0.37	0.73	0.44	0.33	0.65	0.37	0.25
交轴线电感 Quadrature Inductance	Lq [mH]	4.20	3.11	2.17	3.33	2.52	1.56	2.84	2.09	1.45	2.49	1.72	1.10	2.02	1.30	1.00	1.90	1.15	0.86	2.09	0.96	0.66
最大电流 Max Current	Imax [A]	275	315	332	285	330	408	347	405	485	402	483	603	550	685	650	600	765	721	653	870	820
最大扭矩 Max Torque	Tmax [Nm]	1270	1254	1141	1420	1434	1400	1680	1680	1677	2040	2043	2040	2660	2627	2303	2999	3000	2550	3545	3545	2830
转动惯量 Rotor Inertia	Jm [kgcm ²]	3890			5060			5650			6850			7980			9170			10355		
电机重量 Weight	M[kg]	315			357			377			418			460			498			545		

驱动器电压 Vdrive : 380Vac

直流母线电压 Vdcbus : 537Vdc

载波频率 PWM frequency: \geq 4kHz

温升 DT : 100K

环境温度 Tamb : 30°C

	A1	A2	L1	H1	Key
E01806F	682	330	170	80m6	22x14x140
E01808F	742	390	170	80m6	22x14x140
E01809F	772	420	170	80m6	22x14x140
E01811F	832	480	170	80m6(90m6)	22x14x140(25x14x140)
E01813F	892	540	170	90m6	25x14x140
E01815F	962	610	170	90m6	25x14x140
E01817F	1012	660	170	90m6	25x14x140

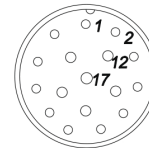
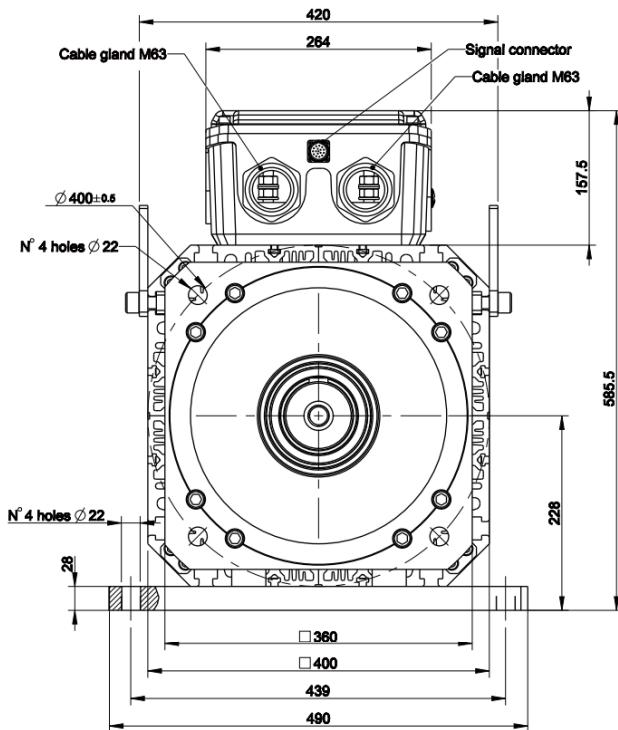
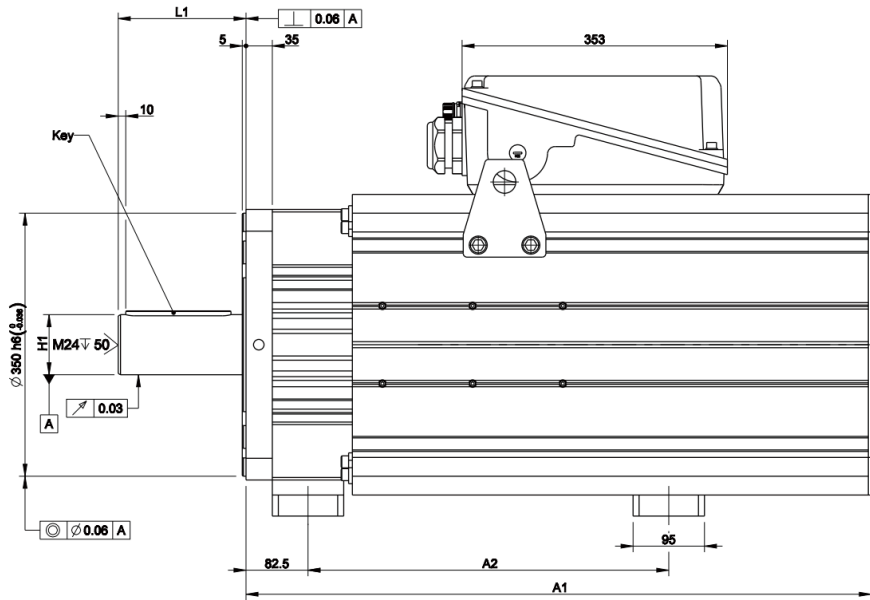
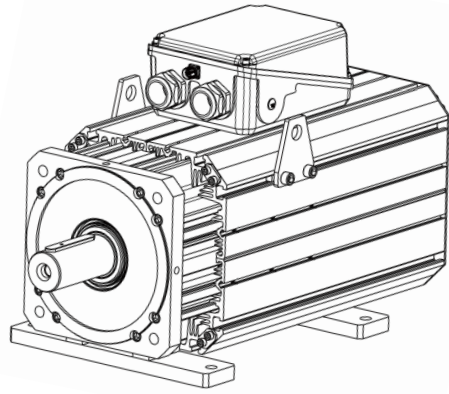

信号插座
Signal Connector
M23 Size 1-17 Pin

针脚号 PIN	线色 WIRE COLOR	定义 FUNCTION
1	n.c.	n.c.
2	n.c.	n.c.
3	n.c.	n.c.
4	YELLOW 黄	SIN-
5	RED 红	COS+
6	BLACK 黑	COS-
7	RED / WHITE 红 / 白	RESX+
8	BROWN 棕	KTY+
9	WHITE 白	KTY-
10	YELLOW / WHITE 黄 / 白	RESX-
11	n.c.	n.c.
12	n.c.	n.c.
13	n.c.	n.c.
14	BLUE 蓝	SIN+
15	n.c.	n.c.
16	BLUE 蓝	PTC+
17	BLUE 蓝	PTC-

旋转变压器 Resolver : 1X-BRX

Performance Curve 电机性能曲线 (E018__F)

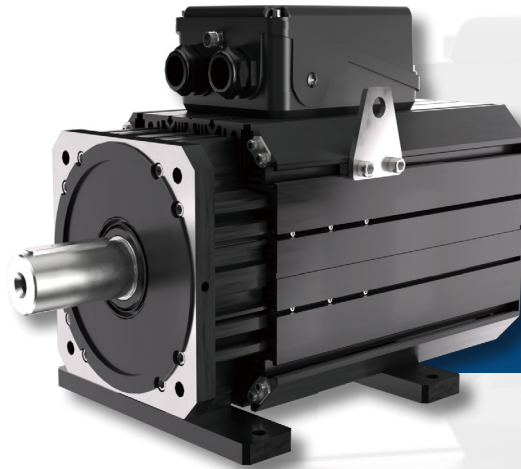

驱动器电压 Vdrive : 380Vac
 直流母线电压 Vdcbus: 537Vdc
 载波频率 PWM frequency: ≥ 4 kHz
 温升 DT: 100K
 环境温度 Tamb: 30°C

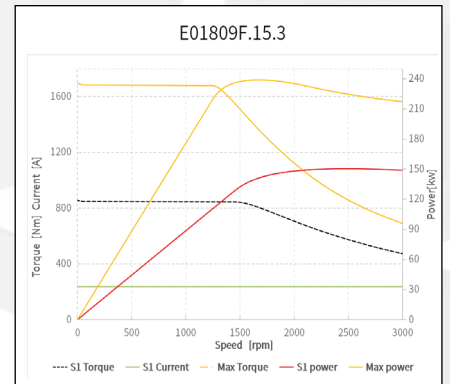
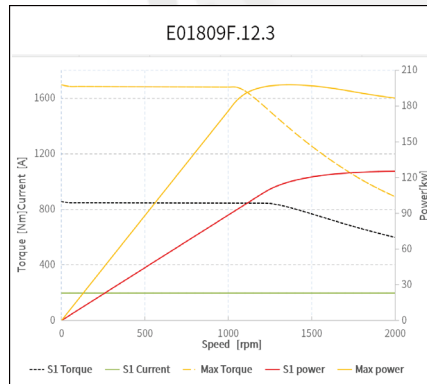
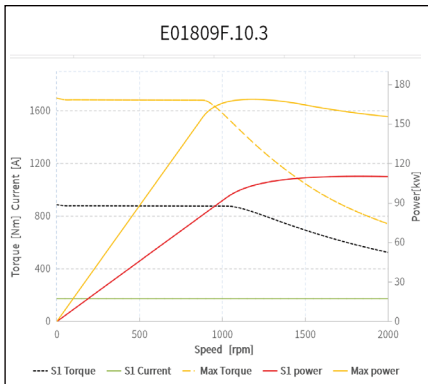
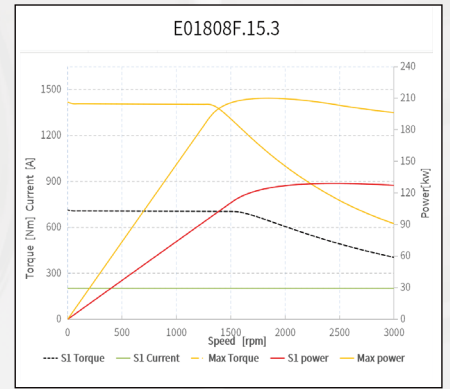
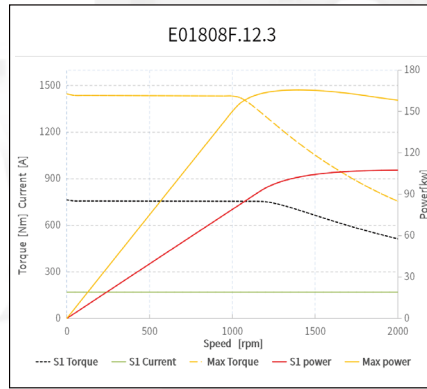
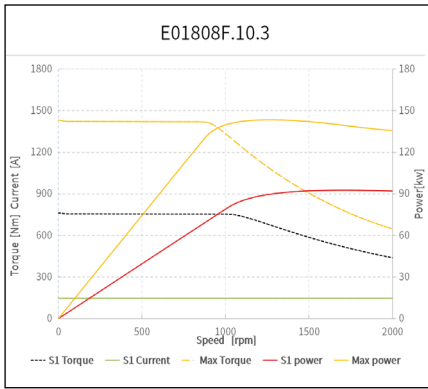
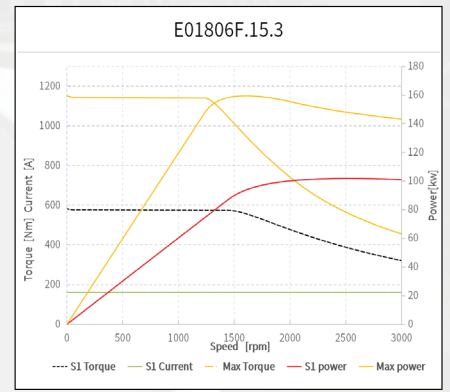
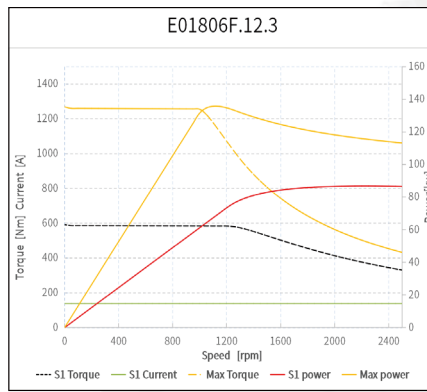
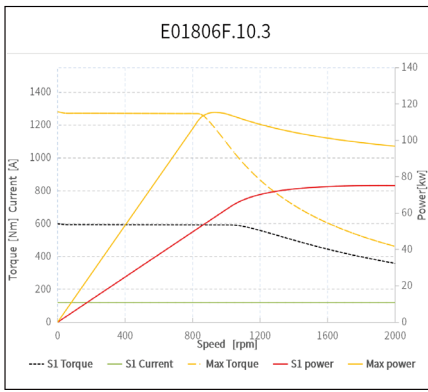

Express 系列伺服电机规格 (E018__C)

电机型号 Motor Code		E01806C			E01808C			E01809C			E01811C			E01813C			E01815C			E01817C		
额定转速 Rated Speed	wn [rpm]	1000	1200	1500	1000	1200	1500	1000	1200	1500	1000	1200	1500	1000	1200	1500	1000	1200	1500	1000	1200	1500
额定频率 Rated Freq	Fn [Hz]	100	120	150	100	120	150	100	120	150	100	120	150	100	120	150	100	120	150	100	120	150
极数 Number of poles	2p	12																				
最大速度 Max Speed	wmax [rpm]	2000	2500	3000	2000	2500	3000	2000	2500	3000	2000	2500	3000	2000	2500	3000	2000	2500	3000	2000	2500	3000
最大频率 Max Freq	Fmax [Hz]	200	250	300	200	250	300	200	250	300	200	250	300	200	250	300	200	250	300	200	250	300
堵转电流 Stall Current	Io [A]	178.5	207.9	251.0	237.3	272.0	351.2	254.1	320.3	389.6	325.5	393.8	498.75	393.8	436.8	577.5	436.8	492.5	577.5	489.3	566.0	672
额定电流 Rated Current	In [A]	170	198	239	226	259	334.5	242	305	371	310	375	475	375	416	550	416	469	550	466	539	640
堵转扭矩 Stall Torque	To [Nm]	842.1	831.1	823.2	1119.3	1108.8	1097.3	1259	1243	1232.7	1548.8	1527.8	1499.75	1811.3	1781.9	1761.9	2064.3	2026.5	2001.3	2312.1	2285.9	2254.4
额定扭矩 Rated Torque	Tn [Nm]	802	791.5	784	1066	1056	1045	1199	1184	1174	1475	1455	1428	1725	1697	1678	1966	1930	1906	2202	2177	2147
额定功率 Rated Power	Pn [kW]	84	99.5	123.1	111.6	132.7	164.1	125.5	148.8	184.4	154.5	182.8	224.3	180.6	213.2	263.6	205.9	242.5	299.4	230.6	273.5	337.2
冷却水流量 Minimum Flow Rate	Flow [L/min]	15			18			18			20			25			25			30		
扭矩常数 Torque Constant	Kt [Nm/A]	4.51	3.83	3.15	4.51	3.9	3	4.73	3.72	3.04	4.54	3.71	2.89	4.39	3.9	2.93	4.51	3.94	3.38	4.47	3.83	3.19
反电动势 Back EMF	EMF [V/krpm]	272.5	231.5	190.5	272.5	236	181.5	286	225	184	274.5	224.5	174.9	265.7	236	177	272.5	238.5	204.4	270	231.5	193
绕组线电阻 Winding Resistance	Rw [ohm]	0.082	0.06	0.040	0.056	0.042	0.025	0.052	0.033	0.022	0.038	0.025	0.016	0.029	0.023	0.013	0.025	0.019	0.014	0.021	0.016	0.011
直轴线电感 Direct Inductance	Ld [mH]	1.49	1.07	0.74	1.11	0.84	0.5	1.08	0.67	0.45	0.82	0.55	0.33	0.65	0.51	0.29	0.59	0.45	0.33	0.51	0.38	0.26
交轴线电感 Quadrature Inductance	Lq [mH]	3.83	2.73	1.88	2.86	2.17	1.29	2.75	1.74	1.17	2.14	1.43	0.85	1.69	1.33	0.75	1.54	1.18	0.87	1.33	0.97	0.68
最大电流 Max Current	Imax [A]	280	329.4	400	373.3	431	560	400	509	622	509	622	800	622.2	700	933	700	800	933.3	800	933	1120
最大扭矩 Max Torque	Tmax [Nm]	1270	1254	1141	1420	1434	1400	1680	1680	1677	2040	2043	2040	2660	2627	2303	2999	3000	2550	3545	3545	2830
转动惯量 Rotor Inertia	Jm [kgcm ²]	3890			5060			5650			6850			7980			9170			10355		
电机重量 Weight	M[kg]	269			306			324			363			397			437			474		

驱动器电压 Vdrive : 380Vac

直流母线电压 Vdcbus : 537Vdc

载波频率 PWM frequency: ≥ 4kHz

温升 DT : 100K

环境温度 Tamb : 30°C

	A1	A2	D1	H1	Key
E01806C	497	270	80m6	85	22x14x140
E01808C	557	330	80m6	85	22x14x140
E01809C	587	360	80m6	55	22x14x140
E01811C	647	420	80m6(90m6)	85(95)	22x14x140(25x14x140)
E01813C	707	480	90m6	95	25x14x140
E01815C	767	540	90m6	95	25x14x140
E01817C	827	600	90m6	95	25x14x140

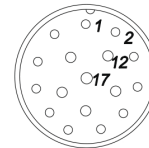
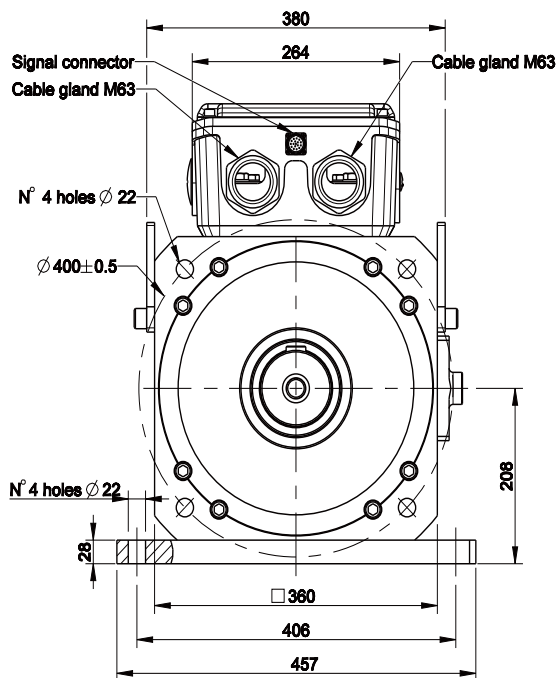
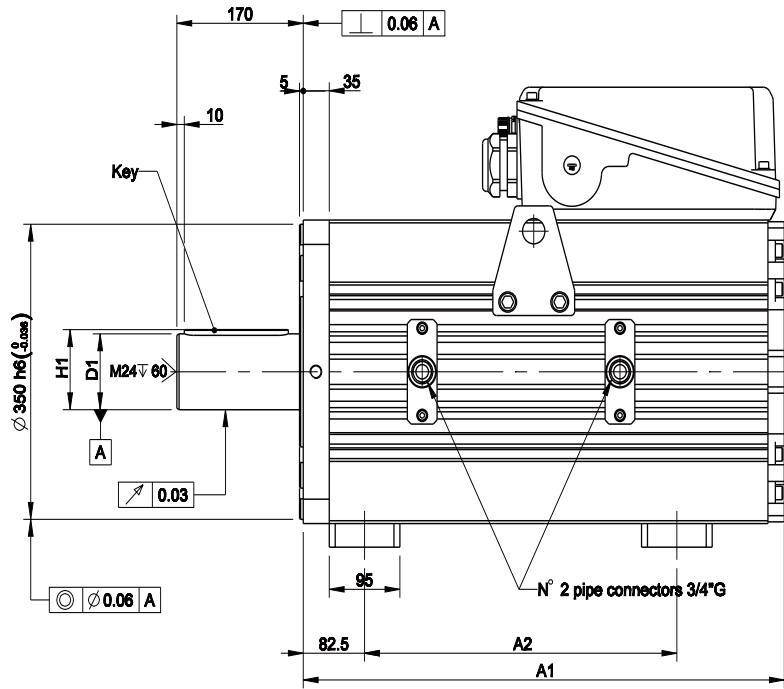
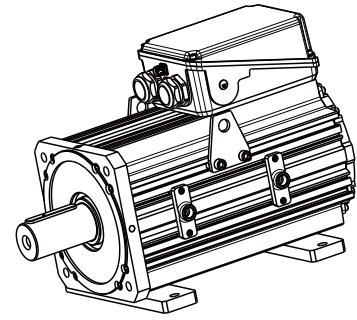

信号插座
Signal Connector
M23 Size 1-17 Pin

针脚号 PIN	线色 WIRE COLOR	定义 FUNCTION
1	n.c.	n.c.
2	n.c.	n.c.
3	n.c.	n.c.
4	YELLOW 黄	SIN-
5	RED 红	COS+
6	BLACK 黑	COS-
7	RED / WHITE 红 / 白	RESX+
8	BROWN 棕	KTY+
9	WHITE 白	KTY-
10	YELLOW / WHITE 黄 / 白	RESX-
11	n.c.	n.c.
12	n.c.	n.c.
13	n.c.	n.c.
14	BLUE 蓝	SIN+
15	n.c.	n.c.
16	BLUE 蓝	PTC+
17	BLUE 蓝	PTC-

旋转变压器 Resolver : 1X-BRX

Performance Curve 电机性能曲线 (E018__C)

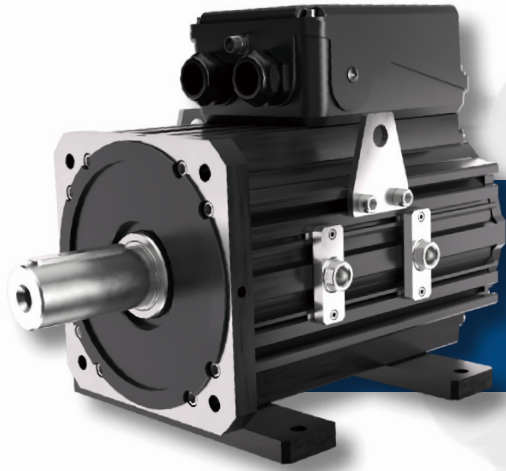

驱动器电压 Vdrive : 380Vac
 直流母线电压 Vdcbus: 537Vdc
 载波频率 PWM frequency: $\geq 4\text{kHz}$
 温升 DT: 100K
 环境温度 Tamb: 30°C

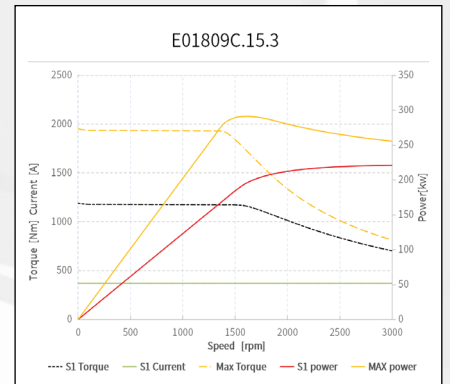
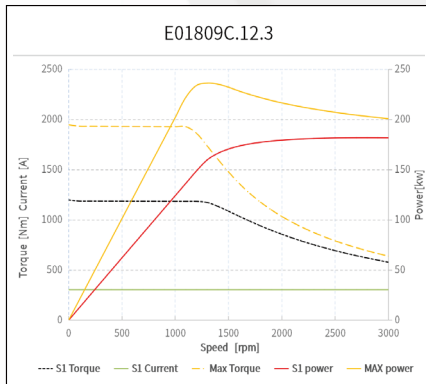
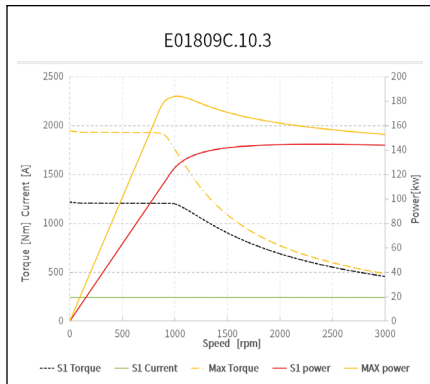
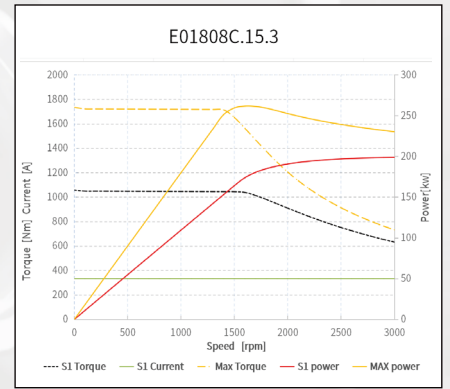
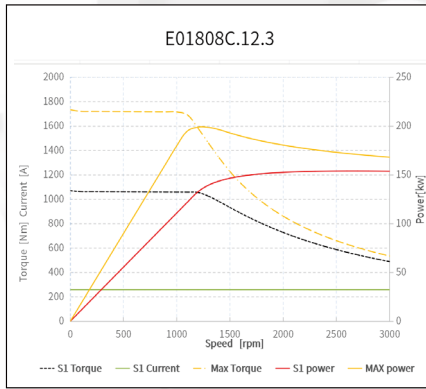
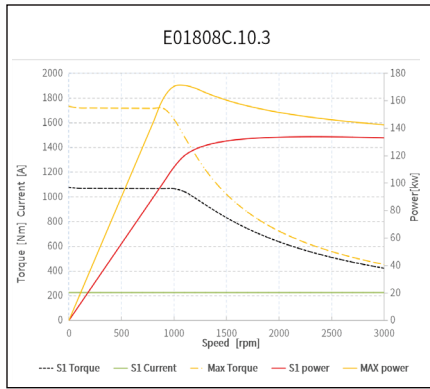
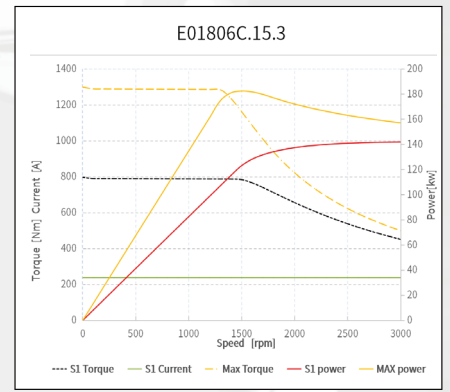
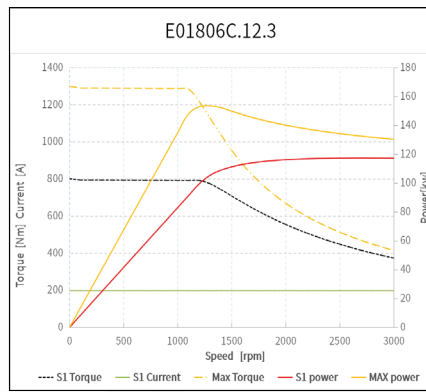
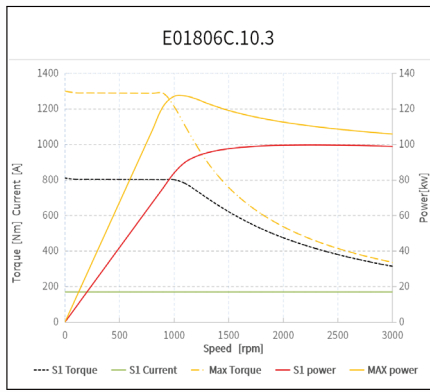

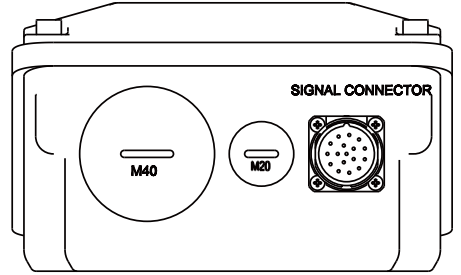
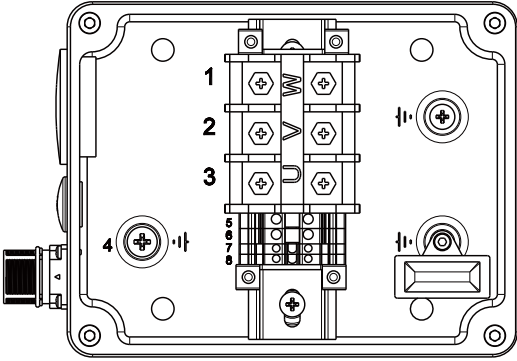

接线盒 180×142
CONNECTION BOX 180×142

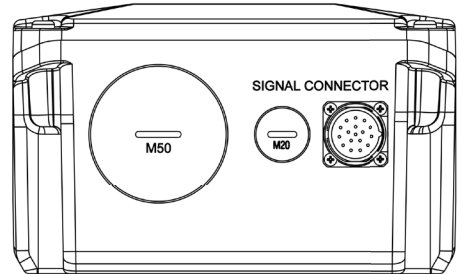
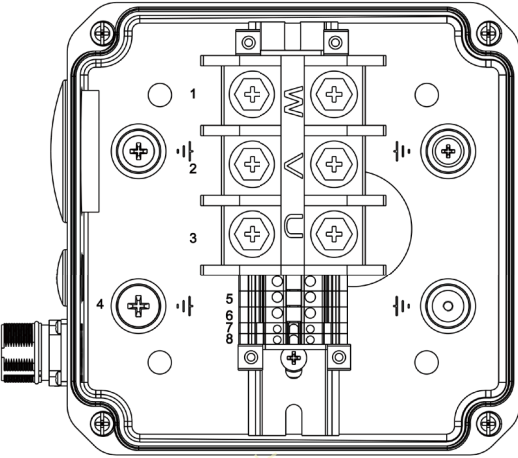

接线盒 175×175
CONNECTION BOX 175×175

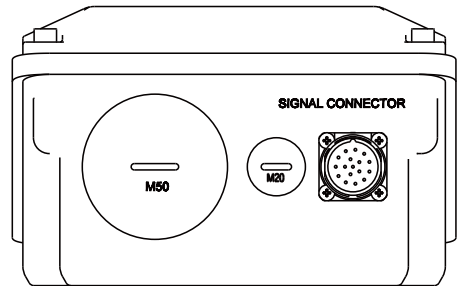
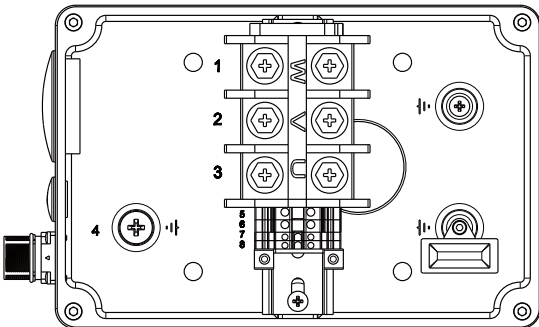

接线盒 240×160
CONNECTION BOX 240×160

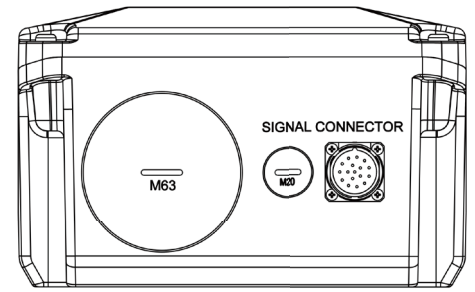
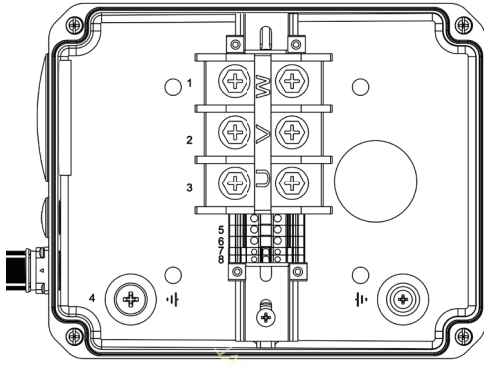

接线盒 240×195
CONNECTION BOX 240×195

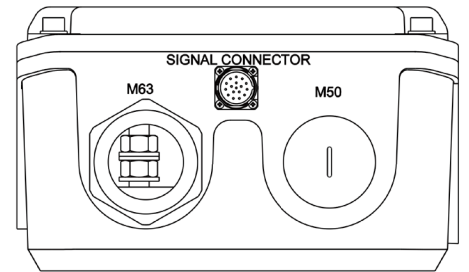
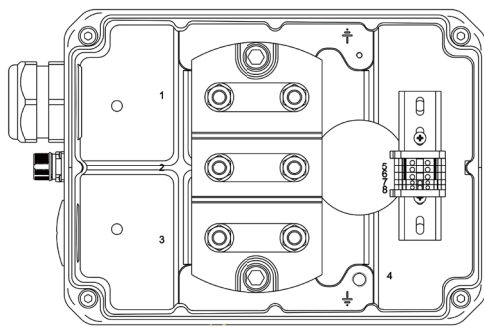

接线盒 353×264
CONNECTION BOX 353×264

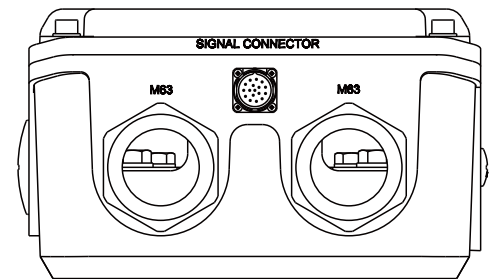
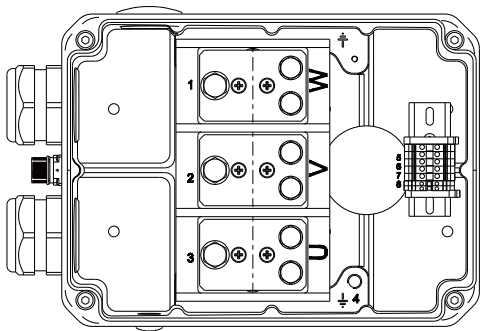

接线盒 353×264
CONNECTION BOX 353×264

接线定义 /Connection box configuration	
1	Phase W
2	Phase V
3	Phase U
4	GND
5	风扇 /Fan *
6	风扇 /Fan *

接线定义 /Connection box configuration	
7	制动器 Brake (+ 24V) *
8	制动器 Brake (0V) *
9	内部接线用 /Reserved for internal use*
10	内部接线用 /Reserved for internal use*
11	内部接线用 /Reserved for internal use*

(*) 如果存在的情况下
If present!

Motor Connections

电机接线

信号 Signal

信号插座 /Signal Connector M23-17 Pin
EnDat Type Mx, Nx

PIN	Function	AxM Port E1
1	A +	n.c.
2	A -	n.c.
3	DATA +	14
4	PTC +	8
5	CLOCK +	3
6	n.c.	n.c.
7	0 V	1
8	KTY84 +	n.c.
9	KTY84 -	n.c.
10	+ Vac	
11	B +	n.c.
12	B -	n.c.
13	DATA -	9
14	CLOCK -	4
15	0V sense	n.c.
16	Vac sense	n.c.
17	PTC -	1

信号插座 /Signal Connector M23-17 Pin
Resolver Type R

PIN	Function	AxM Port E1 PIN
1	n.c.	n.c.
2	n.c.	n.c.
3	n.c.	n.c.
4	Sin -,1 c/r	5
5	Cos +,1 c/r	3
6	Cos -,1 c/r	4
7	Resex-	10
8	KTY84 +	n.c.
9	KTY84 -	n.c.
10	Resex -	11
11	n.c.	n.c.
12	n.c.	n.c.
13	n.c.	n.c.
14	Sin +,1 c/r	2
15	n.c.	n.c.
16	PTC +	8
17	PTC -	1

信号插座 /Signal Connector M23-17 Pin
SinCos Encoder Type S1

PIN	Function	AxV Port S2 PIN	AxM Port E1 PIN
1	A +	1	7
2	A -	14	12
3	I + (index)	3	14
4	Sin -, 1 c/r	6	5
5	Cos +, 1 c/r	17	3
6	Cos -, 1 c/r	5	4
7	0 V	10	1
8	PTC +	11	8
9	PTC - / KTY -	13	1
10	+ Vcc (5Vdc)	25	6
11	B +	2	15
12	B -	15	13
13	I - (index -)	16	9
14	Sin +, 1 c/r	18	2
15	0V sense	n.c.	n.c.
16	+ Vcc sense	n.c.	n.c.
17	KTY +	n.c.	n.c.

菲仕总部 PHYSIS HEADQUARTER

宁波菲仕技术股份有限公司

Ningbo Physis Technology Co., Ltd.

浙江省宁波市北仑区小港安居路 308 号

No.308, Xiaogang Anju Road, Beilun District, Ningbo, China

总台热线 /Tel: +0086-(0)574-26922600

国内业务 Domestic Sales

销售热线 /Tel: +0086-(0)574-23459197

邮箱 /E-mail: Sales@physis.com.cn

海外业务 Overseas Sales

销售热线 /Tel: +0086-(0)574-23459168

邮箱 /E-mail: OverseaSales@physis.com.cn

售后服务 After Sales

服务热线 /Tel: +0086-(0)574-23459183

+0086-(0)574-23459182

邮箱 /E-mail: Aftersales@physis.com.cn



扫一扫了解更多

版本编号: PHESSM2603-V01

由于产品的不断更新和改进,本产品型录中的部分产品数据信息会产生变化,为了能提供更好的服务,建议您在查阅本产品型录的同时,请联系我们,以便您及时获得最新的资讯。

All technical data, drawings and product information contained here may be subject to change, in order to provide you with a continuously improved products, please contact with us for up to date information.

