

TK Series DD Servo Motors for Machine Tool

TK系列直驱力矩伺服电机--机床行业

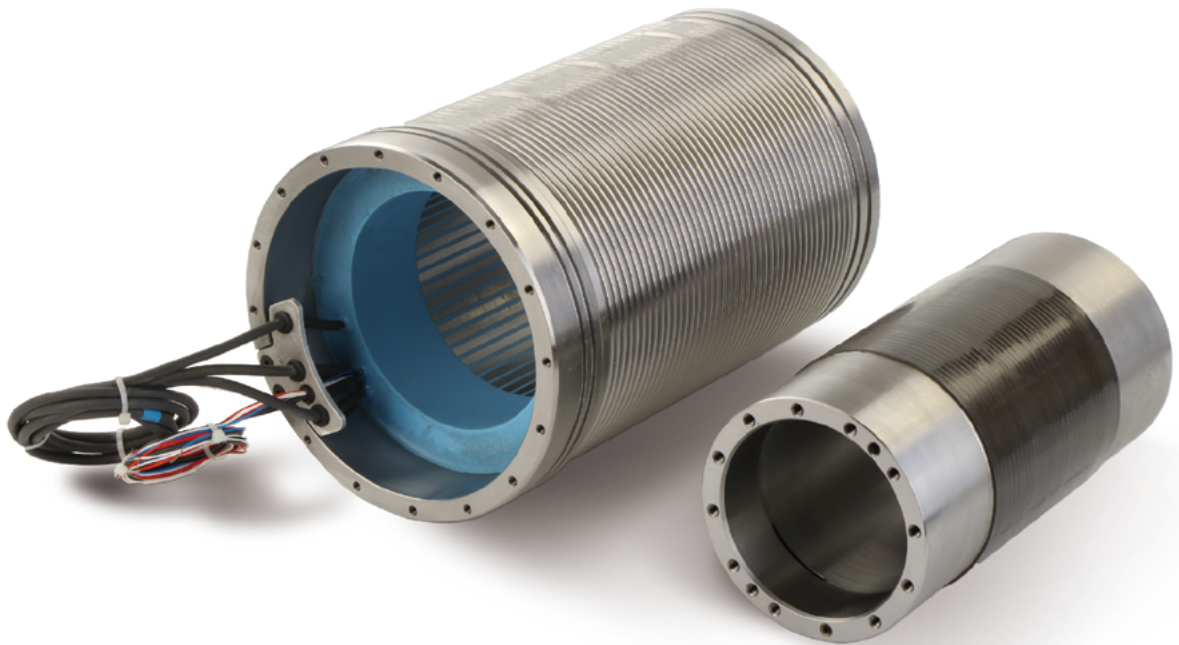

Company Profile

关于菲仕

宁波菲仕技术股份有限公司（简称：菲仕技术）成立于 2001 年，由民营控股、先进制造产业投资基金和宁波和丰创业投资有限公司等战略投资人参股，公司致力于以电驱动技术为核心的创新及产业化，为运动控制和能量转换领域提供系统产品和综合解决方案，经过多年的品牌沉淀，菲仕已成为一家集研发、生产、销售为一体，拥有国内外多家控股子公司的集团化创新型高科技企业。

Ningbo Physis Technology Co., Ltd. was founded in 2001, which is a private enterprise holding group company, invested by Advanced Manufacturing Fund and Ningbo Hefeng Venture Capital Co., Ltd. Physis always devotes to innovation and industrialization of electrical drive technology, provides servo products and solutions for the field of motion control & energy conversion. After years of brand development and accumulation, Physis became a collectivized & innovative high-tech enterprise, which collects together research and development (R&D), production and sale, has a numbers of domestic and overseas subsidiaries.



在智能制造全球化的趋势中，菲仕逐步落地国际化的战略布局，在欧洲成立了研发中心，与国内外专业科研机构、专家合作，进行定期交流和互动，以保持公司持续站立在伺服系统科技创新的最前沿，共同推进产业发展。经过多年的沉淀，顶尖人才的积累，菲仕在国内拥有省级工程技术中心、省级高新技术企业研究开发中心，并入选了国家工信部第一批专精特新“小巨人”企业！

In the globalization tendency of intelligent manufacture, Physis implements the strategic layout of the group internationalization gradually, builds the R&D center in Europe, communicate and interact regularly with the world-class scientific research institution & industry experts, which makes Physis hold on the lead of the servo system technology innovation and promote industrial development together! After years of development, accumulation of talents, Physis has provincial engineering & technology center and more than 200 people of R&D team. Until now, Physis has more than 300 patents.



3 个
研发中心

4 个
生产基地

300 +
研发团队

350 +
授权专利

产品概述 Overview

菲仕 TK 系列直驱力矩伺服电机具有高转矩密度，为高性能的运动控制场景而设计。标准无框架结构，分离式定转子，适于集成到应用设备内部。另可根据行业应用，定制专用结构，比如，金属成型行业可为整机、单轴承结构等等。

TK series direct drive servo motor provide the high torque density for high-performance motion control applications. Standard frameless structure is provided with separate stator and rotor, suitable for integration into the equipments. In addition, it can also be made with special structural design for some industries, for example, a complete machine structure, a single bearing structure for the metal forming industry, etc.

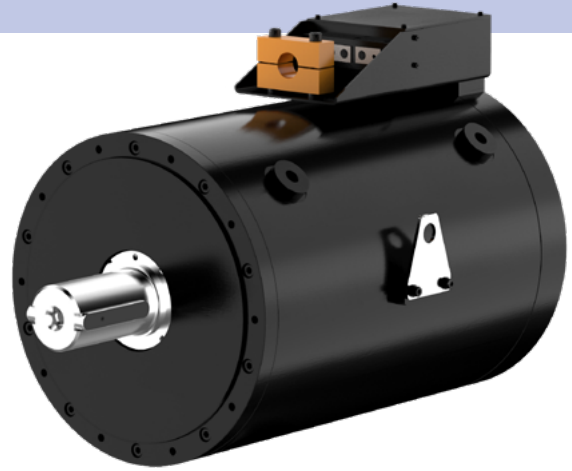

额定扭矩：5Nm ~ 20000Nm

额定转速：1rpm ~ 3500rpm

峰值功率：0.5kW ~ 900kW

冷却方式：自然冷，水冷

连接方式：散线，航插，接线盒

温度传感器：KTY84 & PTC130

Rated Torque : 5Nm ~ 20000Nm

Rated Speed : 1rpm ~ 3500rpm

Peak Power : 0.5kW ~ 900kW

Cooling : natural convection, water cooling

Connection method : power cable, plug connector, connection box

Temperature Sensor : KTY84 & PTC130

主要特点 Features

负载直连，简化传动机构，可靠性高
定转子结构紧凑，体积小，重量轻
低速运转平稳，扭矩大
直接驱动，机械传动效率高
启动扭矩大，噪音小，过载能力强
扭矩常数大，电流小，驱动器成本低
高速弱磁区大扭矩输出

Directly-connected load, simplified transmission mechanism, and higher reliability;
The stator and rotor are compact in structure, small size and light weight;
Smooth operation at low speed, with large torque;
Direct-drive, high mechanical transmission efficiency;
High starting torque, low noise, and strong overload capacity;
High torque constant, small current, and low drive cost;
High-speed field weakening area and large torque output;

适用场合 Applications

直接驱动应用
 低速大扭矩应用
 高响应高精度定位控制应用
 万转高速应用
 空间紧凑的应用

Direct-drive applications;
 Low-speed and high-torque applications;
 High-response and high-precision positioning controls applications;
 High-speed rotation application;
 Compact space applications;

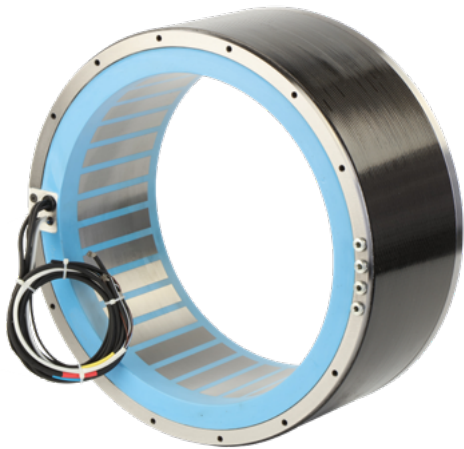

TK Series DD Servo Motors

TK085

性能参数

电机系列 Motor Serial	电机规格 Motor Type	额定扭矩 Rated Torque (Nm)	额定转速 Rated Speed (rpm)	额定功率 Rated Power (kW)	额定电流 Rated Current (A)	峰值扭矩 Max Torque (Nm)	峰值电流 Max Current (A)	最高转速 Max Speed (rpm)	扭矩常数 Kt (Nm/A)
TK085	TK085-050-005C	6	10000	6.3	12	24	53	15000	0.57
	TK085C-100-004C	9	11000	10.5	27	40	158	35000	0.34

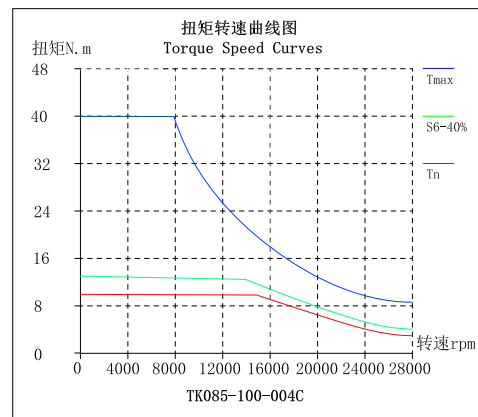
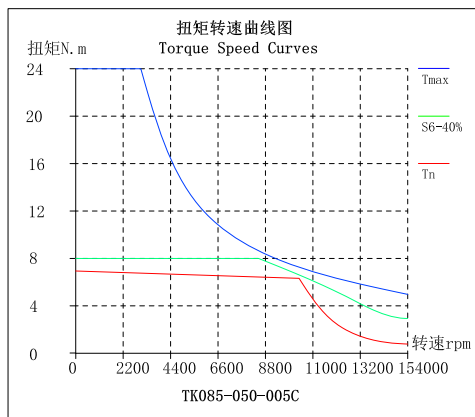

尺寸参数

电机系列 Motor Serial	电机规格 Motor Type	DS1	DS2	DS3	DR1	DR2	L	LS1	LR1	AS1	AR1
TK085	TK085-050-005C	102	102	58.4	57.2	35	24	103	64	8-M4 on Φ 91	6-M4 on Φ 43
	TK085C-100-004C	102	102	58.4	57.2	37.8	21	155	118	8-M4 on Φ 91	6-M4 on Φ 43

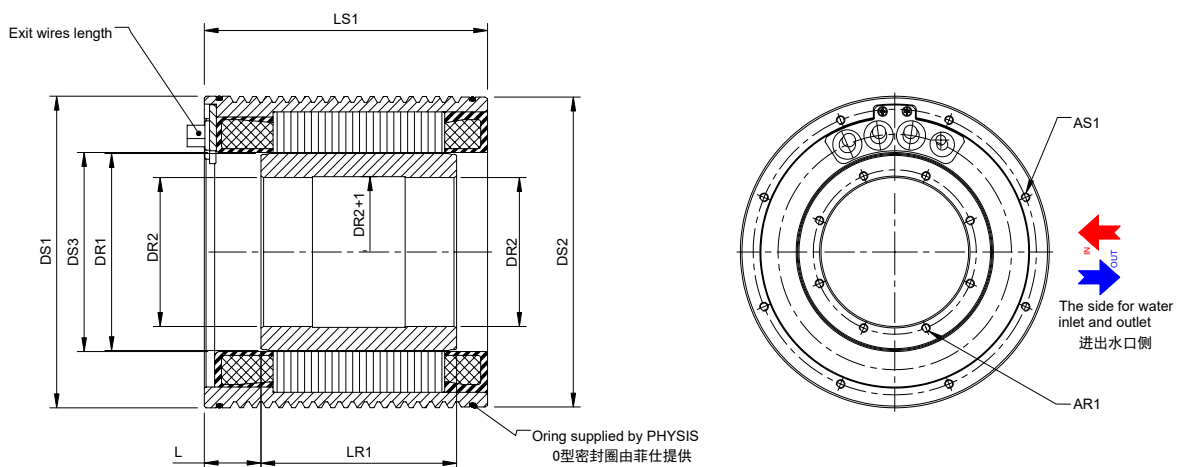

TK110

性能参数

电机系列 Motor Serial	电机规格 Motor Type	额定扭矩 Rated Torque (Nm)	额定转速 Rated Speed (rpm)	额定功率 Rated Power (kW)	额定电流 Rated Current (A)	峰值扭矩 Max Torque (Nm)	峰值电流 Max Current (A)	最高转速 Max Speed (rpm)	扭矩常数 Kt (Nm/A)
TK110	TK110-060-009C	15	4500	7.1	19.7	40	60	10000	0.85
	TK110-090-009C	21	3200	7	27.1	60	87	12000	0.855
	TK110I-120-007C	25	5500	14.4	34	53	91	18000	0.74

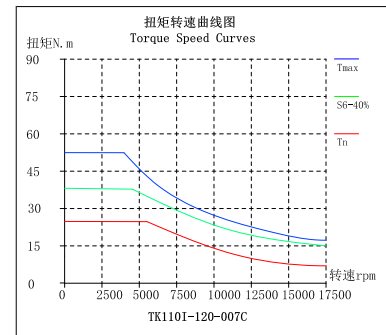
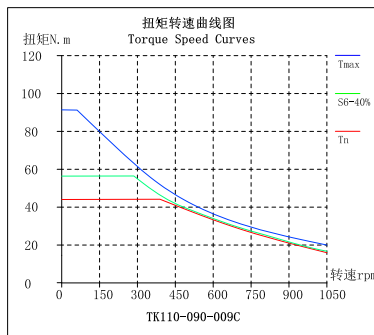
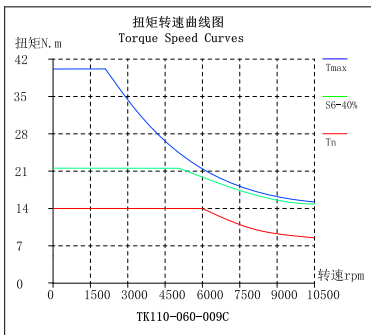

尺寸参数

电机系列 Motor Serial	电机规格 Motor Type	DS1	DS2	DS3	DR1	DR2	L	LS1	LR1	AS1	AR1
TK110	TK110-060-009C	120	119	68.5	66.5	50	28.5	119	73	8-M4 on Φ 110	8-M4 on Φ 55
	TK110-090-009C	120	120	68.5	66.5	50	33.5	160	103	8-M4 on Φ 110	8-M4 on Φ 55
	TK110I-120-007C	120	120	68.5	67.7	46	22	175	127.5	8-M4 on Φ 110	8-M4 on Φ 55

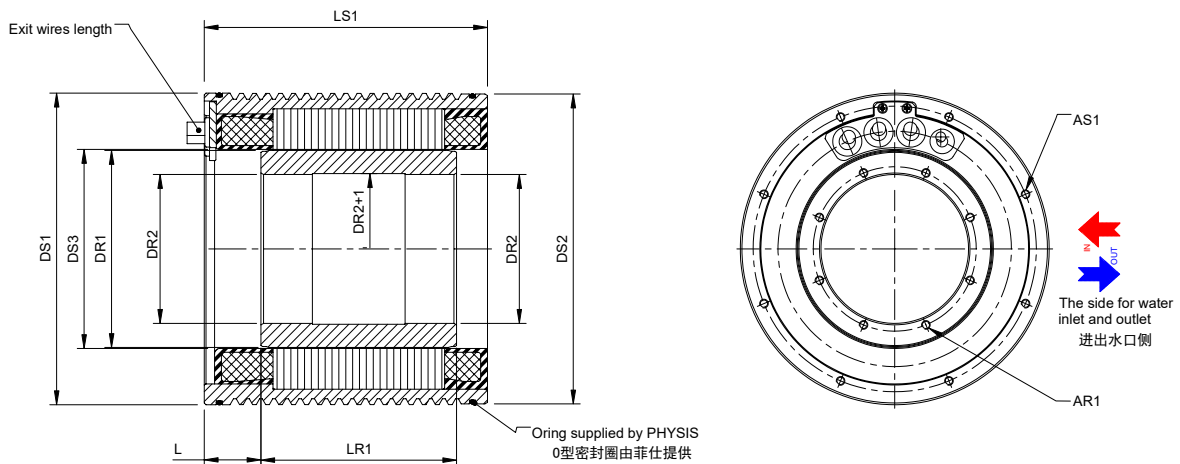

TK Series DD Servo Motors

TK120

性能参数

电机系列 Motor Serial	电机规格 Motor Type	额定扭矩 Rated Torque (Nm)	额定转速 Rated Speed (rpm)	额定功率 Rated Power (kW)	额定电流 Rated Current (A)	峰值扭矩 Max Torque (Nm)	峰值电流 Max Current (A)	最高转速 Max Speed (rpm)	扭矩常数 Kt (Nm/A)
TK120	TK120I-075-013C	13	4500	6.1	11	68	66	10000	1.34
	TK120I-150-008C	30	5000	15.7	36.6	137	205	15000	0.84
	TK120I-170-055C	25	8000	20.9	49.5	100	230	24000	0.55

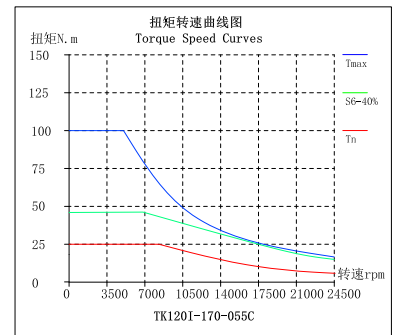
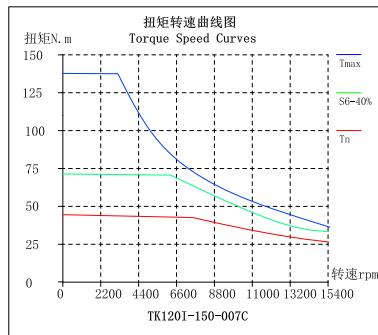
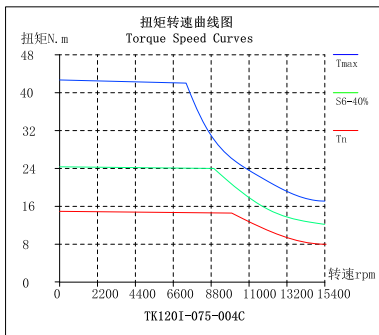

尺寸参数

电机系列 Motor Serial	电机规格 Motor Type	DS1	DS2	DS3	DR1	DR2	L	LS1	LR1	AS1	AR1
TK120	TK120I-075-013C	135	135	80.5	78.9	53	30	135	100	8-M4 on Φ 128	8-M4 on Φ 65
	TK120I-150-008C	135	135	80.5	78.9	53	34	210	175	8-M4 on Φ 128	8-M4 on Φ 65
	TK120I-170-055C	135	135	80.5	78.9	53	34	230	195	8-M4 on Φ 128	8-M4 on Φ 5

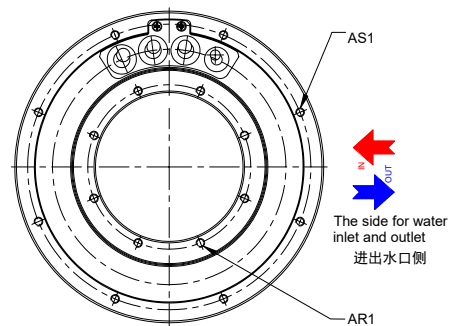
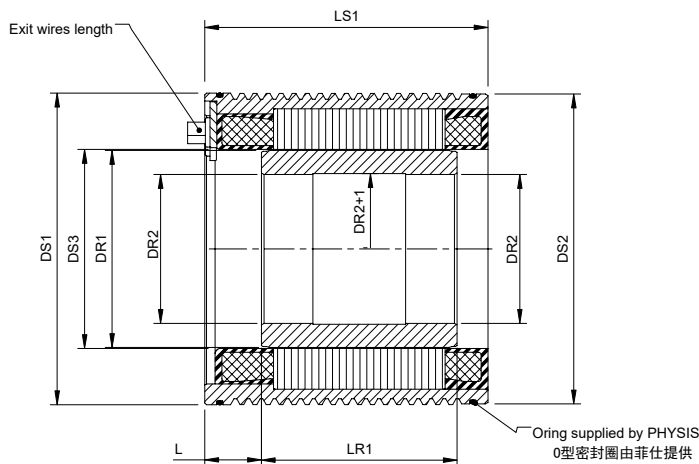

TK142

性能参数

电机系列 Motor Serial	电机规格 Motor Type	额定扭矩 Rated Torque (Nm)	额定转速 Rated Speed (rpm)	额定功率 Rated Power (kW)	额定电流 Rated Current (A)	峰值扭矩 Max Torque (Nm)	峰值电流 Max Current (A)	最高转速 Max Speed (rpm)	扭矩常数 Kt (Nm/A)
TK142	TK142-060-013C	28	3500	10.3	25	74	76	10000	1.28
	TK142-080-026C	50	1600	8.4	18.7	102	48	5000	2.68
	TK142-160-012C	45	3000	14.1	44	123	133	6000	1.23

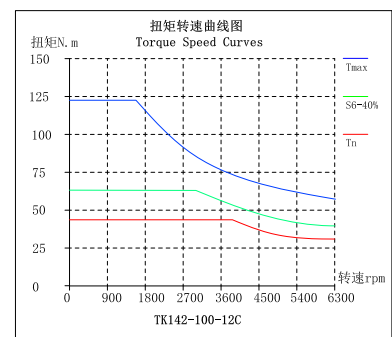
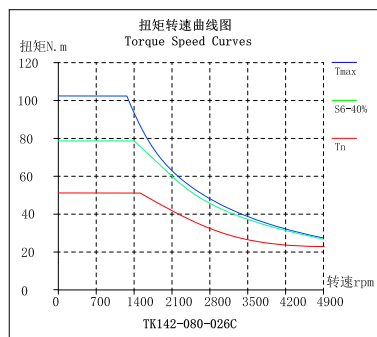
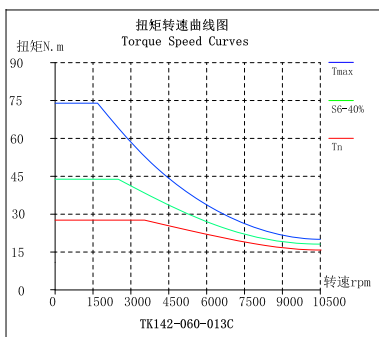

尺寸参数

电机系列 Motor Serial	电机规格 Motor Type	DS1	DS2	DS3	DR1	DR2	L	LS1	LR1	AS1	AR1
TK142	TK142-060-013C	155	154	95	94	70	20	110	76	8-M5 on Φ 143	6-M4 on Φ 78
	TK142-080-026C	155	154	95	94	70	14	130	110	8-M5 on Φ 143	6-M4 on Φ 78
	TK142-160-012C	155	154	95	94	70	27.5	152	135	8-M5 on Φ 143	6-M4 on Φ 78

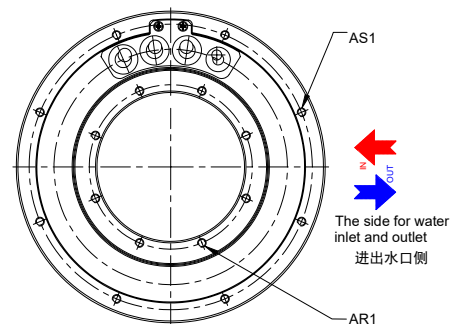
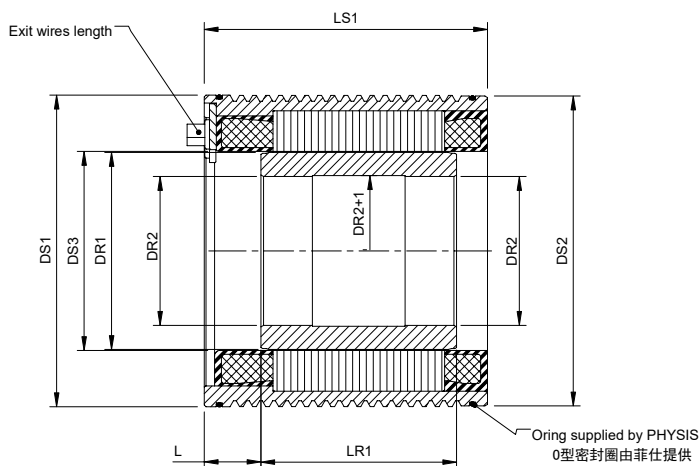

TK Series DD Servo Motors

TK146I

性能参数

电机系列 Motor Serial	电机规格 Motor Type	额定扭矩 Rated Torque (Nm)	额定转速 Rated Speed (rpm)	额定功率 Rated Power (kW)	额定电流 Rated Current (A)	峰值扭矩 Max Torque (Nm)	峰值电流 Max Current (A)	最高转速 Max Speed (rpm)	扭矩常数 Kt (Nm/A)
TK146I	TK146I-120-008C	52	6000	32.7	70	130	200	20000	0.67

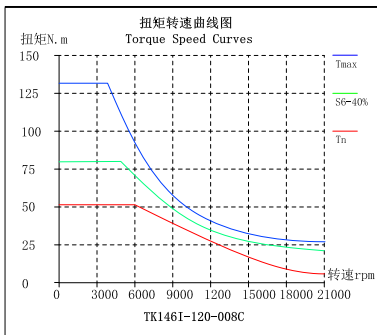

尺寸参数

电机系列 Motor Serial	电机规格 Motor Type	DS1	DS2	DS3	DR1	DR2	L	LS1	LR1	AS1	AR1
TK146I	TK146I-120-008C	161	160	95	93.4	55.2	42.5	205	140	8-M5 on $\Phi 149$	6-M4 on $\Phi 61$

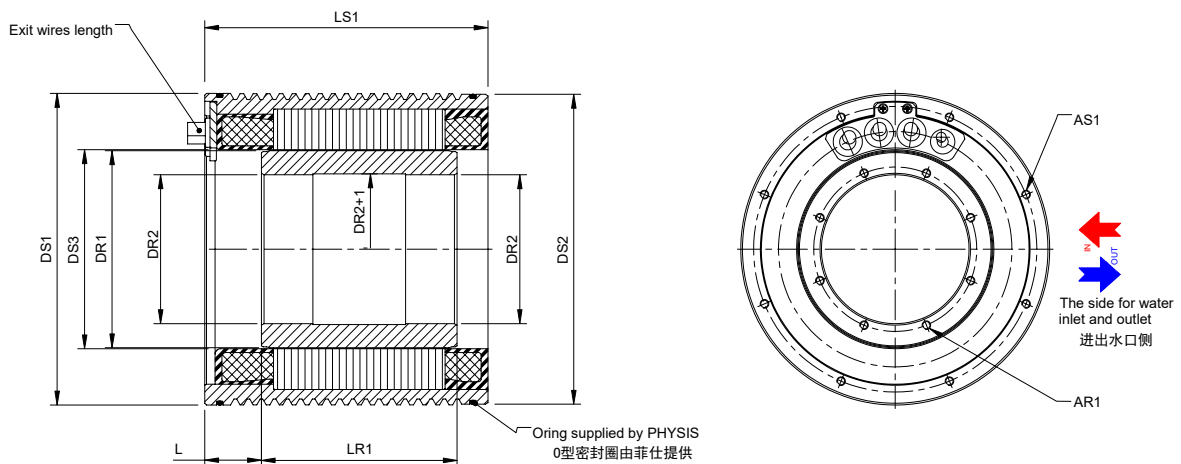

TK164

性能参数

电机系列 Motor Serial	电机规格 Motor Type	额定扭矩 Rated Torque (Nm)	额定转速 Rated Speed (rpm)	额定功率 Rated Power (kW)	额定电流 Rated Current (A)	峰值扭矩 Max Torque (Nm)	峰值电流 Max Current (A)	最高转速 Max Speed (rpm)	扭矩常数 Kt (Nm/A)
TK164	TK164-045-016C	22	3700	8.5	18.2	84	65	6000	1.59
	TK164-070-017C	39	3600	14.7	24.9	130	93	6000	1.65
	TK164-100-028C	74	1700	13.2	29.1	177	80	5000	2.83
	TK164-140-025C	90	1700	16	40	262	133	5000	2.47

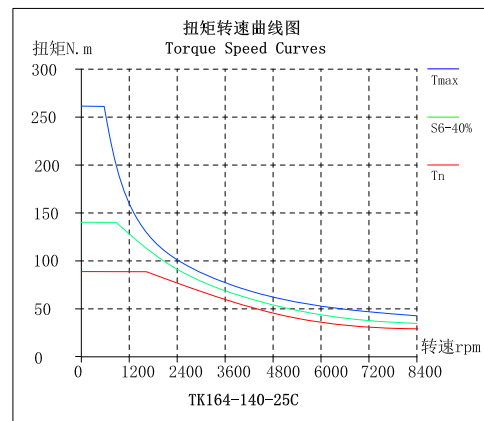
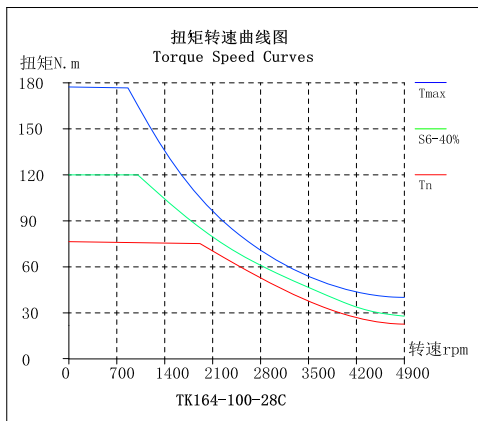
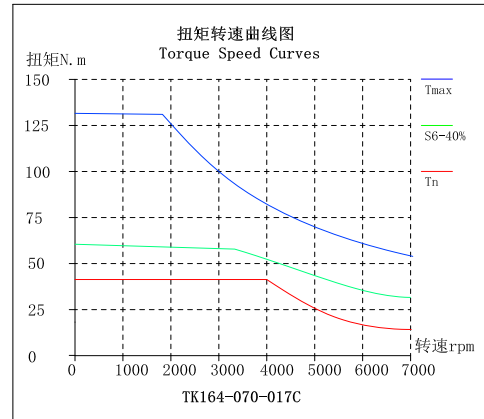
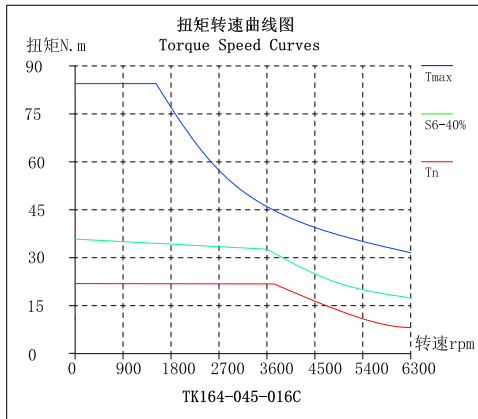

尺寸参数

电机系列 Motor Serial	电机规格 Motor Type	DS1	DS2	DS3	DR1	DR2	L	LS1	LR1	AS1	AR1
TK164	TK164-045-016C	180	179	115	113.8	86	26	102	59	8-M5 on $\Phi 165$	8-M5 on $\Phi 95$
	TK164-070-017C	180	179	115	113.8	86	26	127	84	8-M5 on $\Phi 165$	8-M5 on $\Phi 95$
	TK164-100-028C	180	179	115	113.8	86	29.5	171	118	8-M5 on $\Phi 165$	8-M5 on $\Phi 95$
	TK164-140-025C	180	179	115	113.8	86	23	195	154	8-M5 on $\Phi 165$	8-M5 on $\Phi 95$

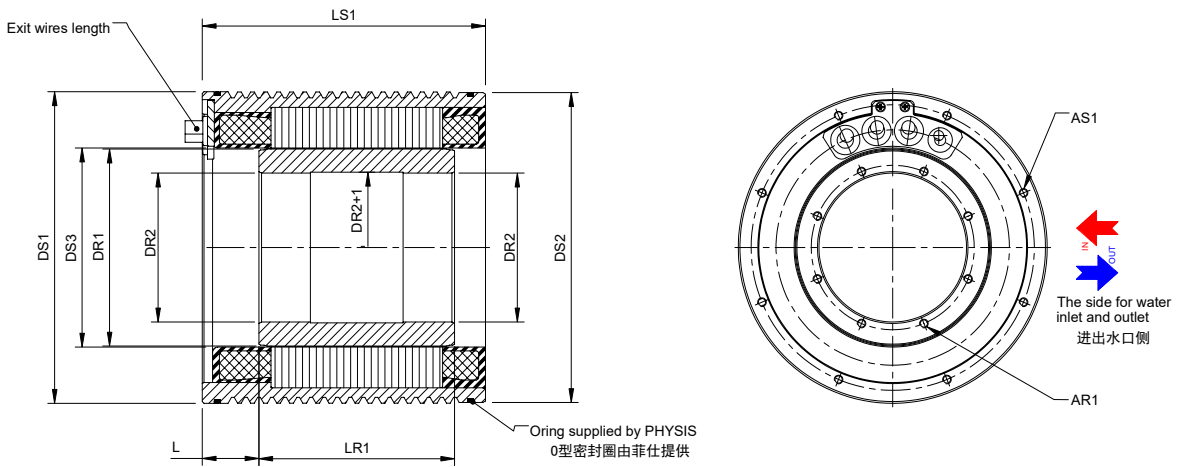

TK172

性能参数

电机系列 Motor Serial	电机规格 Motor Type	额定扭矩 Rated Torque (Nm)	额定转速 Rated Speed (rpm)	额定功率 Rated Power (kW)	额定电流 Rated Current (A)	峰值扭矩 Max Torque (Nm)	峰值电流 Max Current (A)	最高转速 Max Speed (rpm)	扭矩常数 Kt (Nm/A)
TK172	TK172-180-011C	99	4700	48.6	104	214	321	18000	1.1
	TK172-240-014C	132	3000	41.5	104	282	321	20000	1.4

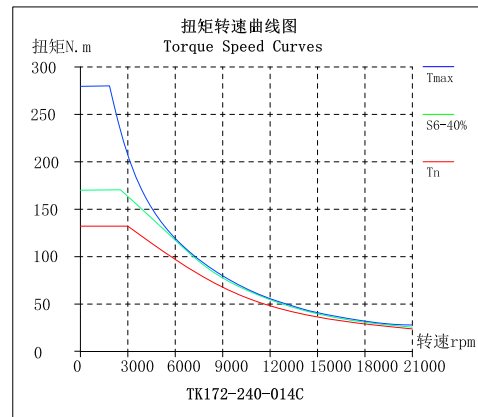
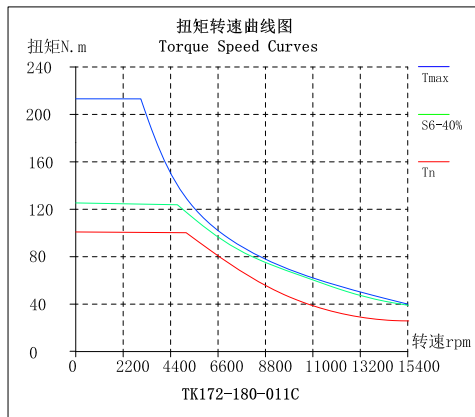

尺寸参数

电机系列 Motor Serial	电机规格 Motor Type	DS1	DS2	DS3	DR1	DR2	L	LS1	LR1	AS1	AR1
TK172	TK172-180-011C	190	189	115	113.4	86	38	260	196	10-M5 on Φ 94	10-M6 on Φ 175
	TK172-240-014C	190	189	115	113.4	90	33	335	270	10-M5 on Φ 94	10-M6 on Φ 175

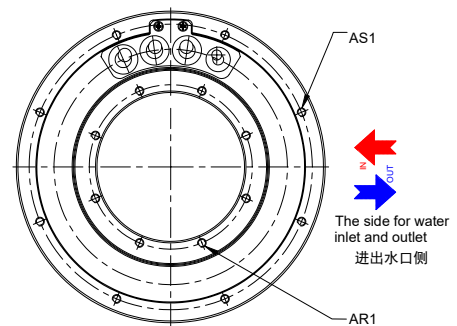
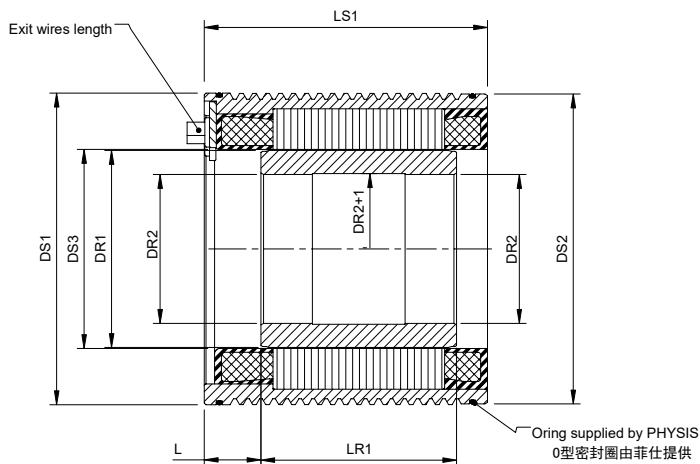

TK Series DD Servo Motors

TK220

性能参数

电机系列 Motor Serial	电机规格 Motor Type	额定扭矩 Rated Torque (Nm)	额定转速 Rated Speed (rpm)	额定功率 Rated Power (kW)	额定电流 Rated Current (A)	峰值扭矩 Max Torque (Nm)	峰值电流 Max Current (A)	最高转速 Max Speed (rpm)	扭矩常数 Kt (Nm/A)
TK220	TK220-050-023C	56	2000	11.7	26.8	159	81	5000	2.32
	TK220-085-027C	110	1500	17.2	44.5	270	118	5500	2.73
	TK220-090-089C	100	650	6.8	46	289	105	4000	3.4

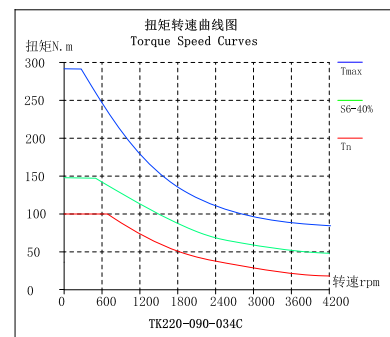
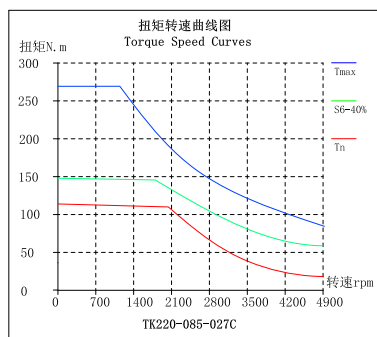
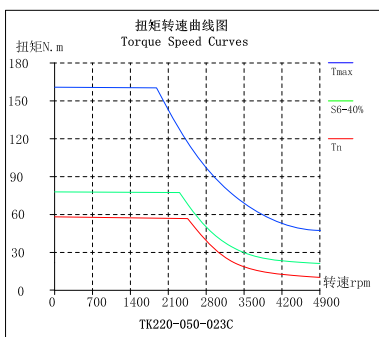

尺寸参数

电机系列 Motor Serial	电机规格 Motor Type	DS1	DS2	DS3	DR1	DR2	L	LS1	LR1	AS1	AR1
TK220	TK220-050-023C	245	244	150	148.8	110	34.5	130	65	8-M5 on Φ 229	8-M6 on Φ 125
	TK220-085-027CX10	245	244	150	148.8	110	36.5	168	102	8-M5 on Φ 229	8-M6 on Φ 125
	TK220-090-089C	245	244	150	148.8	110	39	168	102	8-M5 on Φ 229	8-M6 on Φ 125

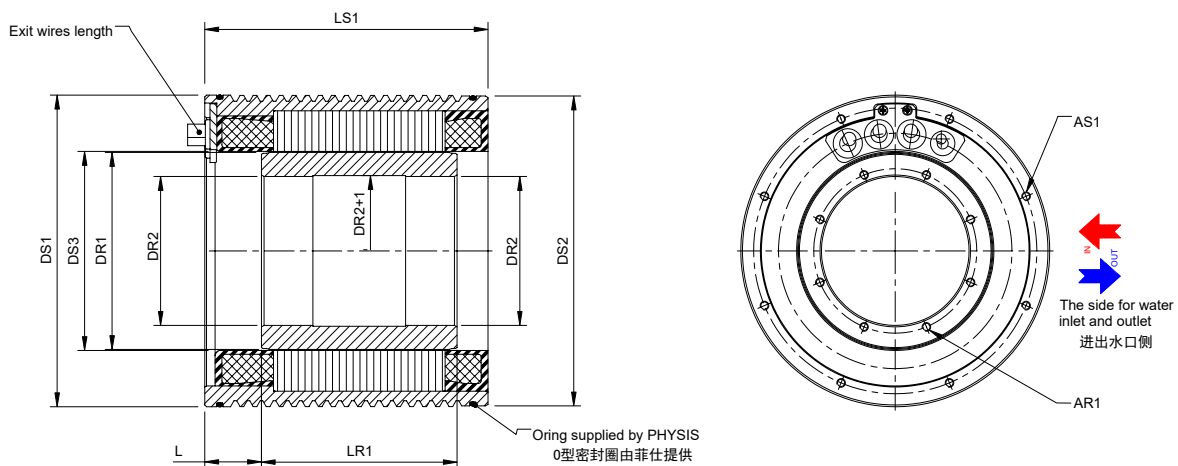

TK240

性能参数

电机系列 Motor Serial	电机规格 Motor Type	额定扭矩 Rated Torque (Nm)	额定转速 Rated Speed (rpm)	额定功率 Rated Power (kW)	额定电流 Rated Current (A)	峰值扭矩 Max Torque (Nm)	峰值电流 Max Current (A)	最高转速 Max Speed (rpm)	扭矩常数 Kt (Nm/A)
TK240	TK240-140-04C	220	1150	26.5	63.2	606	199	4000	3.9
	TK240-160-037C	320	1100	36.9	95	693	234	4000	3.7
	TK240-200-043C	410	1000	42.9	112	914	283	4000	4.3

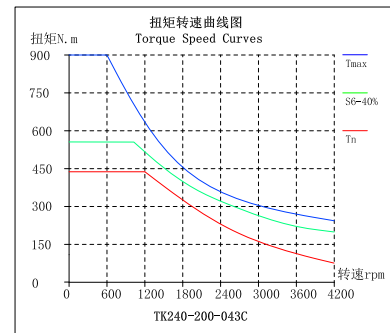
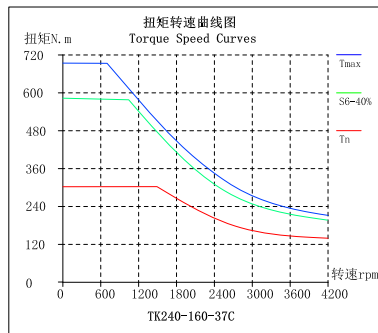
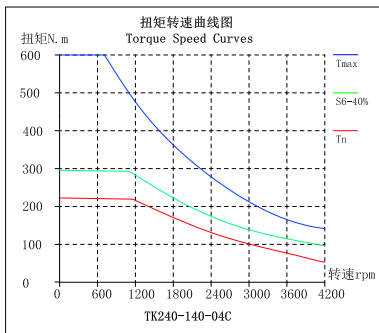

尺寸参数

电机系列 Motor Serial	电机规格 Motor Type	DS1	DS2	DS3	DR1	DR2	L	LS1	LR1	AS1	AR1
TK240	TK240-140-04C	256	255	175	173.4	140	26	215	164	8-M5 on Φ247	8-M6 on Φ152
	TK240-160-037C	256	255	175	173.4	140	31	235	185	8-M5 on Φ247	8-M6 on Φ152
	TK240-200-043C	256	255	175	173.4	140	36	279	216	8-M6 on Φ247	8-M6 on Φ152

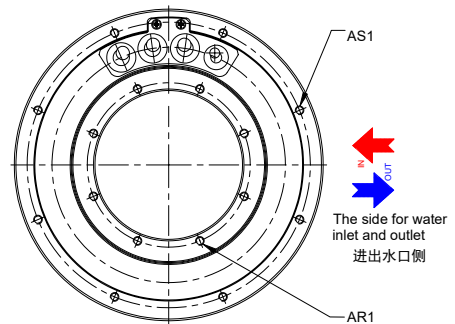
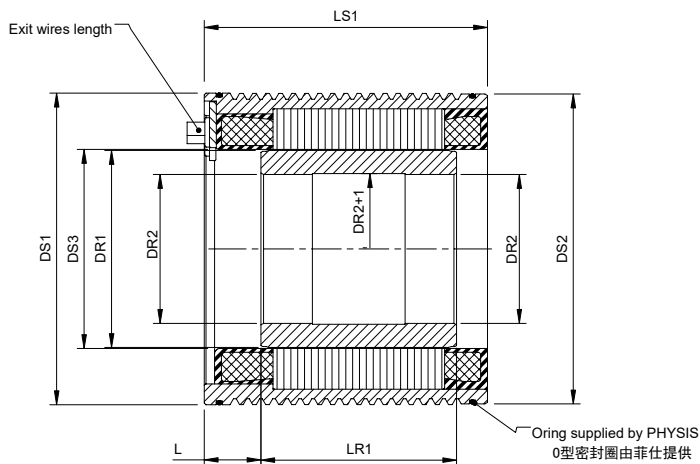

TK Series DD Servo Motors

TK270

性能参数

电机系列 Motor Serial	电机规格 Motor Type	额定扭矩 Rated Torque (Nm)	额定转速 Rated Speed (rpm)	额定功率 Rated Power (kW)	额定电流 Rated Current (A)	峰值扭矩 Max Torque (Nm)	峰值电流 Max Current (A)	最高转速 Max Speed (rpm)	扭矩常数 Kt (Nm/A)
TK270	TK270-220-063C	570	700	41.8	100.4	1046	240	3000	6.3

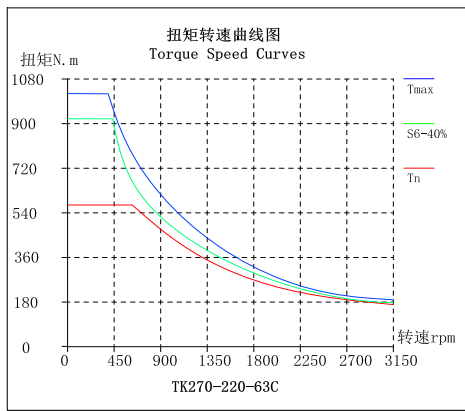

尺寸参数

电机系列 Motor Serial	电机规格 Motor Type	DS1	DS2	DS3	DR1	DR2	L	LS1	LR1	AS1	AR1
TK270	TK270-220-063C	288	287	200	198	160	43	300	234	12-M6 on Φ 272	12-M6 on Φ 178

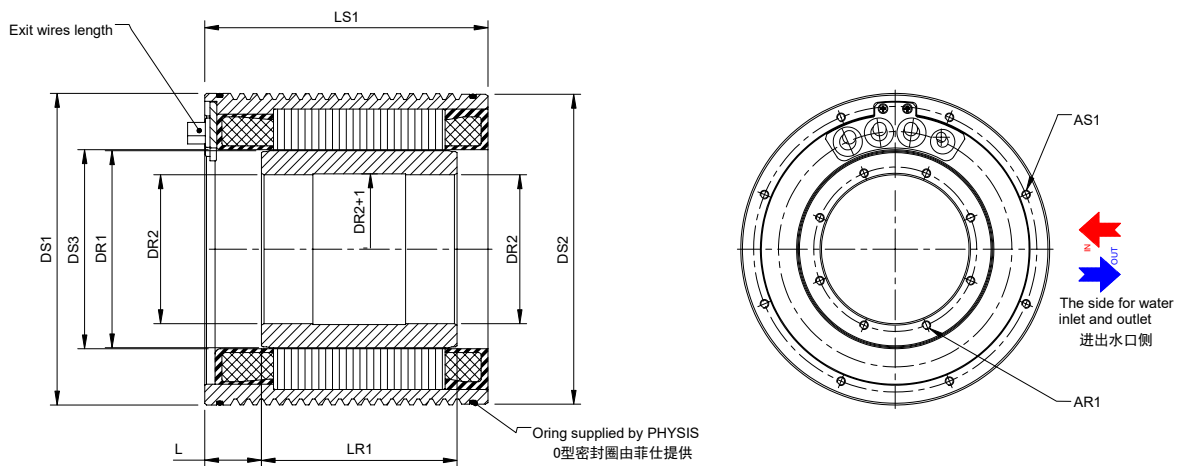

TK310

性能参数

电机系列 Motor Serial	电机规格 Motor Type	额定扭矩 Rated Torque (Nm)	额定转速 Rated Speed (rpm)	额定功率 Rated Power (kW)	额定电流 Rated Current (A)	峰值扭矩 Max Torque (Nm)	峰值电流 Max Current (A)	最高转速 Max Speed (rpm)	扭矩常数 Kt (Nm/A)
TK310	TK310-035-015C	124	100	1.3	9.8	242	22	460	14.6
	TK310-050-024C	231	100	2.4	10.9	374	20	279	23.9
	TK310-070-015C	279	100	2.9	20.7	480	39	400	15.6
	TK310-090-015C	340	120	4.3	26.8	623	55	250	15.3
	TK310-120-035C	450	100	4.7	14	897	34	200	35
	TK310-160-045C	650	70	4.8	16	1064	28	140	45

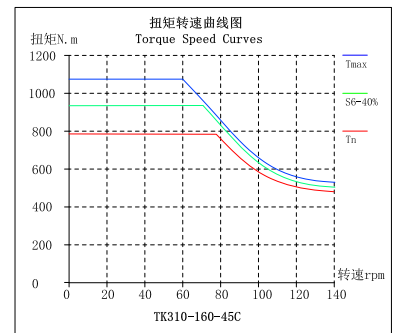
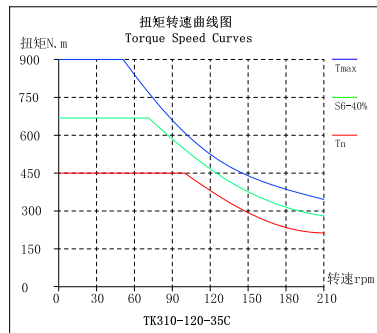
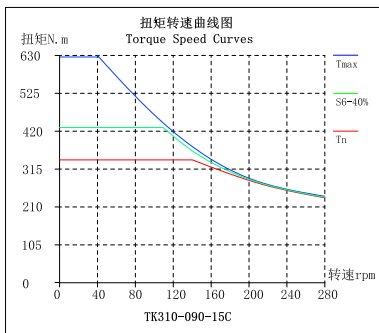
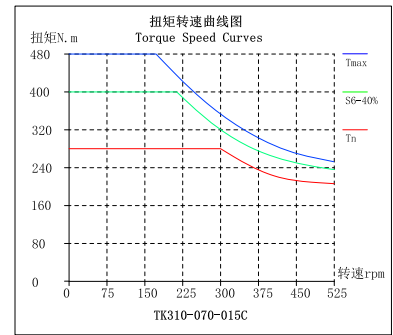
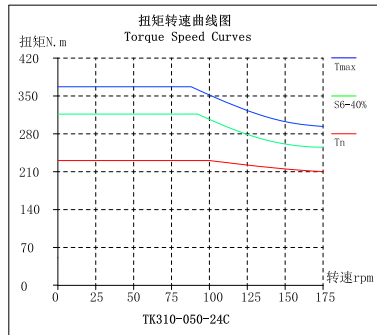
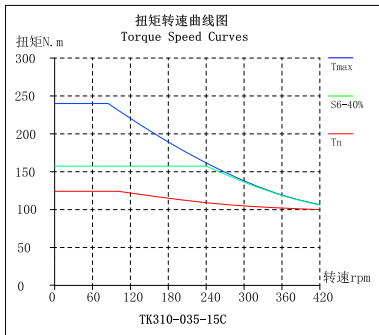

尺寸参数

电机系列 Motor Serial	电机规格 Motor Type	DS1	DS2	DS3	DR1	DR2	L	LS1	LR1	AS1	AR1
TK310	TK310-035-015C	310	309	230	228.6	199	21.5	89	52	12-M5 on $\Phi 296$	12-M5 on $\Phi 210$
	TK310-050-024C	310	310	230	228.6	200	18	110	78	12-M6 on $\Phi 300$	12-M5 on $\Phi 210$
	TK310-070-015C	310	310	230	228.6	200	20.5	130	90	12-M5 on $\Phi 300$	12-M5 on $\Phi 210$
	TK310-090-015C	310	310	230	228.6	200	21	149	110	12-M5 on $\Phi 300$	12-M5 on $\Phi 210$
	TK310-120-035C	310	309	230	228.6	200	19	170	138	12-M5 on $\Phi 300$	12-M5 on $\Phi 210$
	TK310-160-045C	310	309	230.4	229.2	200	21.5	190	177	12-M4 on $\Phi 296$	12-M5 on $\Phi 208$

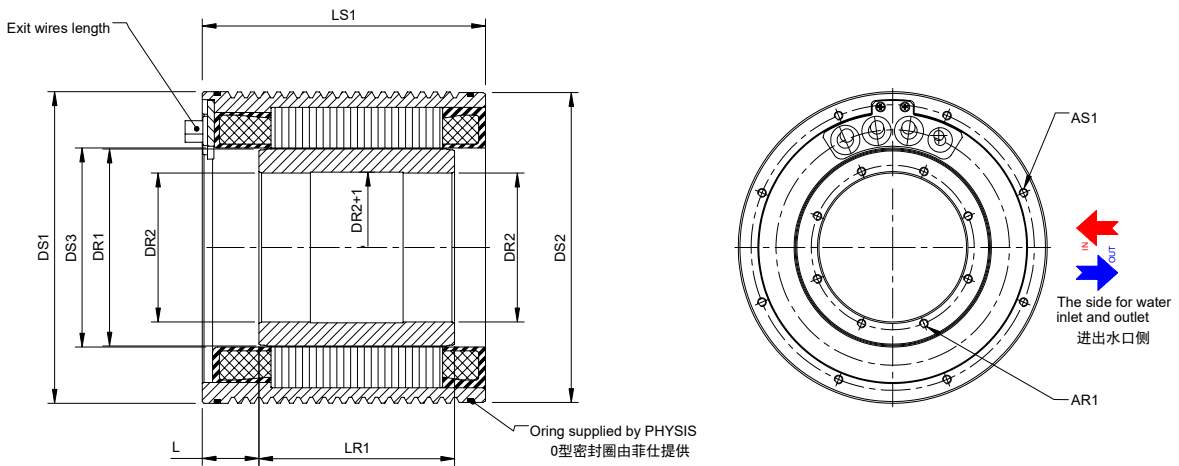

TK370

性能参数

电机系列 Motor Serial	电机规格 Motor Type	额定扭矩 Rated Torque (Nm)	额定转速 Rated Speed (rpm)	额定功率 Rated Power (kW)	额定电流 Rated Current (A)	峰值扭矩 Max Torque (Nm)	峰值电流 Max Current (A)	最高转速 Max Speed (rpm)	扭矩常数 Kt (Nm/A)
TK370	TK370-100-30C	570	100	6	21	1272	54	210	29.6
	TK370-140-20C	890	210	19.5	50	1880	125	400	20
	TK370-170-30C	1200	100	12.6	45.3	2122	76	430	31.2

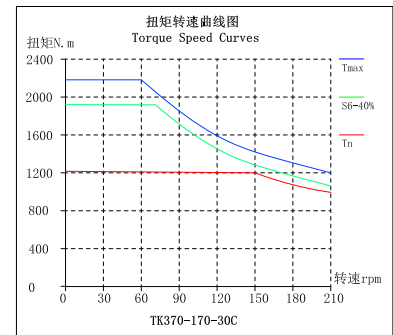
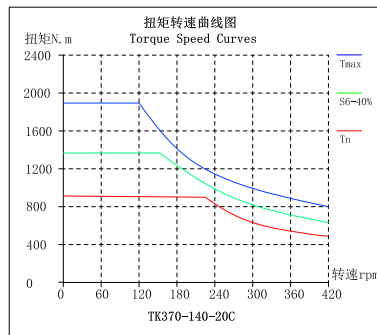
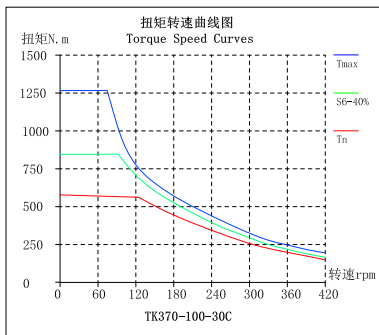

尺寸参数

电机系列 Motor Serial	电机规格 Motor Type	DS1	DS2	DS3	DR1	DR2	L	LS1	LR1	AS1	AR1
TK370	TK370-100-30C	390	390	300	298.4	265.6	24.5	162	120	16-M6 on Φ 373.5	18-M6 on Φ 275
	TK370-140-20C	390	390	300	298.4	265.6	20	210	190	16-M6 on Φ 373.5	18-M6 on Φ 275
	TK370-170-30C	390	390	300	298.4	265	29.5	245	195	24-M6 on Φ 373.5	24-M6 on Φ 277

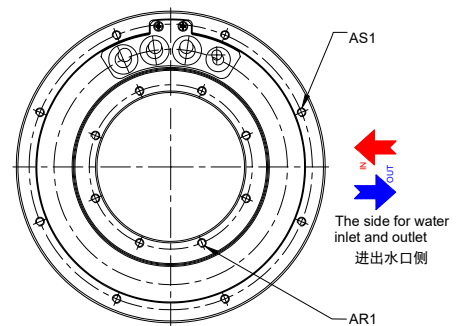
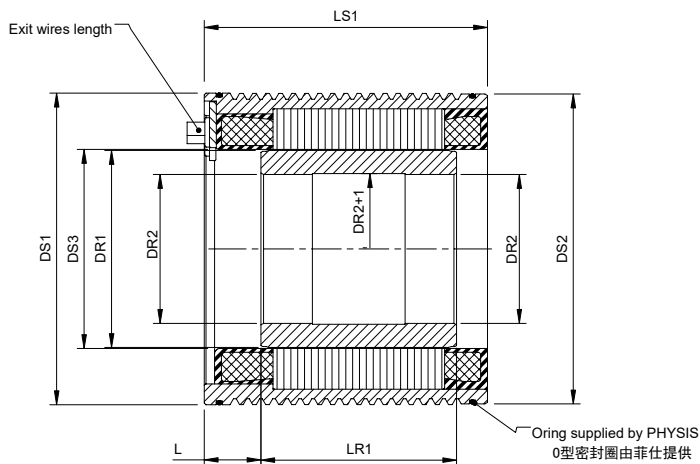

TK Series DD Servo Motors

TK440

性能参数

电机系列 Motor Serial	电机规格 Motor Type	额定扭矩 Rated Torque (Nm)	额定转速 Rated Speed (rpm)	额定功率 Rated Power (kW)	额定电流 Rated Current (A)	峰值扭矩 Max Torque (Nm)	峰值电流 Max Current (A)	最高转速 Max Speed (rpm)	扭矩常数 Kt (Nm/A)
TK440	TK440-50-40C	440	100	4.6	12.1	858	26	200	40.5
	TK440-130-80C	1260	45	5.9	17.8	2200	28	60	79

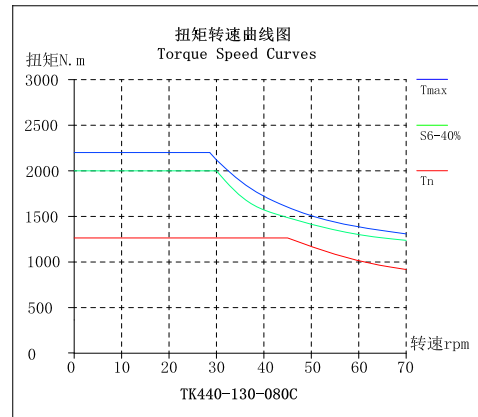
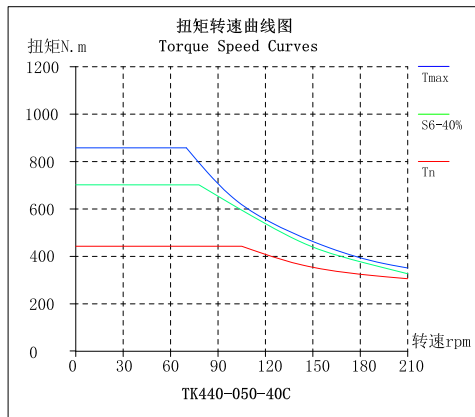

尺寸参数

电机系列 Motor Serial	电机规格 Motor Type	DS1	DS2	DS3	DR1	DR2	L	LS1	LR1	AS1	AR1
TK440	TK440-50-40C	450	450	348.4	346.4	300	15	101	75	20-M6 on Φ 423	20-M6 on Φ 315
	TK440-130-80C	450	450	348.4	346.4	285	21	161	183	20-M6 on Φ 427	20-M6 on Φ 296

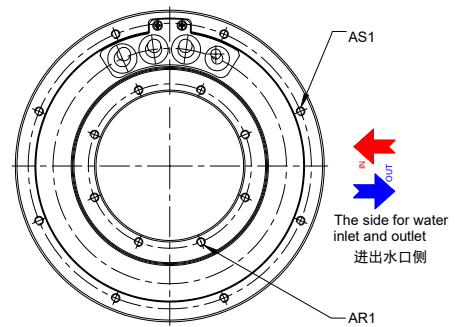
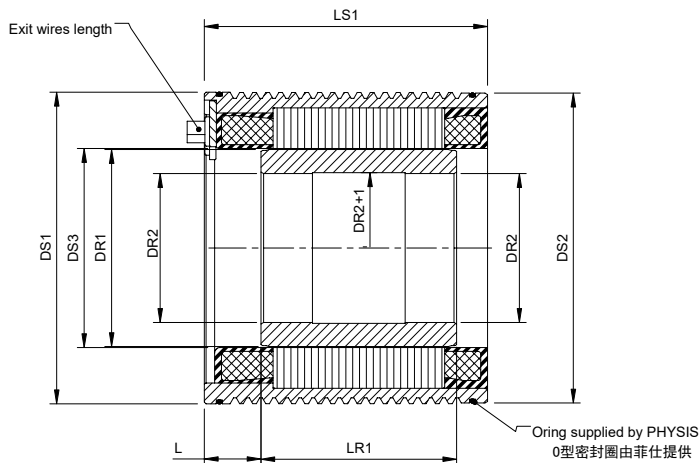

TK450

性能参数

电机系列 Motor Serial	电机规格 Motor Type	额定扭矩 Rated Torque (Nm)	额定转速 Rated Speed (rpm)	额定功率 Rated Power (kW)	额定电流 Rated Current (A)	峰值扭矩 Max Torque (Nm)	峰值电流 Max Current (A)	最高转速 Max Speed (rpm)	扭矩常数 Kt (Nm/A)
TK450	TK450-140-054C	1321	70	9.7	27	2575	53	125	54.2
	TK450-330-027C	3500	190	69.6	150	6718	329	230	27

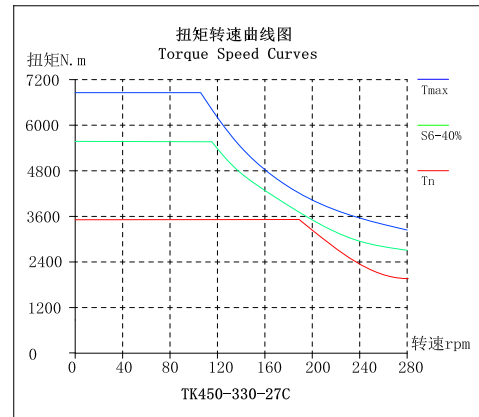
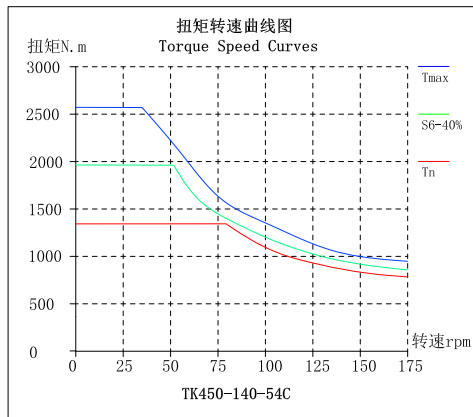

尺寸参数

电机系列 Motor Serial	电机规格 Motor Type	DS1	DS2	DS3	DR1	DR2	L	LS1	LR1	AS1	AR1
TK450	TK450-140-054C	470	469	360	357.6	320	43	230	154	24-M6 on $\Phi 450$	12-M6 on $\Phi 332$
	TK450-330-027C	470	469	360	357.6	320	32	460	350	24-M6 on $\Phi 450$	12-M6 on $\Phi 332$

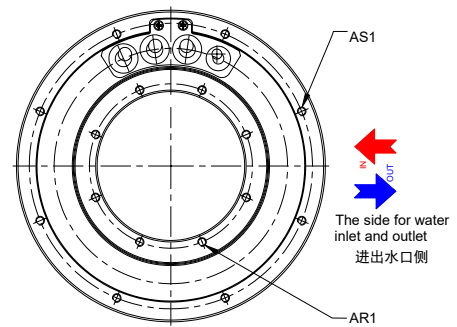
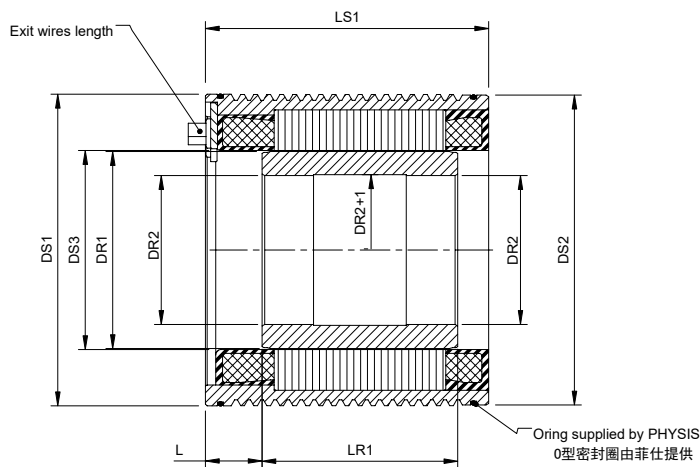

TK Series DD Servo Motors

TK540

性能参数

电机系列 Motor Serial	电机规格 Motor Type	额定扭矩 Rated Torque (Nm)	额定转速 Rated Speed (rpm)	额定功率 Rated Power (kW)	额定电流 Rated Current (A)	峰值扭矩 Max Torque (Nm)	峰值电流 Max Current (A)	最高转速 Max Speed (rpm)	扭矩常数 Kt (Nm/A)
TK540	TK540-140-44C	2020	100	21.2	51	4008	109	150	44.4
	TK540-190-23C	2604	210	57.3	130	5439	287	290	23
	TK540-220-42C	3500	100	36.7	93	6290	191	200	42.9

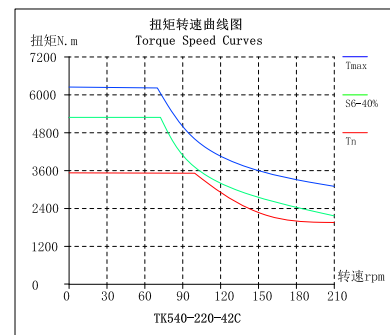
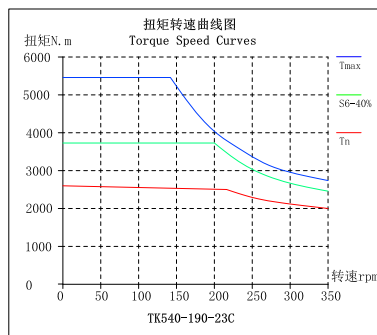
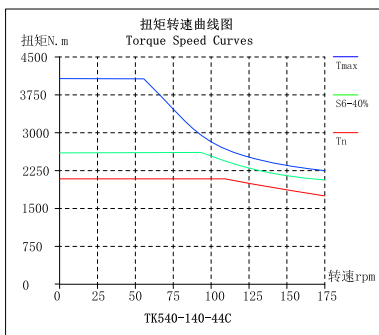

尺寸参数

电机系列 Motor Serial	电机规格 Motor Type	DS1	DS2	DS3	DR1	DR2	L	LS1	LR1	AS1	AR1
TK540	TK540-140-44C	570	570	450	447.6	406	40	230	160	24-M8 on $\Phi 550$	24-M8 on $\Phi 420$
	TK540-190-23C	570	570	450	447.6	406	40	280	210	24-M8 on $\Phi 550$	24-M8 on $\Phi 420$
	TK540-220-42C	570	570	450	447.6	406	40	310	240	24-M8 on $\Phi 550$	24-M8 on $\Phi 420$

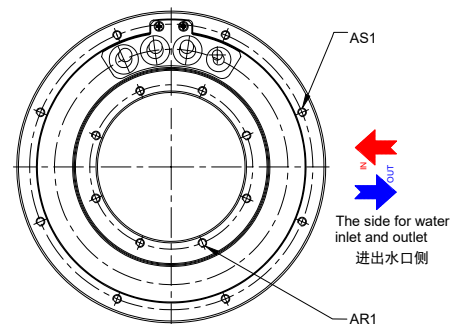
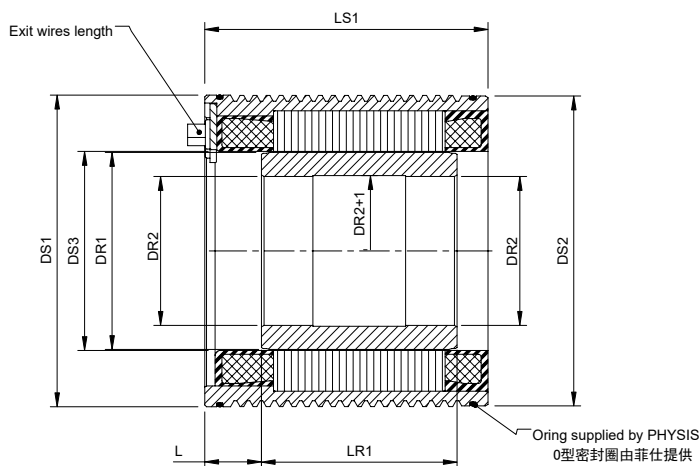

TK570

性能参数

电机系列 Motor Serial	电机规格 Motor Type	额定扭矩 Rated Torque (Nm)	额定转速 Rated Speed (rpm)	额定功率 Rated Power (kW)	额定电流 Rated Current (A)	峰值扭矩 Max Torque (Nm)	峰值电流 Max Current (A)	最高转速 Max Speed (rpm)	扭矩常数 Kt (Nm/A)
TK570	TK570-210-058C	3050	28	8.9	55.9	7422	138	60	58.3
	TK570-300-65C	4200	50	22	69	10603	178	100	64.8
	TK570-450-26C	6100	160	102.2	262	15904	770	800	26.2

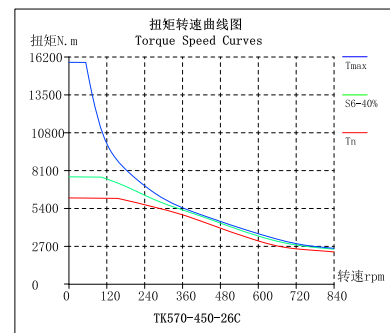
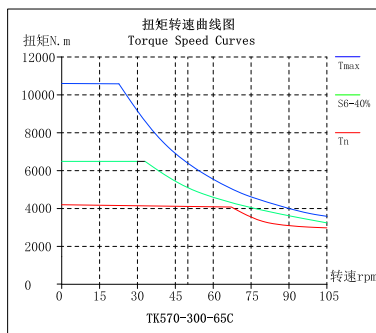
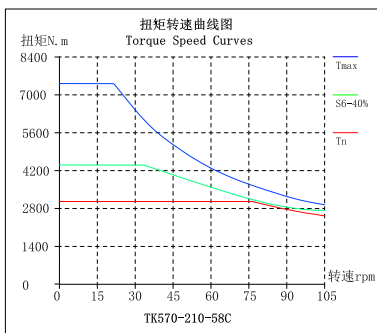

尺寸参数

电机系列 Motor Serial	电机规格 Motor Type	DS1	DS2	DS3	DR1	DR2	L	LS1	LR1	AS1	AR1
TK570	TK570-210-058C	587	586	500	497.4	446	22	265	230	24-M6 on Φ 570	16-M8 on Φ 470
	TK570-300-65C	595	595	500	498.2	445	33	380	320	16-M10 on Φ 576	16-M10 on Φ 470
	TK570-450-26C	595	594	500	497.8	200	60	550	470	16-M10 on Φ 574	16-M10 on Φ 465

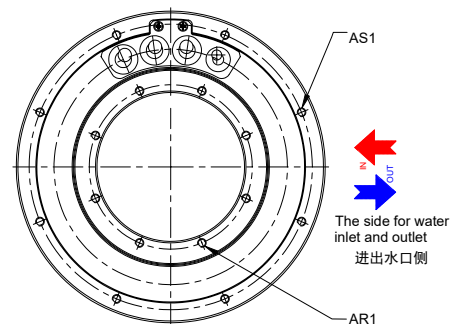
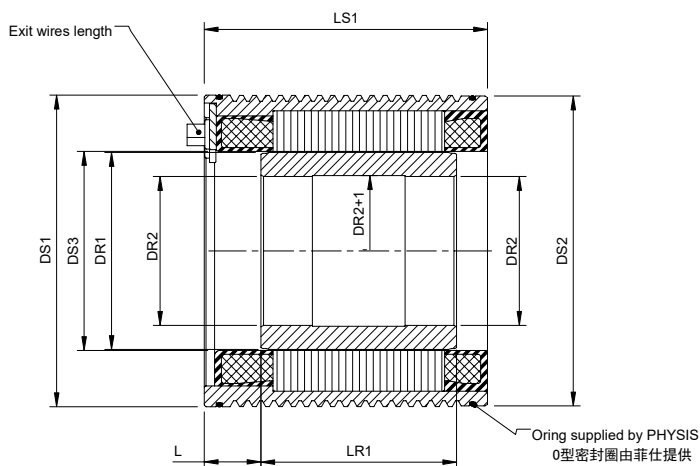

TK Series DD Servo Motors

TK615

性能参数

电机系列 Motor Serial	电机规格 Motor Type	额定扭矩 Rated Torque (Nm)	额定转速 Rated Speed (rpm)	额定功率 Rated Power (kW)	额定电流 Rated Current (A)	峰值扭矩 Max Torque (Nm)	峰值电流 Max Current (A)	最高转速 Max Speed (rpm)	扭矩常数 Kt (Nm/A)
TK615	TK615-260-23C	5100	250	133.6	229	14218	865	306	23.48
	TK615-470-18C	8248	300	259.1	486.5	21000	1326	600	18

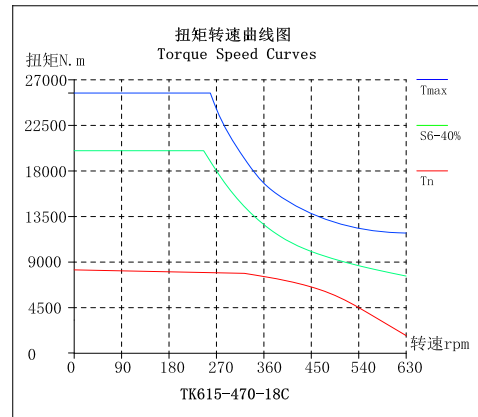
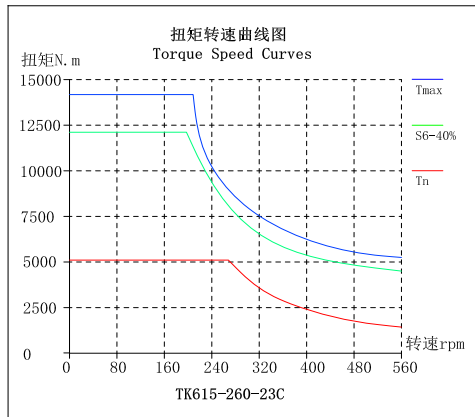

尺寸参数

电机系列 Motor Serial	电机规格 Motor Type	DS1	DS2	DS3	DR1	DR2	L	LS1	LR1	AS1	AR1
TK615	TK615-260-23C	780	710	535	532.5	200	40	500	280	14-M16 on Φ 739	12-M12 on Φ 480
	TK615-470-18C	780	710	535	532.5	200	40	690	490	14-M16 on Φ 739	12-M12 on Φ 480

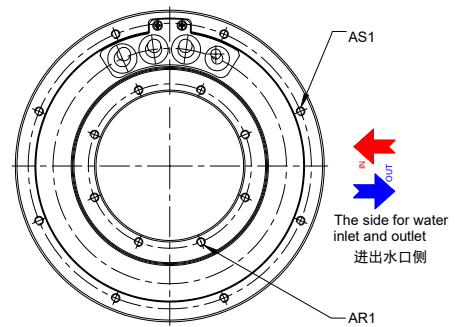
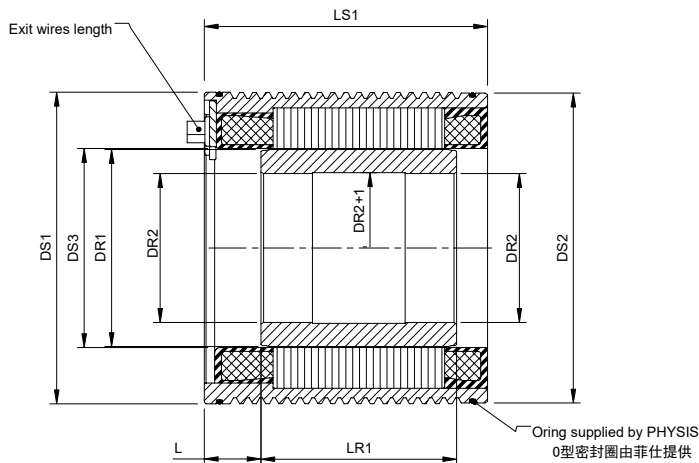

TK795

性能参数

电机系列 Motor Serial	电机规格 Motor Type	额定扭矩 Rated Torque (Nm)	额定转速 Rated Speed (rpm)	额定功率 Rated Power (kW)	额定电流 Rated Current (A)	峰值扭矩 Max Torque (Nm)	峰值电流 Max Current (A)	最高转速 Max Speed (rpm)	扭矩常数 Kt (Nm/A)
TK795	TK795-120-95C	4700	50	24.6	53	10200	200	90	92.8
	TK795-170-100C	6179	35	22.6	70.4	11442	134.4	64	106.4
	TK795-400-168C	12500	25	32.7	85	26923	214	37	168

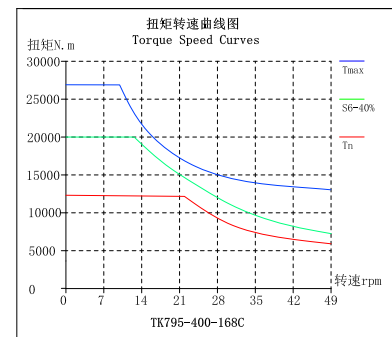
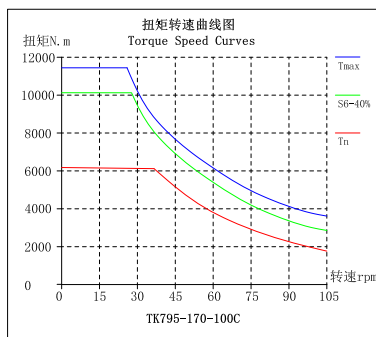
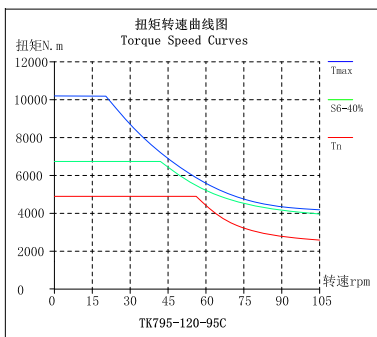

尺寸参数

电机系列 Motor Serial	电机规格 Motor Type	DS1	DS2	DS3	DR1	DR2	L	LS1	LR1	AS1	AR1
TK795	TK795-120-95C	825	825	690	686.8	630	35	215	154	16-M12 on Φ 798	4-M12 on Φ 650
	TK795-170-100C	825	825	690	686.8	630	37	265	200	16-M12 on Φ 798	4-M12 on Φ 650
	TK795S-400-168C	830	830	690	688.8	630	37	495	430	16-M12 on Φ 798	4-M12 on Φ 650

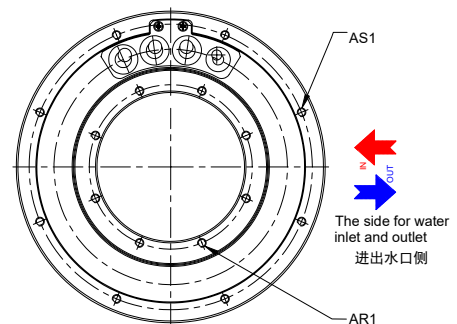
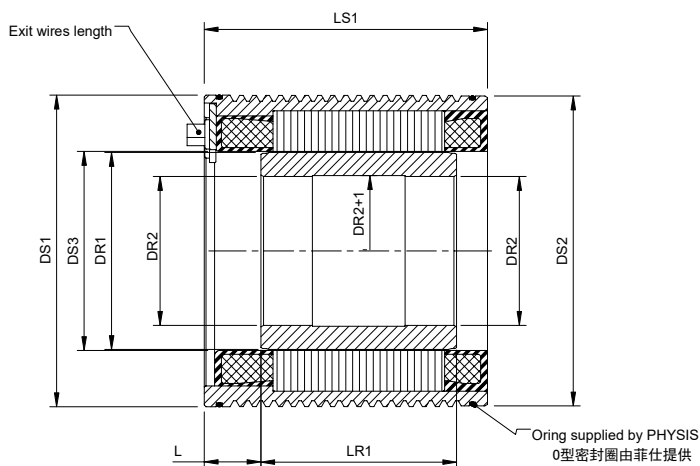

TK1340

性能参数

电机系列 Motor Serial	电机规格 Motor Type	额定扭矩 Rated Torque (Nm)	额定转速 Rated Speed (rpm)	额定功率 Rated Power (kW)	额定电流 Rated Current (A)	峰值扭矩 Max Torque (Nm)	峰值电流 Max Current (A)	最高转速 Max Speed (rpm)	扭矩常数 Kt (Nm/A)
TK1340	TK1340-250-284C	27500	12	34.6	110	49200	240	20	284

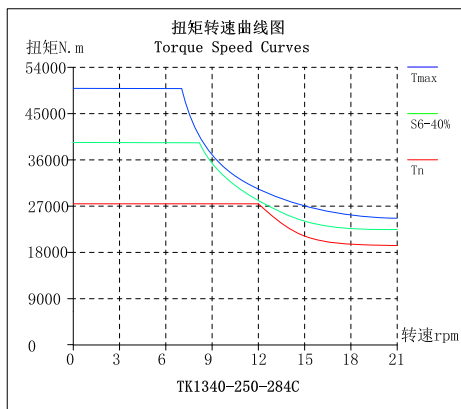

尺寸参数

电机系列 Motor Serial	电机规格 Motor Type	DS1	DS2	DS3	DR1	DR2	L	LS1	LR1	AS1	AR1
TK1340	TK1340-250-284C	1370	1370	1240	1234	1000	40	500	280	36-M20 on Φ 1352	20-M38 on Φ 1020

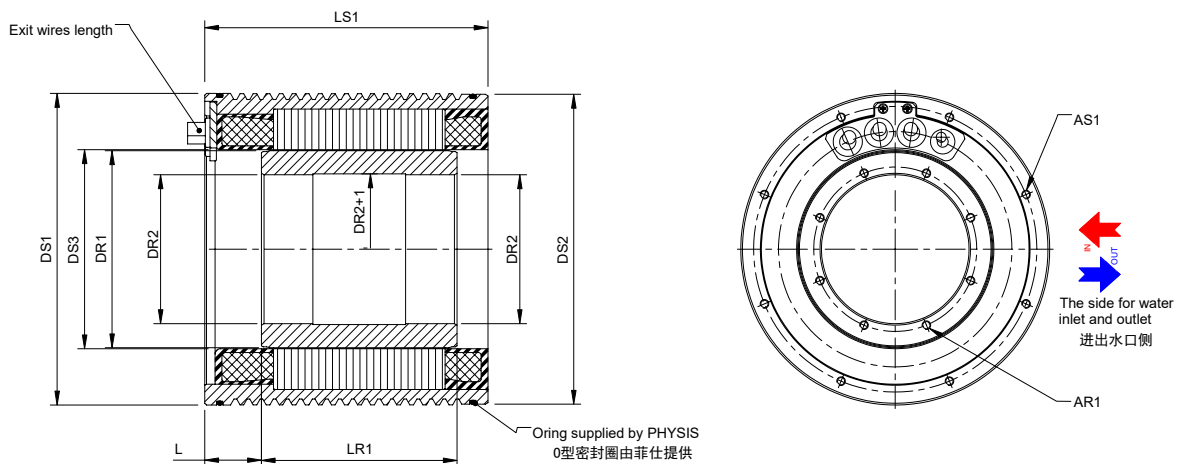

TK1700

性能参数

电机系列 Motor Serial	电机规格 Motor Type	额定扭矩 Rated Torque (Nm)	额定转速 Rated Speed (rpm)	额定功率 Rated Power (kW)	额定电流 Rated Current (A)	峰值扭矩 Max Torque (Nm)	峰值电流 Max Current (A)	最高转速 Max Speed (rpm)	扭矩常数 Kt (Nm/A)
TK1700	TK1700-550-68C	95700	90	902	1589	155900	3259	150	68

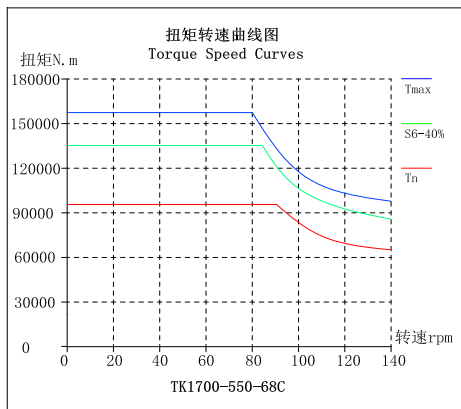

尺寸参数

电机系列 Motor Serial	电机规格 Motor Type	DS1	DS2	DS3	DR1	DR2	L	LS1	LR1	AS1	AR1
TK1700	TK1700-550-68C	1810	1810	1502	1459	1360	42	830	617	36-M20 on Φ 1721	20-M38 on Φ 1290

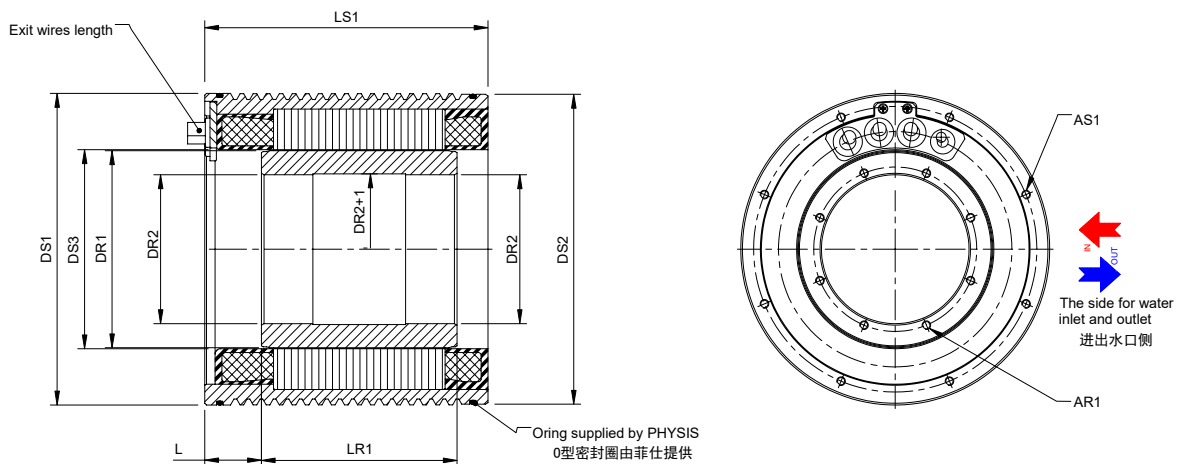

联系我们 Contact Information

菲仕总部 PHYSIS HEADQUARTER

宁波菲仕技术股份有限公司
Ningbo Physis Technology Co., Ltd.
浙江省宁波市北仑区小港安居路 308 号
No.308, Xiaogang Anju Road, Beilun District, Ningbo, China
总台热线 /Tel: +0086-(0)574-26922600

市场销售 Marketing & Sales

销售热线 /Tel: +0086-(0)574-23459197
邮箱 /E-mail: Sales@physis.com.cn

售后服务 After Sales

服务热线 /Tel: +0086-(0)574-23459183
邮箱 /E-mail: Aftersales@physis.com.cn



扫一扫了解更多

版本编号：PHMTSM2309-V04

由于产品的不断更新和改进，本产品型录中的部分产品数据信息会产生变化，为了能提供更好的服务，建议您在查阅本产品型录的同时，请联系我们，以便您及时获得最新的资讯。

All technical data, drawings and product information contained here may be subject to change, in order to provide you with a continuously improved products, please contact with us for up to date information.