



AxN

CONFIGURABLE MOTION CONTROL PLATFORM

Installation Manual

Support Model:

AxN Size5: AxN 090.150.4, AxN 110.200.4,

AxN 110.250.4, AxN 150.300.4

Version: V1.5
141100000036

Summary

| | |
|---|-----------|
| 1. Mechanical Installation | 2 |
| 1.1 Notes for Operation | 2 |
| 1.2 Installation Enviroment | 2 |
| 1.3 Overall Dimensions | 3 |
| 1.4 Installation Orientation | 3 |
| 1.5 Installation Spacing | 4 |
| 2. Main Circuit Wiring | 5 |
| 2.1 AC Power Supply Input | 5 |
| 2.1.1 AC Power Supply Requirement | 5 |
| 2.1.2 AC Power Supply Cable Febrication | 5 |
| 2.1.3 AC Power Supply Input Installation | 7 |
| 2.2 DC Power Supply Input | 9 |
| 2.2.1 DC Power Supply Requirement | 9 |
| 2.2.2 DC Power Supply Cable Fabrication | 9 |
| 2.2.3 DC Power Supply Input Installation | 11 |
| 2.3 Brake Resistor | 13 |
| 2.3.1 Internal Brake Resistor | 13 |
| 2.3.2 Internal Brake Resistor Installation | 13 |
| 2.3.3 External Brake Resistor | 14 |
| 2.3.4 External Brake Resistor Installation | 14 |
| 2.4 Motor Power Output | 16 |
| 2.4.1 Motor Power Output Cable Fabrication | 16 |
| 2.4.2 Motor Power Output Installation | 18 |
| 3. Control Circuit Wiring | 20 |
| 3.1 Auxiliary Power Supply (AUX_Power) | 20 |
| 3.1.1 Auxiliary Power Supply Requirement | 20 |
| 3.1.2 Auxiliary Power Supply Cable Fabrication | 20 |
| 3.1.3 Auxiliary Power Supply Installation | 20 |
| 3.2 STO Function | 21 |
| 3.3 System Relay (R1) | 23 |
| 4. Communication Port | 24 |
| 4.1 Overview of Communication Port Panel | 24 |
| 4.2 Main Encoder Port (E1) | 24 |
| 4.2.1 Sincos Encoder | 25 |
| 4.2.2 Endat Encoder | 25 |
| 4.2.3 Digital Incremental Encoder with Hall | 26 |
| 4.2.4 Resolver | 26 |
| 4.2.5 Hiperface Encoder | 26 |
| 4.3 S1 - Serial Bus Port | 26 |
| 4.3.1 RS-232 | 27 |
| 4.3.2 RS422/485 | 29 |
| 4.3.3 Auxiliary CAN | 29 |
| 4.4 C1 - Main CAN Port | 30 |
| 4.4.1 Main CAN | 31 |
| 4.4.2 Auxiliary Encoder | 32 |
| 4.5 EtherCAT IN/OUT - EtherCAT Port | 32 |
| 4.6 U1/U2 - User Connectors | 33 |
| 4.7 U3/U4 - Insulated User Connectors | 35 |
| 5. APPENDIX: ACCESSORIES | 37 |
| 5.1 Prefabricated Motor Power Output Cable | 37 |
| 5.2 Prefabricated Encoder Cable (for Physis Motors) | 38 |

1. MECHANICAL INSTALLATION

1.1 Notes for Operation

Avoid

Please be sure to avoid:

1. penetration of damp into the device;
2. aggressive or conductive substances in the immediate vicinity;
3. explosive and flammable substances in the immediate vicinity;
4. drill chippings, screws or foreign bodies dropping into the device;
5. ventilation openings being covered over, as otherwise the device may be damaged

Note

Note the following points:

1. Make sure every part of the drive is anchored before moving the drive. Failure to comply may result in minor or moderate injury from the drive parts falling;
2. Observe proper electrostatic discharge (ESD) procedures when handling the drive. Failure to comply could result in ESD damage to the drive circuitry;
3. Prevent foreign matter such as metal shavings or wire clippings from falling into the drive during installation and project construction. Failure to comply could result in damage to the drive. Place a temporary cover over the top of the drive during installation. Remove the temporary cover before start-up, as the cover will reduce ventilation and cause the drive to overheat. Install proper cooling to ensure the temperature in the enclosure does not exceed 40°C.

1.2 Installation Environment

To help prolong the optimum performance life of the drive, install the drive in the proper environment. The table below provides description of the appropriate environment for the drive.

| Environment | Condition |
|---------------------|---|
| Installation Area | Indoor |
| Ambient Temperature | 0°C to 40°C, up to 50°C with power reduction (2%/°C) Drive reliability improves in environments without wide temperature fluctuations. When using an enclosure panel, install a cooling fan or air conditioner in the area to ensure that the air temperature inside the enclosure does not exceed the specified levels. Do not allow ice to develop on the drive. |
| Humidity | 5 to 90% without condensation |
| Surrounding Area | Install the drive in an area free from: <ol style="list-style-type: none">1. oil mist and dust2. metal shavings, oil, water or other foreign materials3. radioactive materials4. combustible materials (e.g., wood)5. harmful gases and liquids6. excessive vibration7. chlorides |
| Altitude | Up to 1000m above MSL, over 1000 m above MSL with power reduction (3% per 100m) |
| Vibration | Amplitude up to 0.3mm at 2 to 9 Hz Acceleration up to 1m/s ² at 9 to 200 Hz |
| Orientation | Install the drive vertically to maintain maximum cooling effects. |

1.3 Overall Dimensions

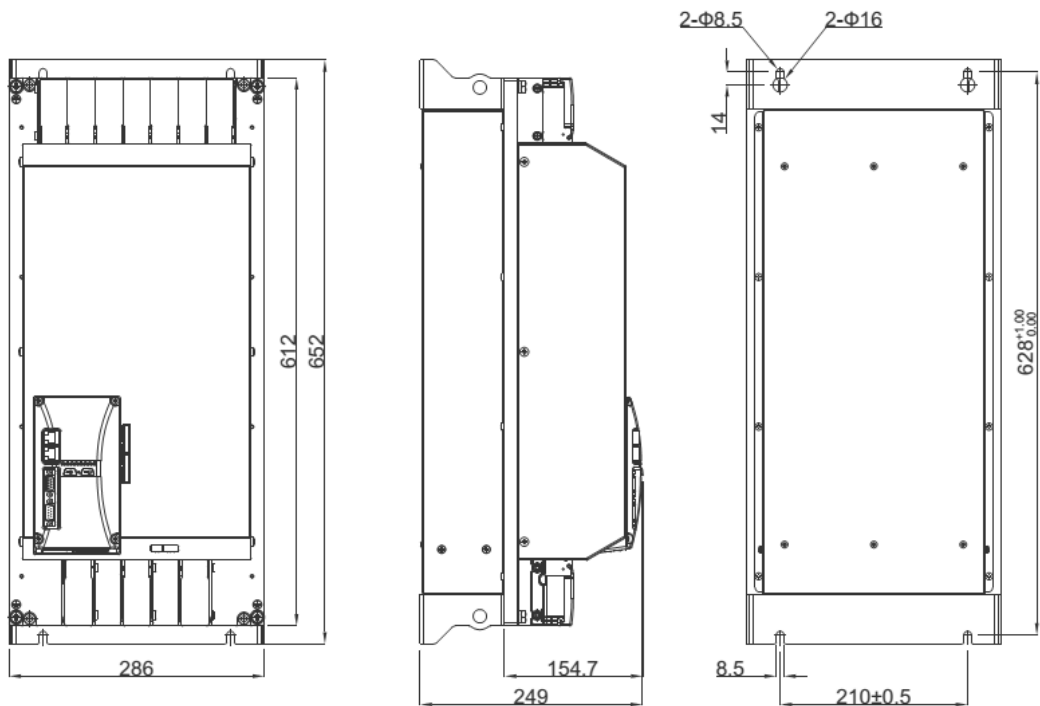

1.4 Installation Orientation

To maintain proper cooling, install the AxN drive upright inside the switch cabinet as illustrated below:

WARNING: The airflow inside the drive must be upright after installation as illustrated below. If other form of installation must be taken, CONNECT PHYSIS TECHNOLOGY ENGINEER BEFORE INSTALLATION.

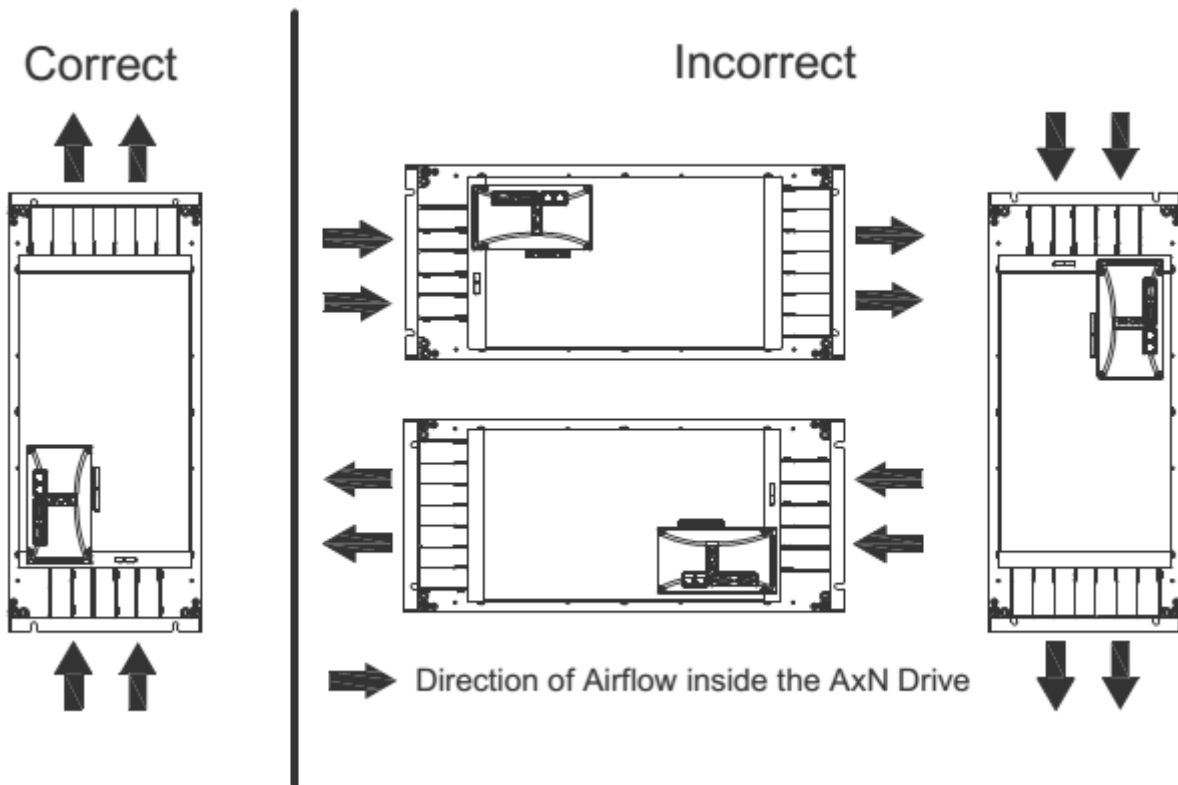

Installation Orientation of AxN Size5 Series Drive

1.5 Installation Spacing

To maintain sufficient space for airflow and wiring, the space between AxN drive and other device (including other AxN drives) must comply the requirement below.

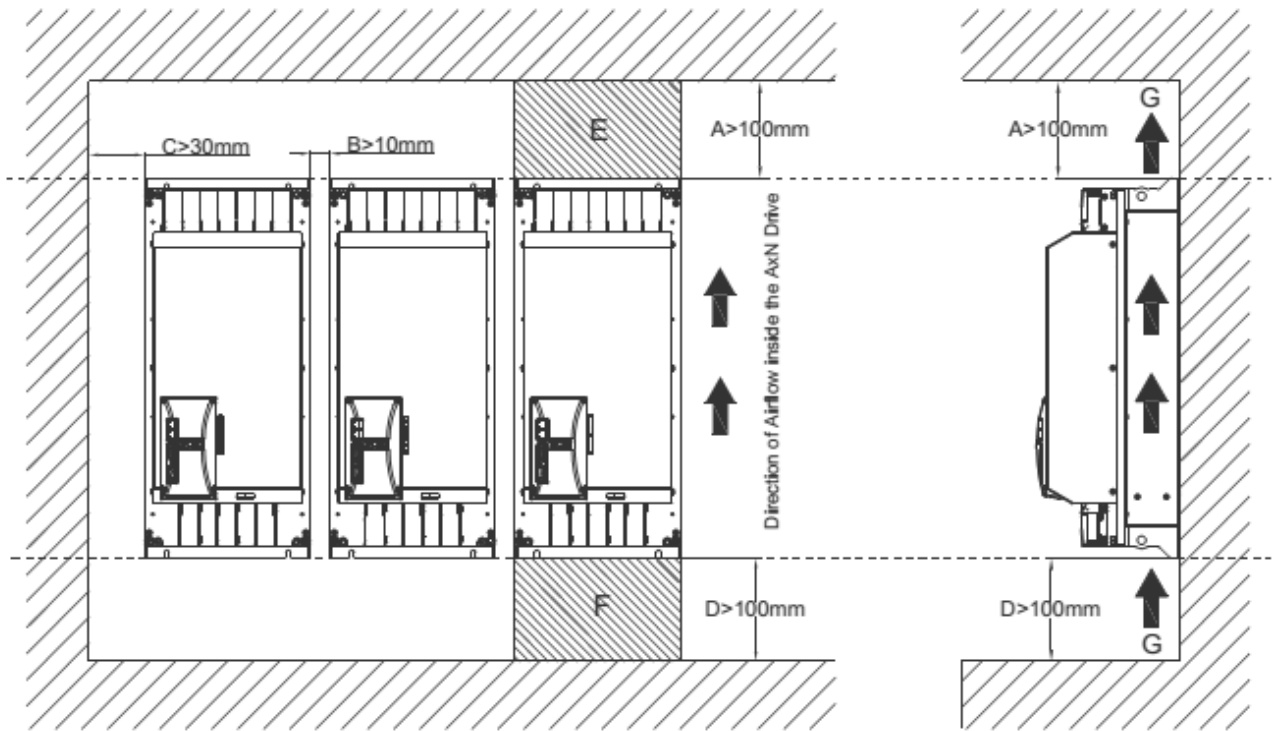

Installation Spacing of AxN Size5 Series Drive

| No. | Distance | Description |
|-----|----------|---|
| A | > 100mm | The distance between the top of the switch cabinet, to ensure enough space for air-out. |
| B | > 10mm | The distance between other device (including other AxN drives and peripheral devices) |
| C | > 30mm | The distance between the inside wall of the switch cabinet. |
| D | > 100mm | The distance between the bottom of the switch cabinet, to ensure enough space for air-in. |
| E | > 100mm | Air-out area, do not place any other device in this area |
| F | > 100mm | Air-in area, do not place any other device in this area |
| G | | Airflow Direction |

NOTE: The switch cabinet must have air outlets and inlets to ensure the thermal exchange between the cold air outside and the hot air inside.

2. MAIN CIRCUIT WIRING

2.1 AC Power Supply Input

2.1.1 AC Power Supply Requirement

| Mains Supply | AxN Size5 Series Drive |
|--------------------------|------------------------|
| Voltage | 150 ~ 500Vac |
| Type | Three-phase AC power |
| Frequency | 50/60Hz |
| Fluctuation of Frequency | ±10% (45 ~ 66Hz) |
| Asymmetry | ±3% |

2.1.2 AC Power Supply Cable Fabrication

AC power supply cable is the cable which connect the AxN Size5 Drive with the filter. The connection between AC power supply and the filter is not mentioned in this manual, and should be connected properly based on the real application.

Step 1: Cable Selection

AxN Size5 drive must use a 4 wire cable with shield as its AC power supply cable. Refer to the table below to select the appropriate cable:

| AxN Size5 | Current (A rms) | Recommended Gauge (mm ²) | Recommended Gauge (AWG) |
|---------------|-----------------|--------------------------------------|-------------------------|
| AxN 090.150.4 | 90 | 21.15 | 4 |
| AxN 110.200.4 | 110 | 26.67 | 3 |
| AxN 110.250.4 | 110 | 26.67 | 3 |
| AxN 150.300.4 | 150 | 33.62 | 2 |

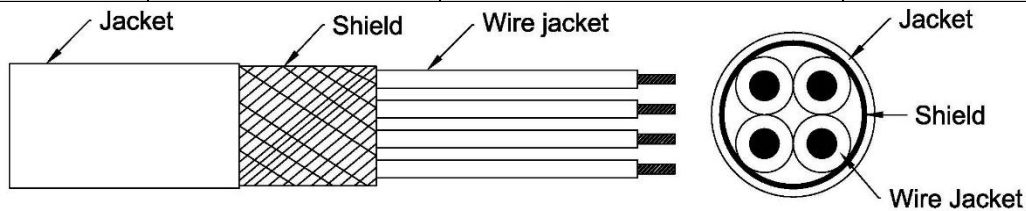

Step 2: Cable Length Measurement

The AC power supply cable is used to connect the output of the filter with the Power Input Port (P1) of AxN Size5 Drive. To minimize the interference, the filter must be installed in close proximity to AxN Size5 Drive as much as possible. But, the distance between two devices should also comply with the Installation Space Regulation of AxN Size5 Drive (Refer to [1.5 Installation Spacing](#)).

NOTE: The length of AC power supply cable should **NOT** exceed **0.5m**.

Step 3: Strip Cable Outside Jacket

Strip the outside jacket of AC power supply cable for 160mm and reveal the inside shield.

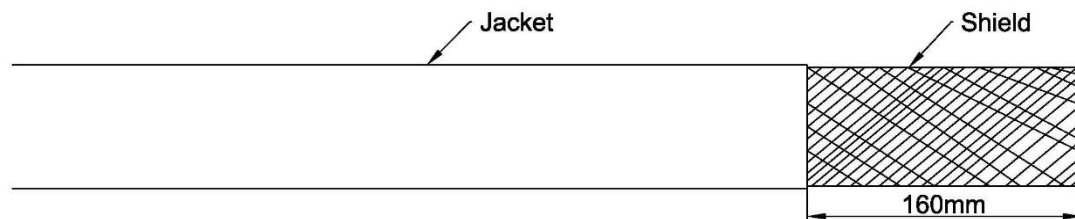

Step 4: Make Grounding Shield

Leave shield for 65mm as the grounding shield. Turn it to the outside of the jacket, then weld a wire on the shield as a drainage line.

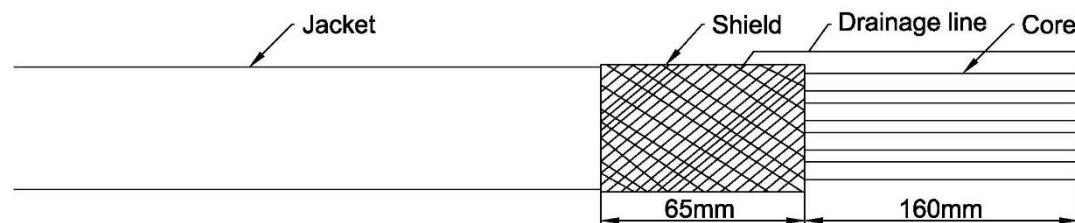

Step 5: Fix Grounding Shield

Use a 60mm heat-shrink tube to fix the grounding shield, in the meaning time leave 40mm shield outside.

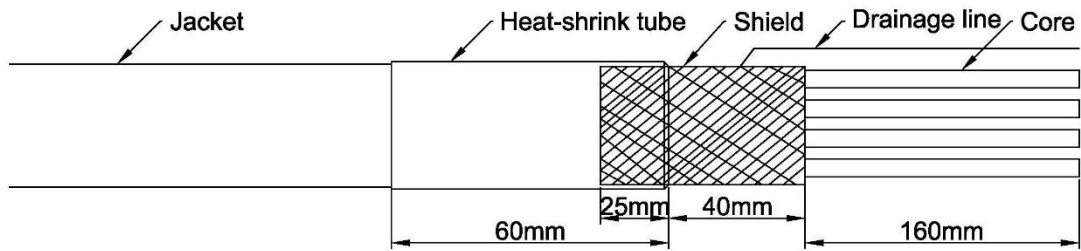

Step 6: Make Phase Wires

Choose 3 wires of the cable as the phase wires (R, S and T). Crimping pre-insulated Terminals on the wires will enhance the connection stability and simplicity between the cable and drive. AxN Size5 series drives are recommended to use the RNY Series Ring Terminals manufactured by KST. Refer to the following table to select the appropriate terminal:

| AxN Size5 | Ring Terminals | d2(mm) | W(mm) | F(mm) | E(mm) | D(mm) | d1(mm) |
|---------------|----------------|--------|-------|-------|-------|-------|--------|
| AxN 090.150.4 | RNYB22-8 | 8.4 | 16.5 | 13.5 | 24 | 13 | 7.7 |
| AxN 110.200.4 | RNYB22-8 | 8.4 | 16.5 | 13.5 | 24 | 13 | 7.7 |
| AxN 110.250.4 | RNYB22-8 | 8.4 | 16.5 | 13.5 | 24 | 13 | 7.7 |
| AxN 150.300.4 | RNYB22-8 | 8.4 | 16.5 | 13.5 | 24 | 13 | 7.7 |

Strip the wires for L mm ($1 \leq L \leq E$), the recommend strip length is $E/2$ mm, refer to the following table to select an appropriate length:

| AxN Size5 | Strip Length (mm) | Recommended Strip Length (mm) |
|---------------|-------------------|-------------------------------|
| AxN 090.150.4 | 1 ~ 24 | 12 |
| AxN 110.200.4 | 1 ~ 24 | 12 |
| AxN 110.250.4 | 1 ~ 24 | 12 |
| AxN 150.300.4 | 1 ~ 24 | 12 |

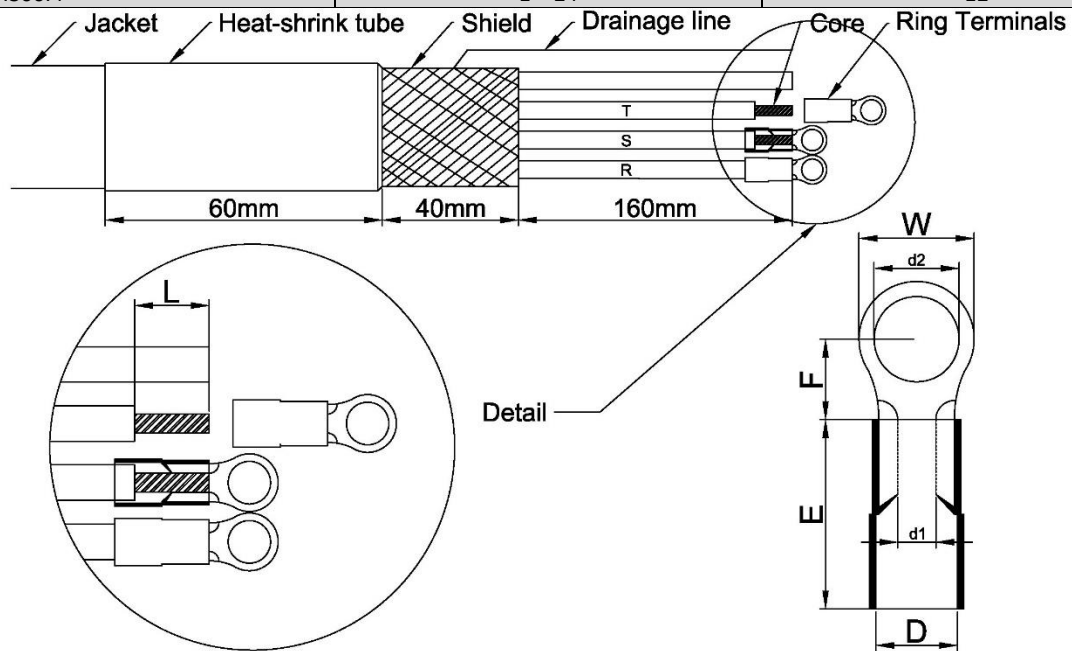

Step 7: Connect PE wire with Shield

Use the same method to make the remaining wire as the PE wire. Then crimp the PE wire into the Ring Terminal along with the drainage line. Refer to the following table to select the appropriate terminal:

| AxN Size5 | Ring Terminals | d2(mm) | W(mm) | F(mm) | E(mm) | D(mm) | d1(mm) |
|---------------|----------------|--------|-------|-------|-------|-------|--------|
| AxN 090.150.4 | RNYBS22-6 | 6.4 | 12.2 | 15.1 | 24 | 13 | 7.7 |
| AxN 110.200.4 | RNYBS22-6 | 6.4 | 12.2 | 15.1 | 24 | 13 | 7.7 |
| AxN 110.250.4 | RNYBS22-6 | 6.4 | 12.2 | 15.1 | 24 | 13 | 7.7 |
| AxN 150.300.4 | RNYBS22-6 | 6.4 | 12.2 | 15.1 | 24 | 13 | 7.7 |

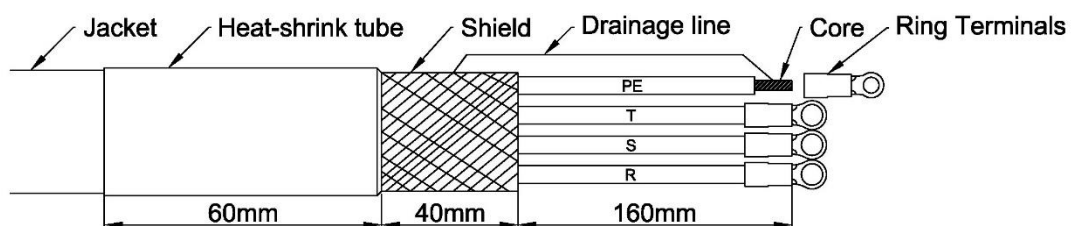

Step 8: Check and Mark

Check every wire and the connection between shield and PE wire, then label each wire.

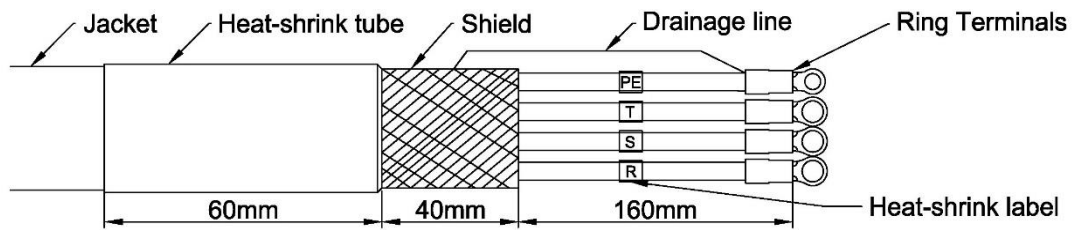

2.1.3 AC Power Supply Input Installation

Step 1: Check the Power Supply Type and Voltage

Make sure that the mains power supply is a 3 phase AC power supply, and its voltage is 150 ~ 500 Vac.

Step 2: Install the Filter

Connect the filter to the AC power supply. Then, connect one end of the AC power supply cable to the filter. Fuses or Breaker can be installed before the filter based on the real application.

NOTE: To minimize the interference, the filter must be installed in close proximity to AxN Size5 Drive as much as possible. But, the distance between two devices should also comply with the Installation Space Regulation of AxN Size5 Drive (Refer to [1.5 Installation Spacing](#)). The length of AC power supply cable should **NOT** exceed **0.5m**.

Step 3: Find out the AC Power Input Terminals

PE, T, S and R, these are the four terminals called AC Power Input Terminals. AxN Size5 Drive's AC Power Input Terminals are in the Power Supply Input Port (P1) which is on the top of the drive. Refer to the following figures for exact locations and terminal Assignment.

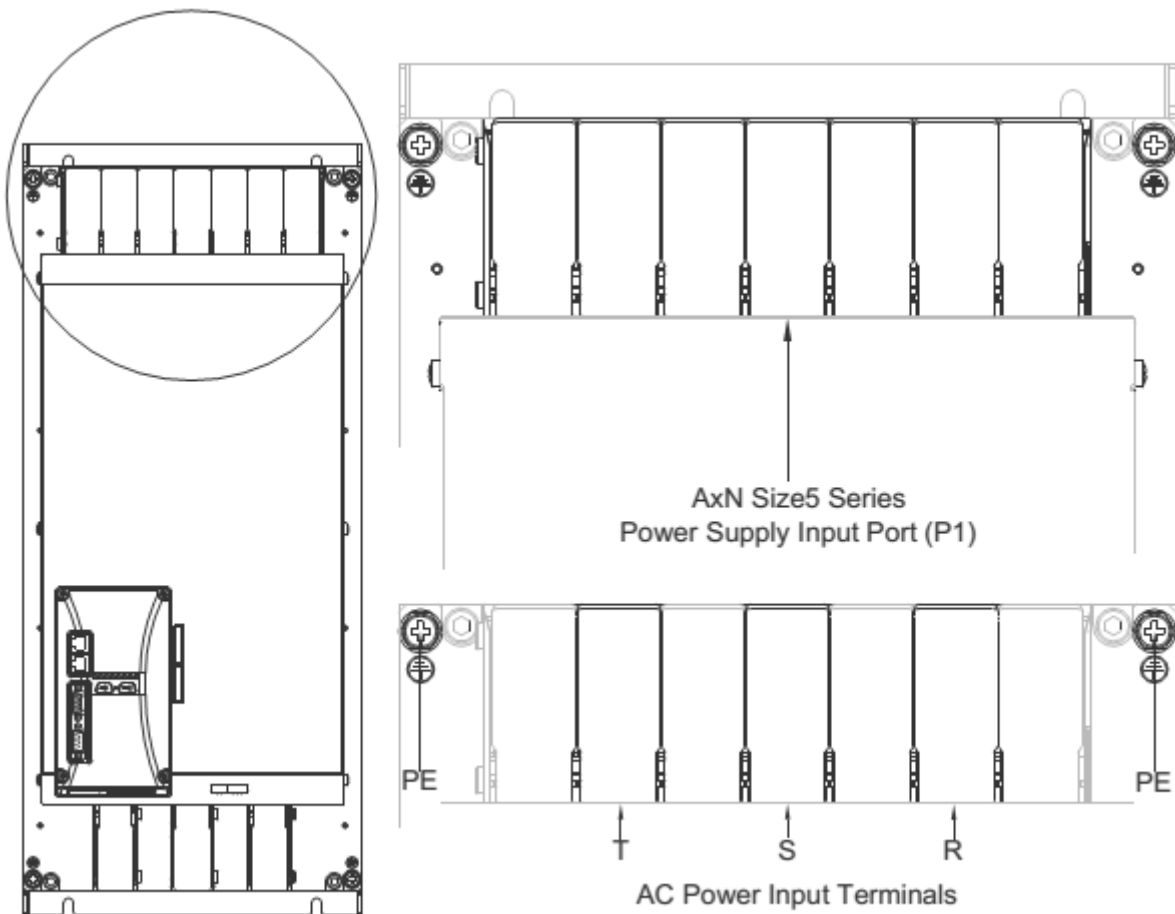

Step 4: Install Phase Wires (T, S and R)

1. Open the terminal cover and loosen the nuts on T, S and R terminals with torque wrench and s13mm socket;

2. The circular terminal of the corresponding conductor is sheathed on the stud in the corresponding terminal (for example, the T-phase conductor is sheathed in the T-phase terminal);
3. Then tighten the nuts on the T, S and R terminals with a torque wrench and socket, with a tightening torque of 8.0 ~ 15.0 N.m, and close the terminal cover.

Step 5: Install Grounding Wire

Loosen the grounding point (any one) on the machine body with an 8mm cross screwdriver, and fix the ground wire on the grounding point (PE).

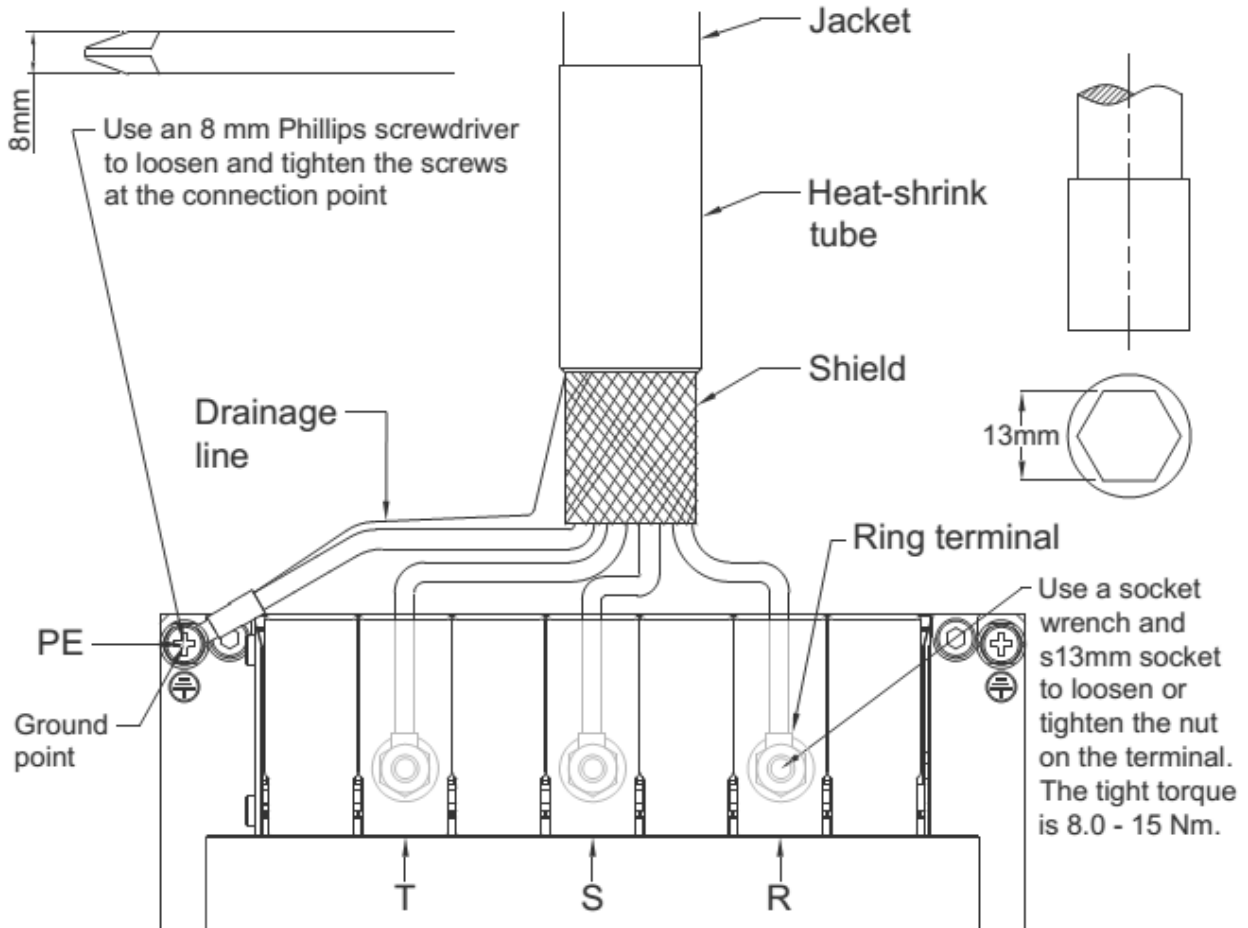

2.2 DC Power Supply Input

2.2.1 DC Power Supply Requirement

| Main Supply | AxN 090.150.4 | AxN 110.200.4 | AxN 110.250.4 | AxN 150.300.4 |
|------------------------|---------------|---------------|---------------|---------------|
| Voltage | 565V | | | |
| Type | DC power | | | |
| Fluctuation of Voltage | 0 ~ 800V | | | |
| Nominal Power | 62.4KW | 76.2KW | 76.2KW | 103.9KW |
| Peak Power | 103.9KW | 138.6KW | 190.5KW | 207.8KW |

2.2.2 DC Power Supply Cable Fabrication

DC power supply cable is the cable which connect the AxN Size5 Drive with the DC power supply. This manual only mention the cable fabrication of AxN drive side. The power supply side should be fabricated based on the requirement of the DC power supply

Step 1: Cable Selection

AxN Size5 drive must use a 3 wire cable with shield as its DC power supply cable. Refer to the table below to select the appropriate cable:

| AxN Size5 | Current (A rms) | Recommended Gauge (mm ²) | Recommended Gauge (AWG) |
|---------------|-----------------|--------------------------------------|-------------------------|
| AxN 090.150.4 | 110.4 | 26.67 | 3 |
| AxN 110.200.4 | 134.9 | 33.62 | 2 |
| AxN 110.250.4 | 134.9 | 33.62 | 2 |
| AxN 150.300.4 | 183.9 | 42.41 | 1 |

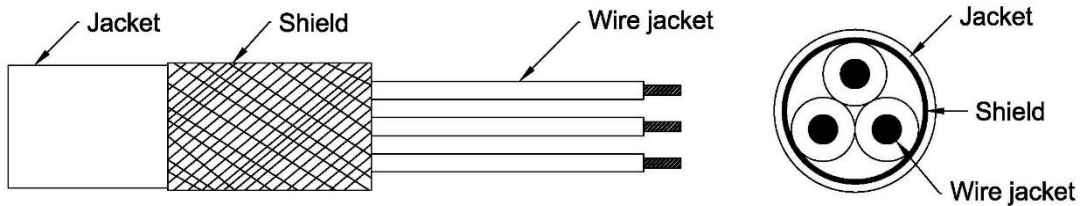

Step 2: Cable Length Measurement

The AC power supply cable is used to connect the output of the DC power supply with the Power Input Port (P1) of AxN Size5 Drive. To minimize the interference, the DC power supply must be installed in close proximity to AxN Size5 Drive as much as possible. But, the distance between two devices should also comply with the Installation Space Regulation of AxN Size5 Drive (Refer to [1.5 Installation Spacing](#)).

Step 3: Strip Cable Outside Jacket

Strip the outside jacket of the DC power supply cable for 160mm and reveal the inside shield.

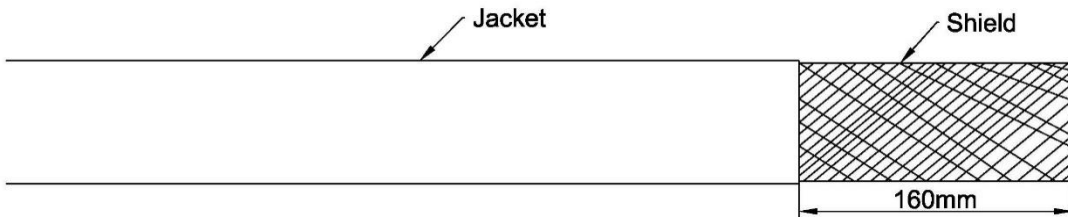

Step 4: Make Grounding Shield

Leave 65mm Shield as the grounding shield and turn it to the outside of the jacket. Then, weld a wire on the shield as the drainage line.

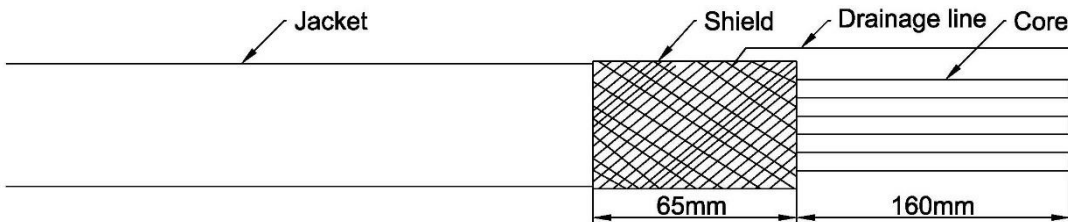

Step 5: Fix Grounding Shield

Use a 60mm heat-shrink tube to fix the grounding shield and leave 40mm shield outside.

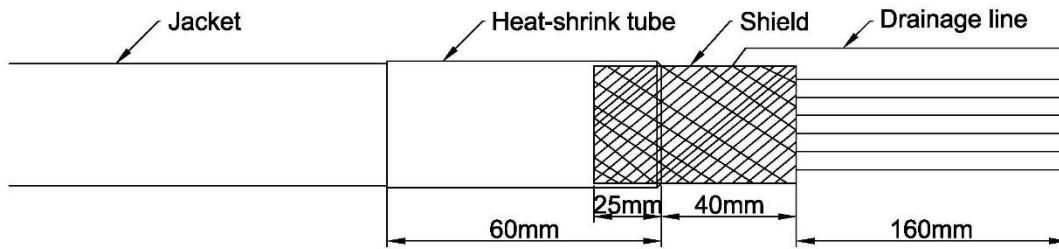

Step 6: Make Phase Wires

Choose 2 wires of the cable as DC+ and DC-. Crimping pre-insulated Terminals on the wires will enhance the connection stability and simplicity between the cable and drive. AxN Size5 series drives are recommended to use the RNY series Ring Terminals manufactured by KST. Refer to the following table to select the appropriate terminal:

| AxN Size5 | Ring Terminals | d2(mm) | W(mm) | F(mm) | E(mm) | D(mm) | d1(mm) |
|---------------|----------------|--------|-------|-------|-------|-------|--------|
| AxN 090.150.4 | RNYB22-8 | 8.4 | 16.5 | 13.5 | 24 | 13 | 7.7 |
| AxN 110.200.4 | RNYB22-8 | 8.4 | 16.5 | 13.5 | 24 | 13 | 7.7 |
| AxN 110.250.4 | RNYB22-8 | 8.4 | 16.5 | 13.5 | 24 | 13 | 7.7 |
| AxN 150.300.4 | RNYB22-8 | 8.4 | 16.5 | 13.5 | 24 | 13 | 7.7 |

Strip the wires for L mm ($1 \leq L \leq E$), the recommend strip length is E/2 mm, refer to the following table to select an appropriate length:

| AxN Size5 | Strip Length (mm) | Recommended Strip Length (mm) |
|---------------|-------------------|-------------------------------|
| AxN 090.150.4 | 1 ~ 24 | 12 |
| AxN 110.200.4 | 1 ~ 24 | 12 |
| AxN 110.250.4 | 1 ~ 24 | 12 |
| AxN 150.300.4 | 1 ~ 24 | 12 |

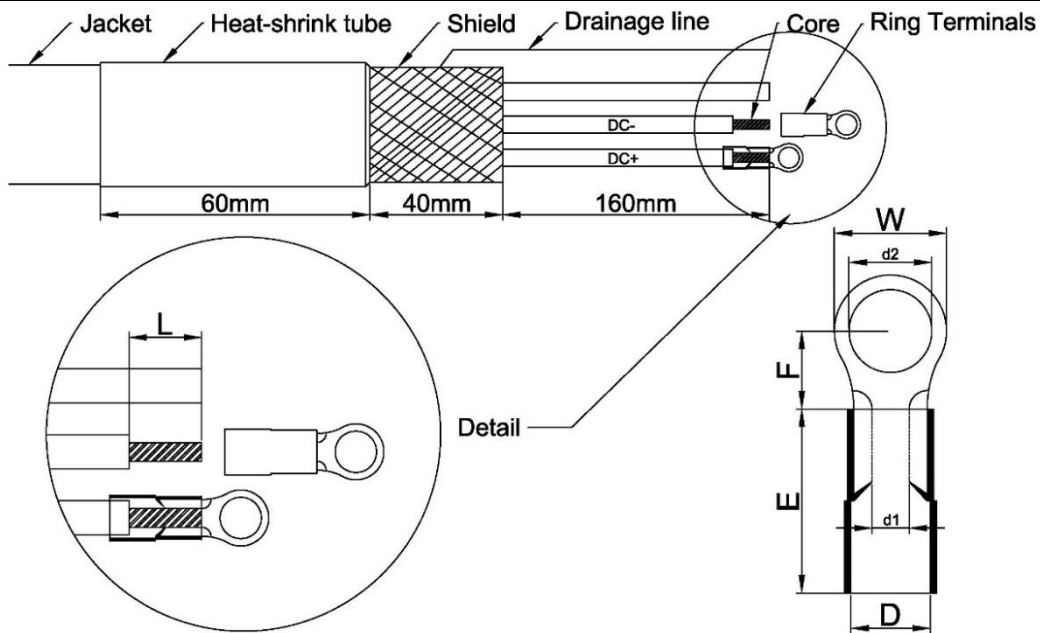

Step 7: Connect PE wire with Shield

Use the same method to make the remaining wire as the PE wire. Then crimp the PE wire into the Ring Terminal along with the drainage line. Refer to the following table to select the appropriate terminal:

| AxN Size5 | Ring Terminals | d2(mm) | W(mm) | F(mm) | E(mm) | D(mm) | d1(mm) |
|---------------|----------------|--------|-------|-------|-------|-------|--------|
| AxN 090.150.4 | RNYB22-8 | 6.4 | 12.2 | 15.1 | 24 | 13 | 7.7 |
| AxN 110.200.4 | RNYB22-8 | 6.4 | 12.2 | 15.1 | 24 | 13 | 7.7 |
| AxN 110.250.4 | RNYB22-8 | 6.4 | 12.2 | 15.1 | 24 | 13 | 7.7 |
| AxN 150.300.4 | RNYB22-8 | 6.4 | 12.2 | 15.1 | 24 | 13 | 7.7 |

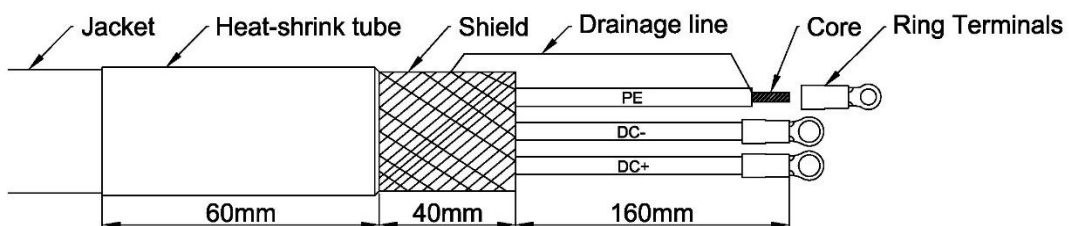

Step 8: Check and Mark

Check every wire and the connection between shield and PE wire, then label each wire.

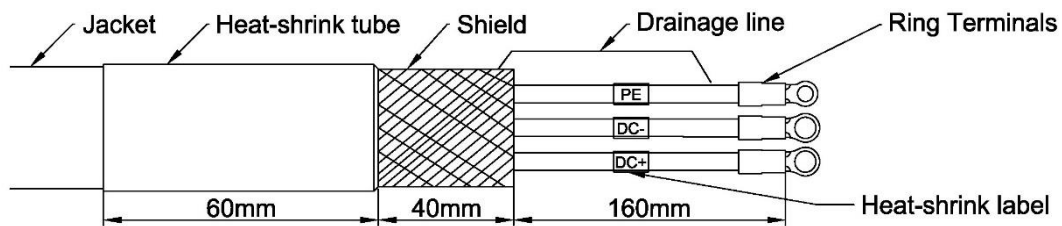

2.2.3 DC Power Supply Input Installation

Step 1: Check the Power Supply Type and Voltage

Make sure that the mains power supply is a DC power supply, and its voltage is 0 ~ 800 Vdc.

Step 2: Find out the DC Power Input Terminals

PE, DC+/B+ and DC-, these are the three terminals called DC Power Input Terminals. AxN Size5 Drive's DC Power Input Terminals are in the Power Supply Input Port (P1) which is on the top of the drive. Refer to the following figures for exact locations and terminal Assignment.

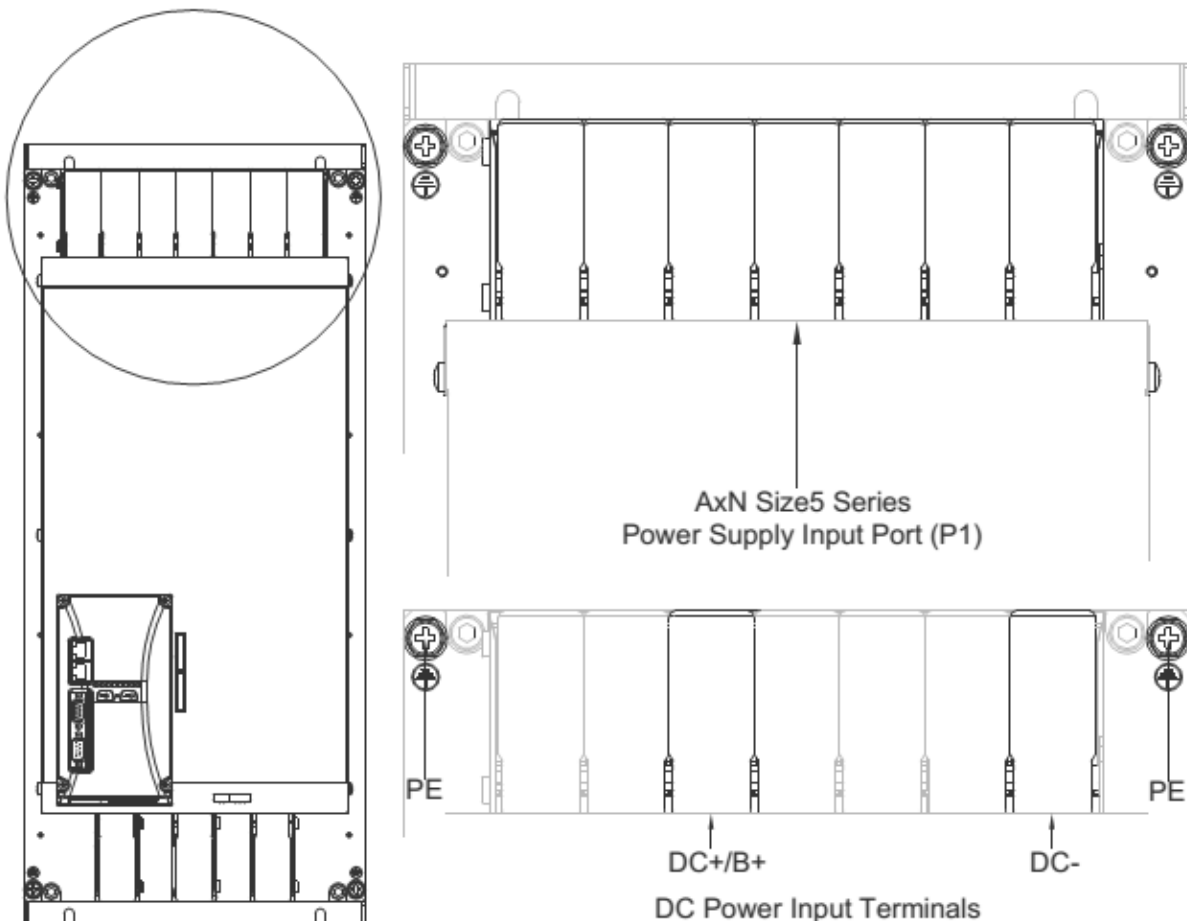

Step 3: Install DC Power Wires (DC+ and DC-)

1. Open the terminal cover and loosen the nuts on DC+/B+ and DC- terminals with torque wrench and s13mm socket;
2. The circular terminal of the corresponding conductor is sheathed on the stud in the corresponding terminal (for example, the DC+ -phase conductor is sheathed in the DC+/B+ terminal);
3. Then tighten the nuts on the DC+/B+ and DC- terminals with a torque wrench and socket, with a tightening torque of 8.0 ~ 15.0 N.m, and close the terminal cover.

Step 4: Install Grounding Wire

Loosen the grounding point (any one) on the machine body with an 8mm cross screwdriver, and fix the ground wire on the grounding point(PE).

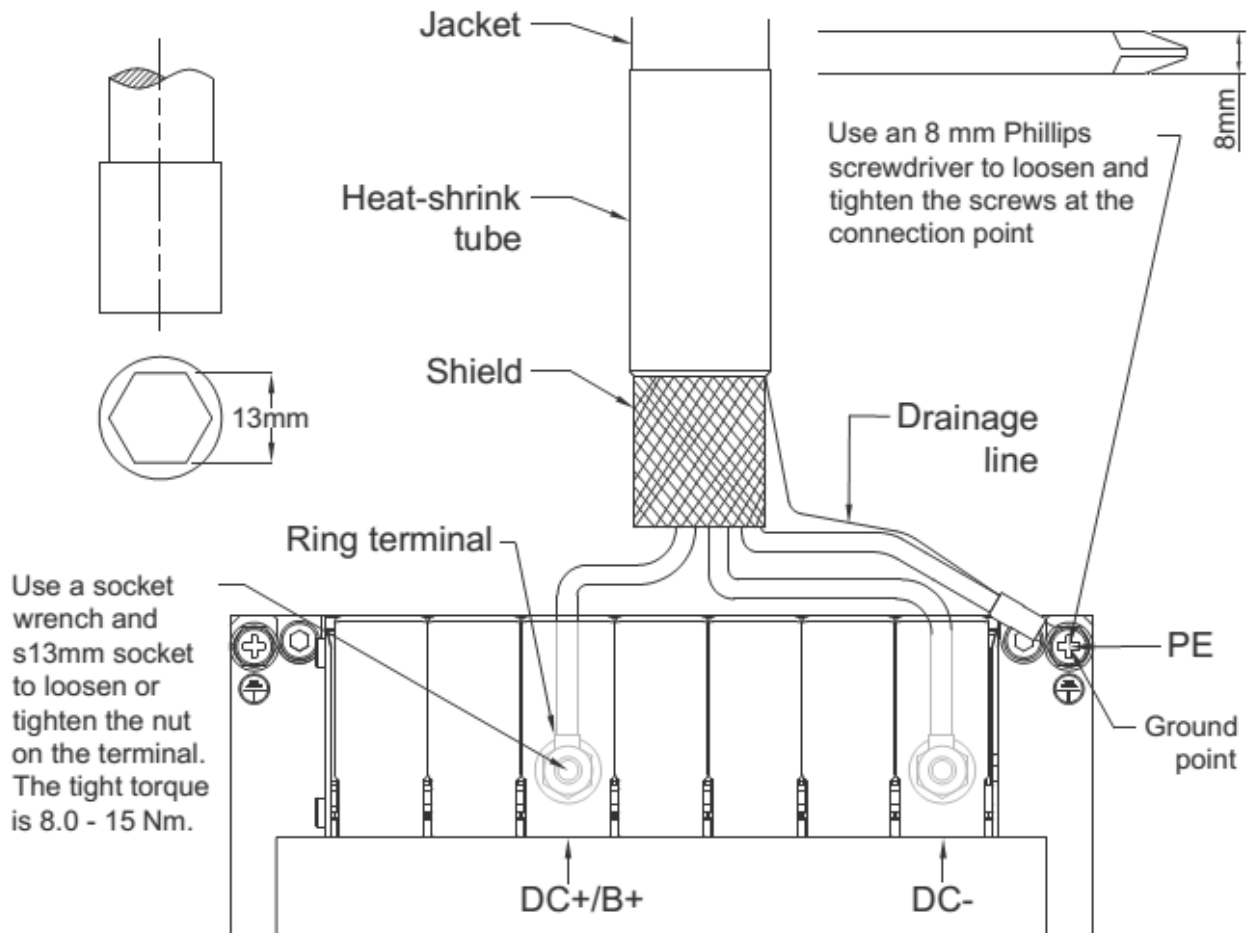

2.3 Brake Resistor

Dynamic braking (DB) helps bring the motor to a smooth and rapid stop when working with high inertia loads. As the drive lowers the frequency of a motor with high inertia connected, regeneration occurs. This can cause an overvoltage situation when the regenerative energy flows back into the DC bus capacitors. A brake resistor prevents these overvoltage faults.

AxN Series Drive has an internal brake resistor inside the drive. And it can also connect an external brake resistor (Recommended).

WARNING: Do not operate AxN Drive without any brake resistor. Failure to comply may result in damage to braking circuit or drive.

2.3.1 Internal Brake Resistor

Every AxN Series Drive has an internal brake resistor. Regard to its properties, using internal brake resistor in real applications is

NOT recommended. Refer to the following table for more details:

| AxN Size5 | Resistance (Ω) | Power (W) |
|---------------|-------------------------|-----------|
| AxN 090.150.4 | 3.5 | 150 |
| AxN 110.200.4 | 3 | 150 |
| AxN 110.250.4 | 3 | 150 |
| AxN 150.300.4 | 3 | 150 |

2.3.2 Internal Brake Resistor Installation

Step 1: Find out the Internal Brake Resistor Terminals

DC+/B+ and Jump, these are the two terminals called Internal Brake Resistor Terminals. AxN Size5 Drive's Internal Brake Resistor Terminals are in the Power Supply Input Port (P1) which is on the top of the drive. Refer to the following figures for exact locations and terminal Assignment.

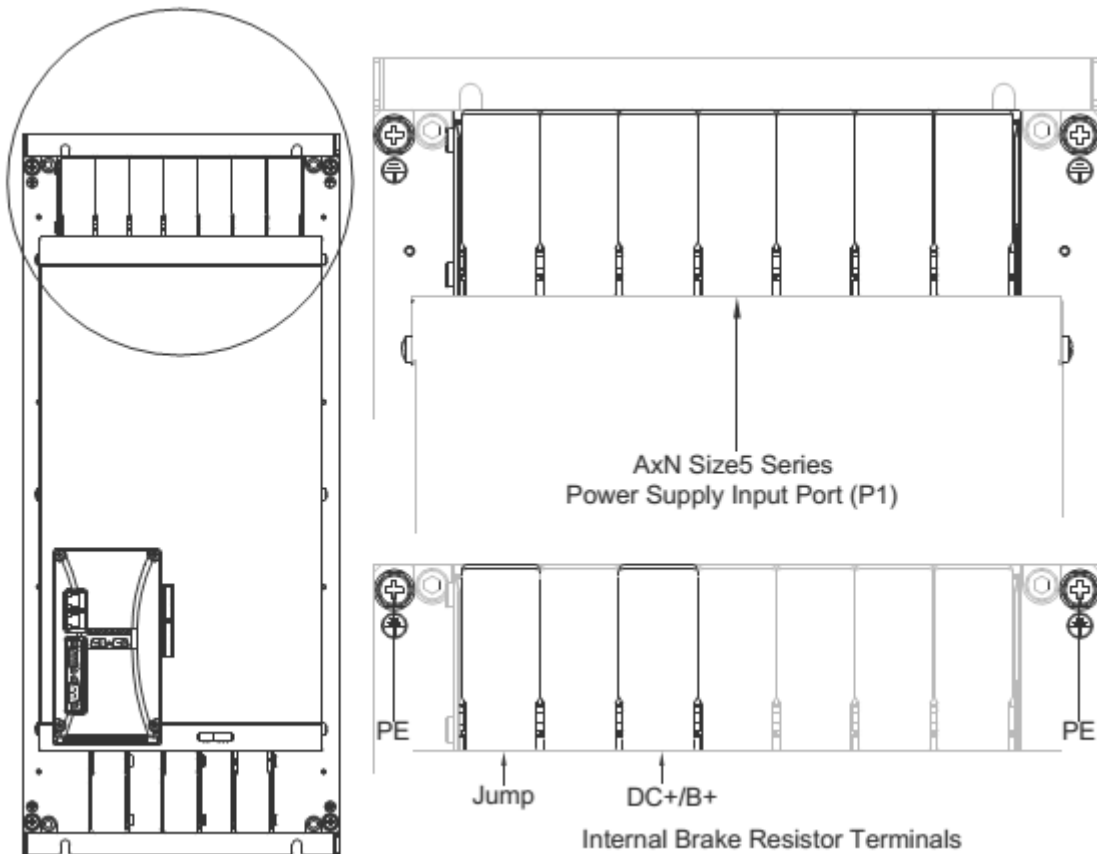

Step 2: Shortcut Jump and DC+/B+

Open the terminal cover, loosen the nuts on Jump and DC + / B + terminals with torque wrench and s13mm socket, and short circuit Jump and DC + / B + with a wire.

NOTE: The shortcut wire is already provided in the accessories, as illustrated in the following figure.

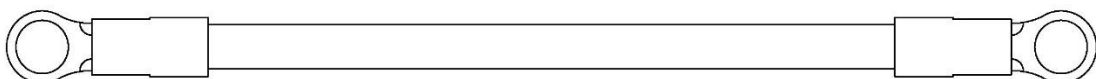

Step 3: Tight the Terminals

Then tighten the nuts on the Jump and DC + / B + terminals with a torque wrench and socket. The tightening torque is 8.0 ~ 15.0 N.m, close the terminal cover.

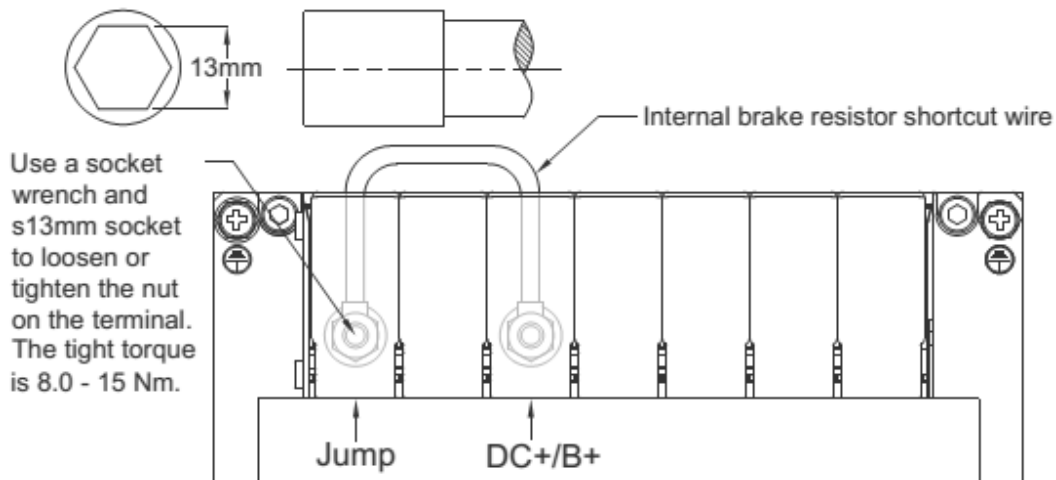

2.3.3 External Brake Resistor

The External Brake Resistor must be sized properly in order to dissipate the required power to decelerate the load in desired time. There are three important factors: **Resistance, Maximum Absorb Energy** and **Maximum Power**.

Resistance

The selection of the external brake resistor resistance must be proper. If the resistance is smaller than Minimum Resistance, the IGBT might be damaged by the overload brake current. And if the resistance is bigger than Maximum Resistance, the brake procedure might be abort because of the high DC-Bus Voltage (over 900V).

Refer to following table to check the Minimum and Maximum Resistance of external brake resistor which is suitable for a particular drive:

| AxN Size5 | Minimum Resistance (Ω) | Maximum Resistance (Ω) |
|---------------|---------------------------------|---------------------------------|
| AxN 090.150.4 | 3 | 3.7 |
| AxN 110.200.4 | 3 | 3 |
| AxN 110.250.4 | 3 | 3 |
| AxN 150.300.4 | 3 | 3 |

Maximum Absorb Energy and Maximum Power

Maximum Absorb Energy and Maximum Power are two important factors to evaluate the energy absorption ability of the brake resistor. The values of these two factors may differ from one application to another, but the basic idea is always the same, to dissipate the required power to decelerate the load in desired time.

NOTE: Brake resistor wires' insulation grade must be higher than 1000Vac and 3000Vdc.

2.3.4 External Brake Resistor Installation

Step 1: Check the Brake Resistor

Check the external brake resistor's resistance, maximum absorb energy and maximum power. Make sure that the brake resistor is suitable for AxN Size5 Drive and real application.

Step 2: Fabricate Brake Resistor Wires

In order to install the brake resistor to AxN Size5 Drive, the brake's wire should be clamped ring terminals to fit the terminals on drive. AxN Size5 series drives are recommended to use the RNY series Ring Terminals manufactured by KST. And the recommended strip length is 14mm. Refer to following figure and table for more detail.

| Ring Terminal | d2 (mm) | W (mm) | F (mm) | E (mm) | D (mm) | d1 (mm) |
|---------------|---------|--------|--------|--------|--------|---------|
| RNYB 22-8 | 8.4 | 16.5 | 13.5 | 24 | 13 | 7.7 |

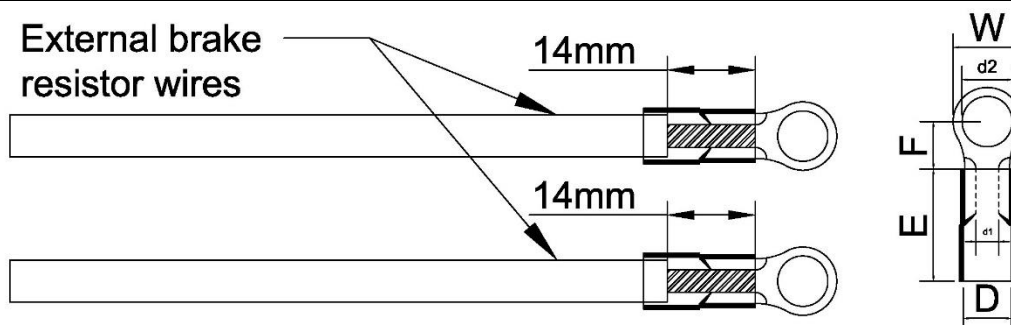

Step3: Find out the External Brake Resistor Terminals

DC+/B+ and B-, these are the two terminals called External Brake Resistor Terminals. AxN Size5 Drive's Internal Brake Resistor Terminals are in the Power Supply Input Port (P1) which is on the top of the drive. Refer to the following figures for exact locations and terminal Assignment.

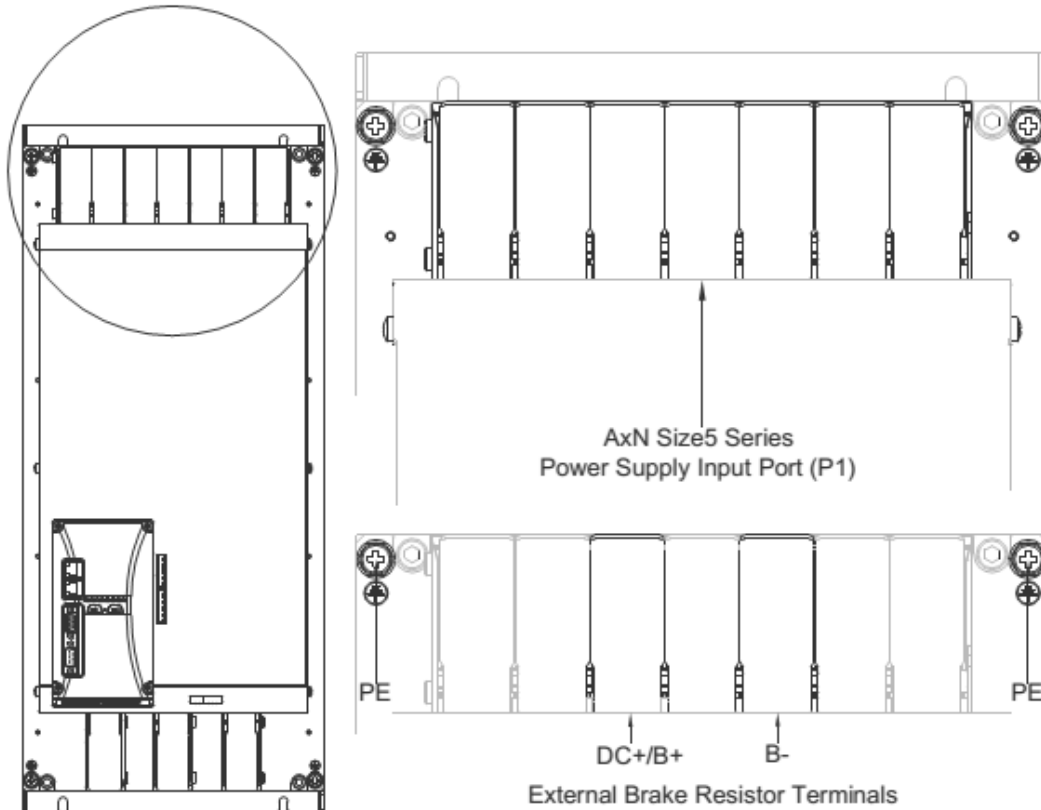

Step4: Insert Wires into Corresponding Terminals

1. Open the terminal cover and loosen the nuts on DC+/B+ and B- terminals with torque wrench and s13mm socket;
2. The circular terminal of the corresponding conductor is sheathed on the stud in the corresponding terminal (for example, the DC+-phase conductor is sheathed in the DC+/B+ terminal);
3. Then tighten the nuts on the DC+/B+ and B- terminals with a torque wrench and socket, with a tightening torque of 8.0 ~ 15.0 N.m, and close the terminal cover

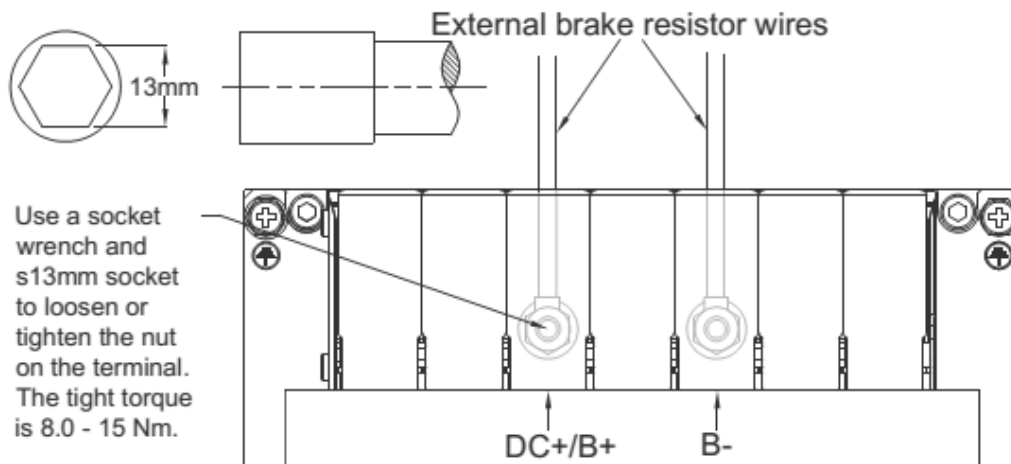

Step 5: Resistance Measurement

Use an avometer to measure the resistance between DC+/B+ and B-. Compare it with the resistance of the external resistor, if they are the same, then the external resistor has been correctly installed.

WARNING: DO NOT BYPASS THIS STEP! This step can prevent malfunctions like wires shortcut, brake resistor fault and so on.

2.4 Motor Power Output

2.4.1 Motor Power Output Cable Fabrication

Motor Power Output Cable has two sides: drive side and motor side. This manual only mention the fabrication of drive side. And the motor side fabrication differs from different motors. If the motor is manufactured by Physis Technology, our Prefabricated Motor Power Output Cables are recommended. Refer to: [Appendix: Accessories — 5.1 Prefabricated Motor Power Output Cable](#) for more details.

Step 1: Cable Selection

AxN Size5 drive must use a 4 wire cable with shield as its motor power output cable. Refer to the table below to select the appropriate cable:

| AxN Size5 | Current (A rms) | Recommended Gauge (mm ²) | Recommended Gauge (AWG) |
|---------------|-----------------|--------------------------------------|-------------------------|
| AxN 090.150.4 | 90 | 21.15 | 4 |
| AxN 110.200.4 | 110 | 26.67 | 3 |
| AxN 110.250.4 | 110 | 26.67 | 3 |
| AxN 150.300.4 | 150 | 33.62 | 2 |

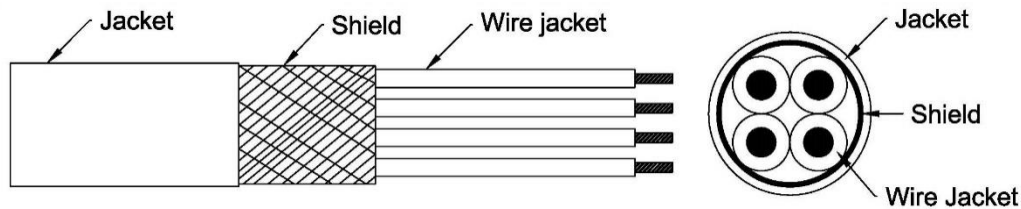

Step 2: Cable Length Measurement

Measure the distance between drive and motor then determine the suitable cable length.

Step 3: Strip Cable Outside Jacket

Strip the outside jacket of the DC power supply cable for 160mm and reveal the inside shield.

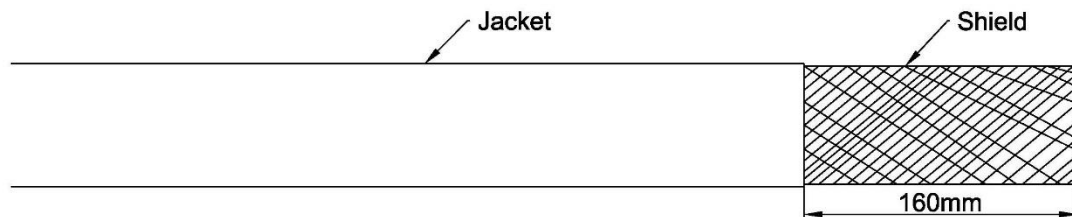

Step 4: Make Grounding Shield

Leave 65mm Shield as the grounding shield and turn it to the outside of the jacket. Then, weld a wire on the shield as the drainage line.

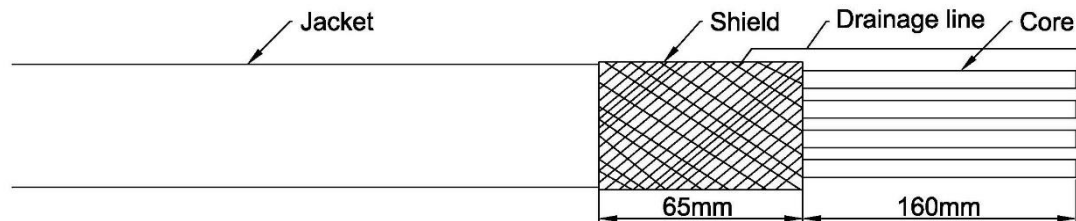

Step 5: Fix the Grounding Shield

Use a 60mm heat-shrink tube to fix the grounding shield and leave 40mm shield outside.

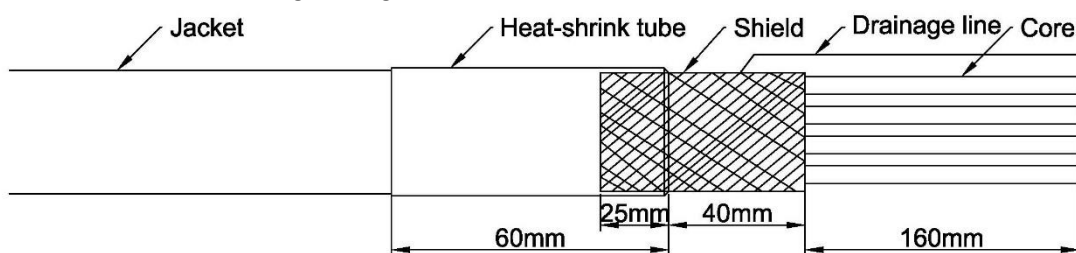

Step 6: Make the Phase Wires

Choose 3 wires of the cable as phase wires: U, V, W. Crimping pre-insulated Terminals on the wires will enhance the connection stability and simplicity between the cable and drive. AxN Size5 series drives are recommended to use the E Series Cord End Terminals manufactured by KST. Refer to the following table to select the appropriate terminal:

| AxN Size5 | Ring Terminals | d2(mm) | W(mm) | F(mm) | E(mm) | D(mm) | d1(mm) |
|---------------|----------------|--------|-------|-------|-------|-------|--------|
| AxN 090.150.4 | RNYB 22-8 | 8.4 | 16.5 | 13.5 | 24 | 13 | 7.7 |
| AxN 110.200.4 | RNYB 22-8 | 8.4 | 16.5 | 13.5 | 24 | 13 | 7.7 |
| AxN 110.250.4 | RNYB 22-8 | 8.4 | 16.5 | 13.5 | 24 | 13 | 7.7 |
| AxN 150.300.4 | RNYB 22-8 | 8.4 | 16.5 | 13.5 | 24 | 13 | 7.7 |

Strip the wires for L mm ($1 \leq L \leq E$), the recommend strip length is E/2 mm, refer to the following table to select an appropriate length:

| AxN Size5 | Strip Length (mm) | Recommended Strip Length (mm) |
|---------------|-------------------|-------------------------------|
| AxN 090.150.4 | 1 ~ 24 | 12 |
| AxN 110.200.4 | 1 ~ 24 | 12 |
| AxN 110.250.4 | 1 ~ 24 | 12 |
| AxN 150.300.4 | 1 ~ 24 | 12 |

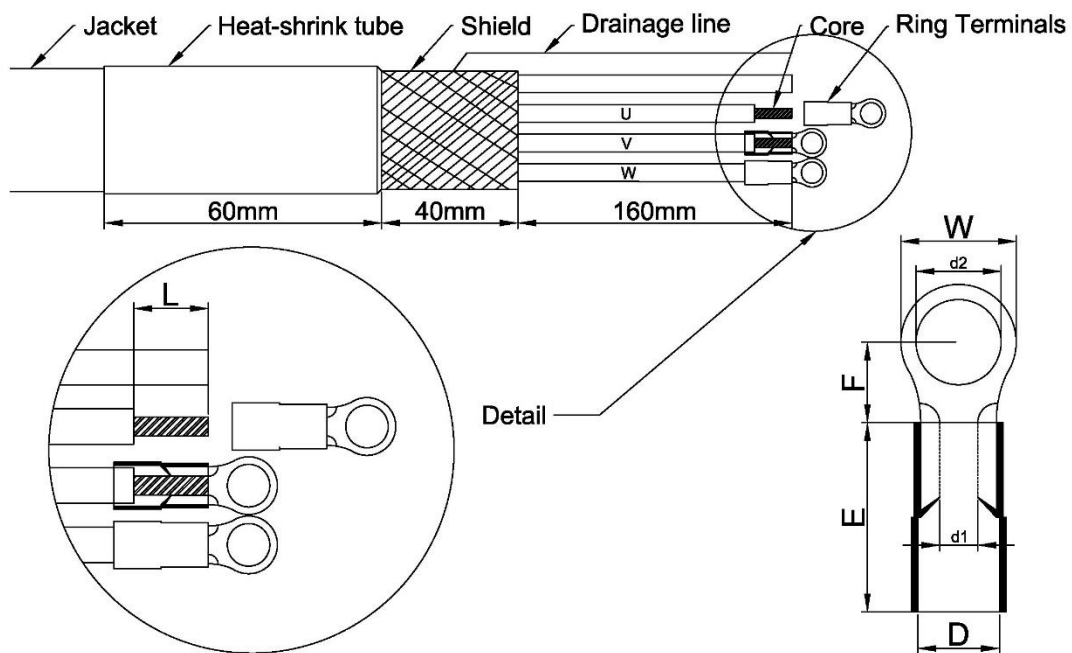

Step 7: Connect the PE wire with Shield

Use the same method to make the remaining wire as the PE wire. Then crimp the PE wire into the Ring Terminal along with the drainage line. Refer to the following table to select the appropriate terminal:

| AxN Size5 | Ring Terminals | d2 (mm) | W (mm) | F (mm) | E (mm) | D (mm) | d1 (mm) |
|---------------|----------------|---------|--------|--------|--------|--------|---------|
| AxN 090.150.4 | RNYBS22-6 | 6.4 | 12.2 | 15.1 | 24 | 13 | 7.7 |
| AxN 110.200.4 | RNYBS22-6 | 6.4 | 12.2 | 15.1 | 24 | 13 | 7.7 |
| AxN 110.250.4 | RNYBS22-6 | 6.4 | 12.2 | 15.1 | 24 | 13 | 7.7 |
| AxN 150.300.4 | RNYBS22-6 | 6.4 | 12.2 | 15.1 | 24 | 13 | 7.7 |

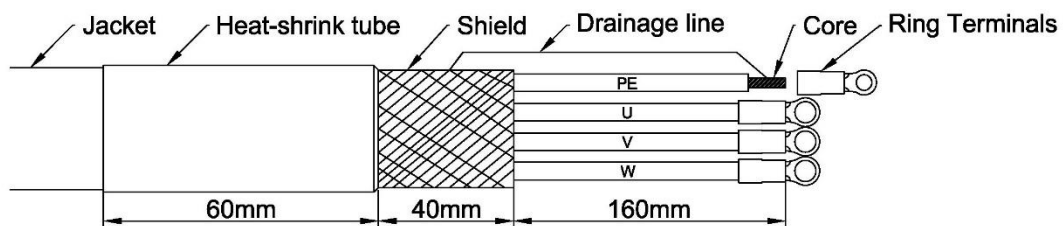

Step 8: Check and Mark

Check every wire and the connection between shield and PE wire, then label each wire.

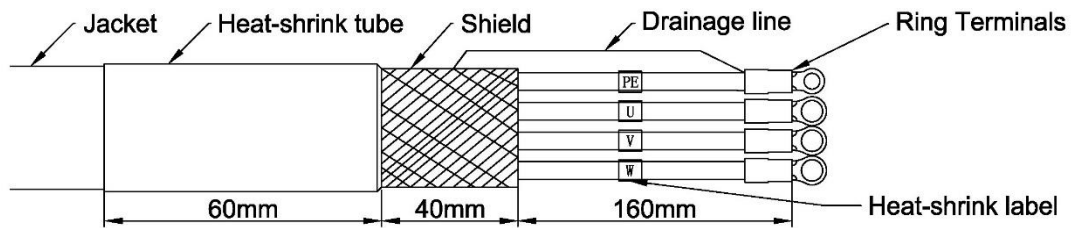

2.4.2 Motor Power Output Installation

Step 1: Find out the Motor Power Output Terminals

PE, A, B and C, these are the four terminals called Motor Power Output Terminals. AxN Size5 Drive's Motor Power Output Terminals are in the Motor Power Output Port (P2) which is on the bottom of the drive. Refer to the following figures for exact locations and terminal Assignment.

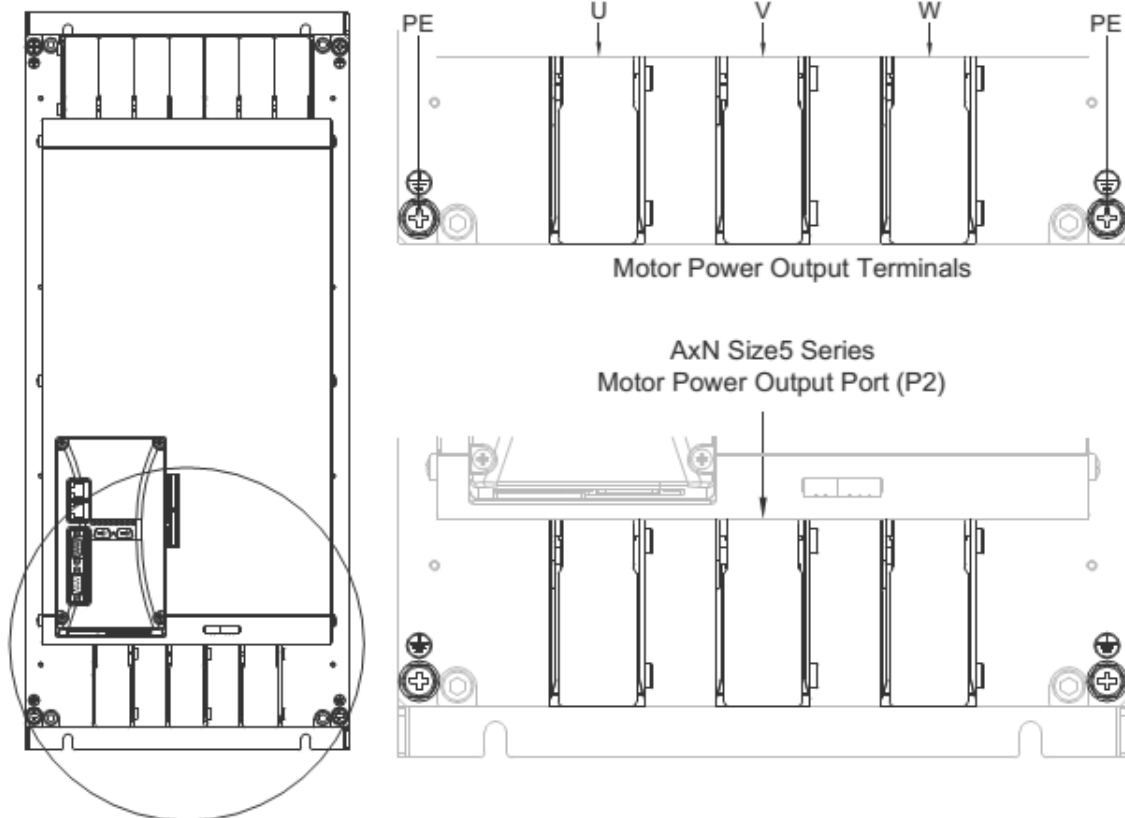

Step 2: Insert Wires into Corresponding Terminals

1. Open the terminal cover and loosen the nuts on U, V and W terminals with torque wrench and s13mm socket;
2. The circular terminal of the corresponding conductor is sheathed on the stud in the corresponding terminal (for example, the U phase conductor is sheathed in the U terminal);
3. Then tighten the nuts on the U, V and W terminals with a torque wrench and socket, with a tightening torque of 8.0 ~ 15.0 N.m, and close the terminal cover.

WARNING: The correspondence between the Motor Power Output wires and terminals should be adhered! Otherwise the motor cannot work properly!

Step 3: Install Grounding Wire

Loosen the grounding point (any one) on the machine body with an 8mm cross screwdriver, and fix the ground wire on the grounding point (PE).

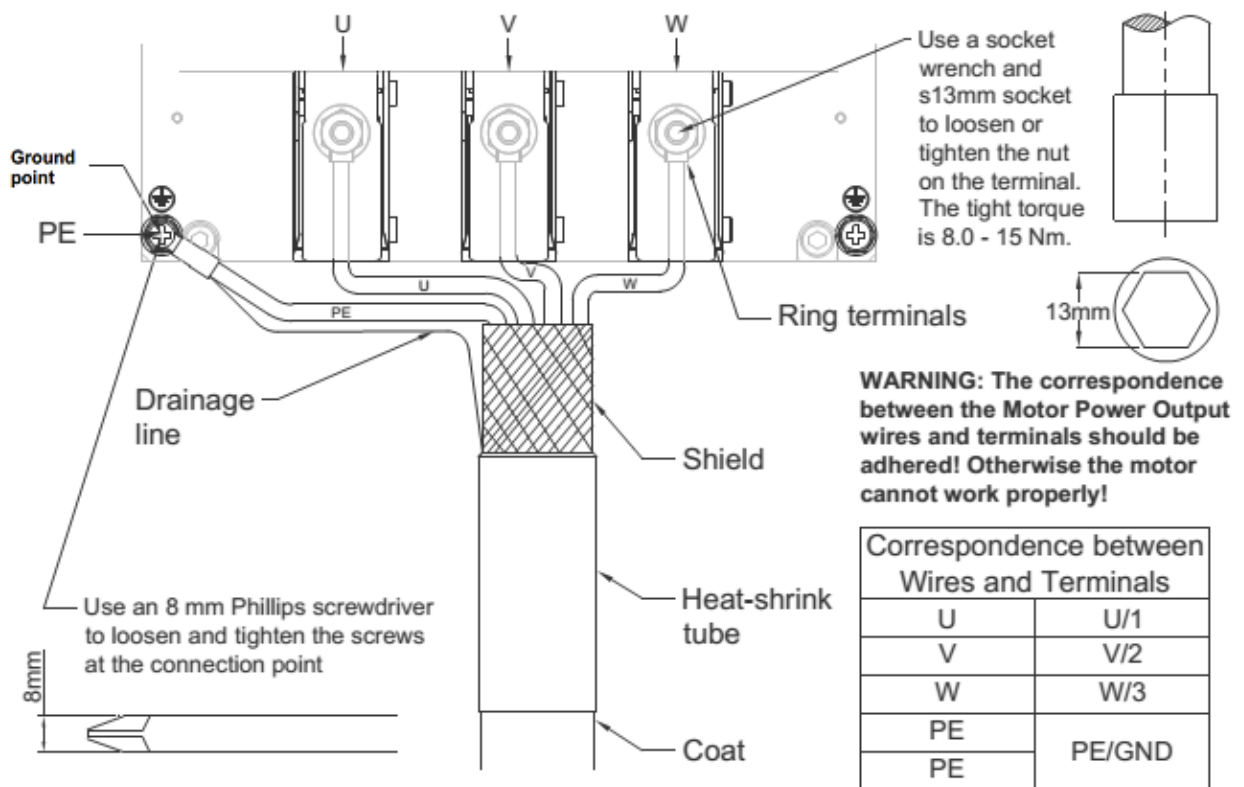

3. CONTROL CIRCUIT WIRING

3.1 Auxiliary Power Supply (AUX_Power)

3.1.1 Auxiliary Power Supply Requirement

| Main Supply | AxN Size5 |
|------------------------|---------------------|
| Voltage | 24V |
| Type | DC power |
| Fluctuation of Voltage | ±15% (20.4 ~ 27.6V) |
| Nominal Power | 192W |
| Nominal Current | 8A |

3.1.2 Auxiliary Power Supply Cable Fabrication

This manual only mention the fabrication of auxiliary power supply port on AxN drive side.

Step 1: Cable Selection

Select a 2 mm² (14 AWG) two wires cable as drive's auxiliary power supply cable.

Step 2: Cable Length Measurement

Measure the distance between drive and power supply then determine the suitable cable length.

NOTE: the distance between two devices should comply with the Installation Space Regulation of AxN Size5 Drive (Refer to [1.5 Installation Spacing](#)).

Step 3: Strip Cable Outside Jacket

Strip the outside jacket of the auxiliary power supply cable for 15mm and reveal the wires.

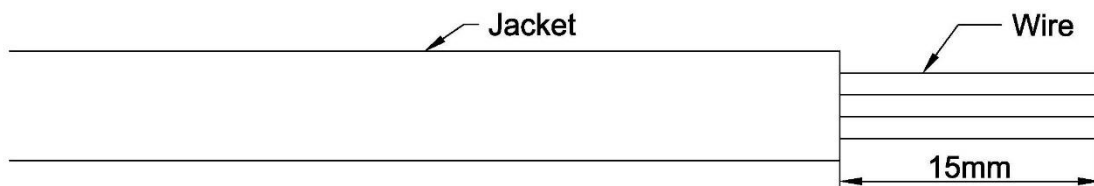

Step 4: Make DC+ Wire and DC- Wire

Mark one wire as DC+ and another as DC-, then strip wires' jacket for 5mm.

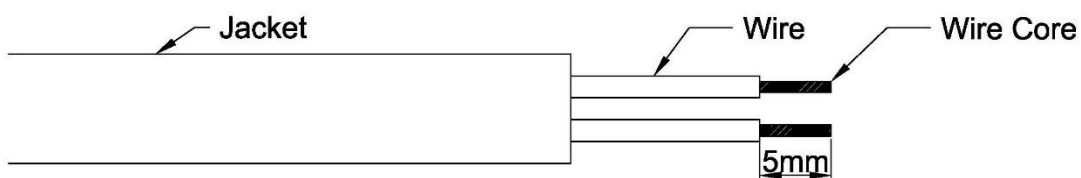

Step 5: Check and Label

Check every wire's conductivity and then label them.

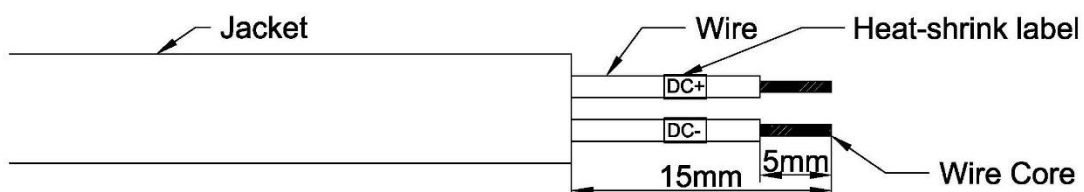

3.1.3 Auxiliary Power Supply Installation

Step 1: Check Power Supply Voltage and Power

Make sure that the auxiliary power supply's voltage is 20.4 ~ 27.6Vdc, and also can provide 8A, 192W power.

Step 2: Find out the Auxiliary Power Supply Port (AUX_Power)

AxN Series Drive's Auxiliary Power Supply Port (Male Plug, 4Pin) is on the right bottom of the drive. And a corresponding Auxiliary Power Supply Terminal (Female Plug, 4Pin) is provided in the accessories. Refer to the following figure for exact location.

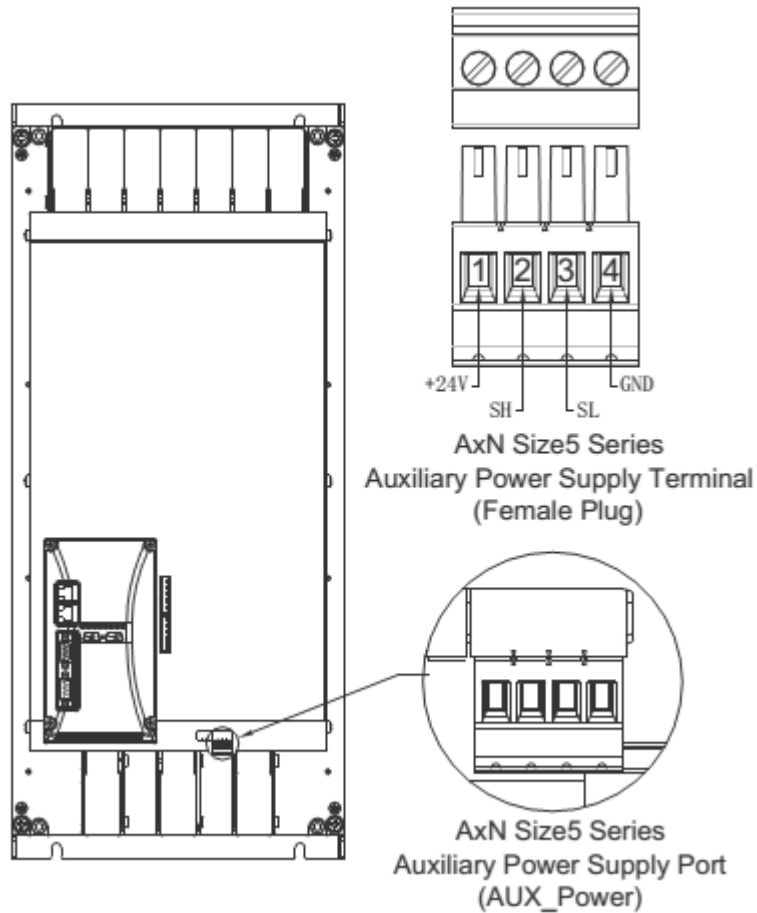

Terminal Configuration

| Pin | Name | Function | Description |
|-----|------|---|-----------------------------------|
| 1 | +24V | Control circuit power supply | 24Vdc Positive |
| 2 | SH | STO high-side power bridge power supply | 24Vdc Positive (3.2 STO Function) |
| 3 | SL | STO low-side power bridge power supply | 24Vdc Positive (3.2 STO Function) |
| 4 | GND | Reference ground | 24Vdc Negative |

Step 3: Connect the Cable to Terminal

Insert DC+ wire into terminal +24V and insert DC- wire into GND, then use a screwdriver to tight the screws on the terminals.

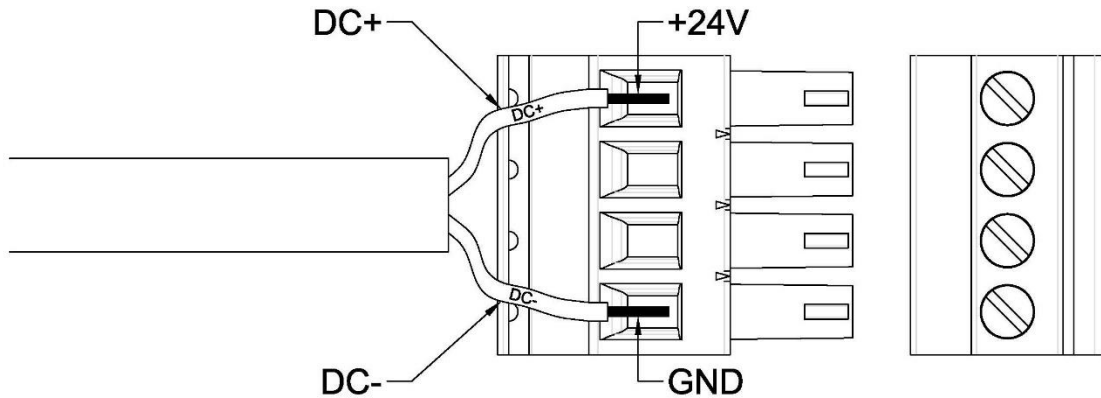

Step 4: Insert Terminal into Port

Insert the terminal along with the cable into Auxiliary Power Supply Port (AUX_Power).

3.2 STO Function

All the AxN Series Drives meet the SIL3 requirements for the safety function: Safe Torque Off (STO). There are two corresponding pins on the Auxiliary Power Supply Port: SH and SL. You can enable or disable the STO Function based on different applications with proper connections.

Enable

Apply 24 (±15%) Vdc power supply on the Pin 2: SH and Pin 3: SL with proper control system to enable the STO Function.

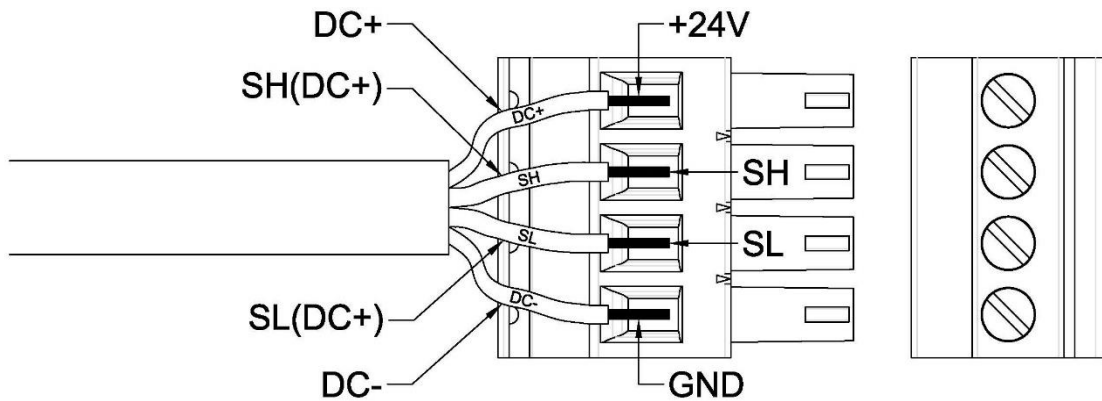
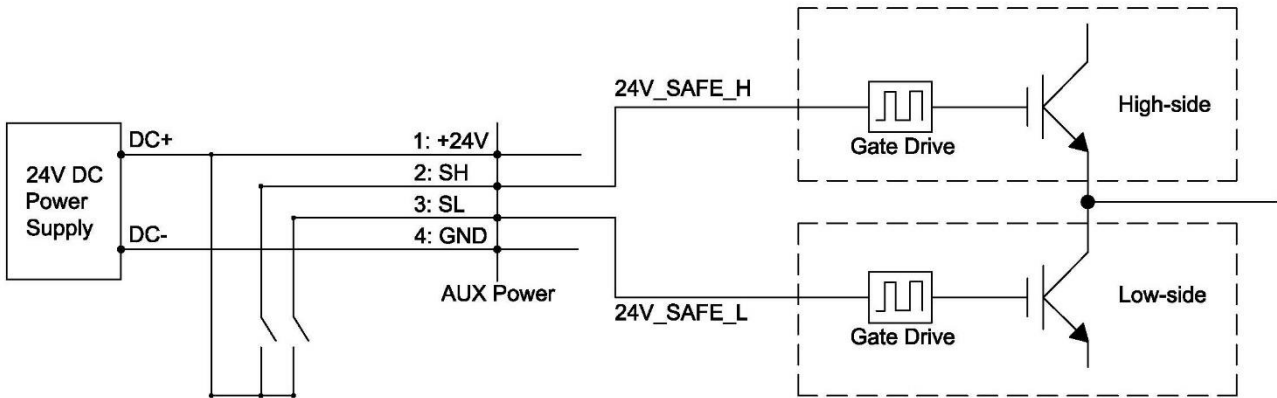

Disable

Use an insertion bridge to short cut Pin 1: +24V, Pin2: SH and Pin 3: SL to disable the STO function. The insertion bridge is in the accessory bag.

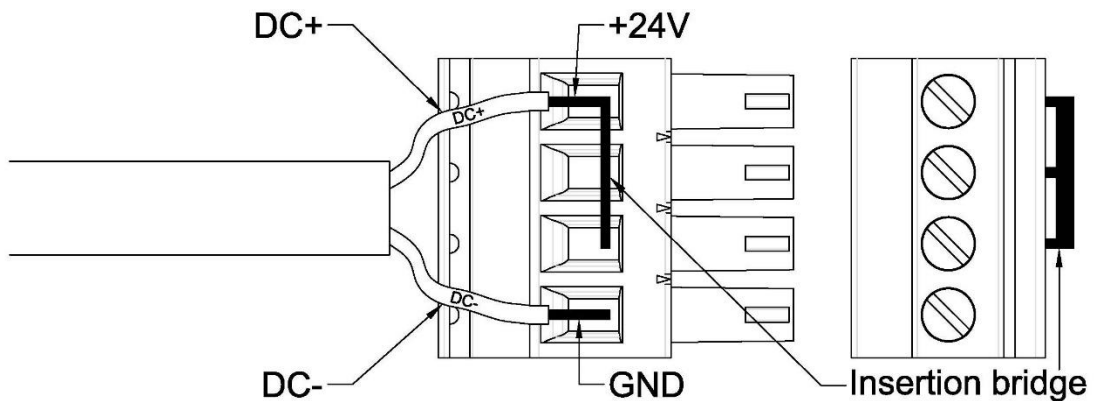
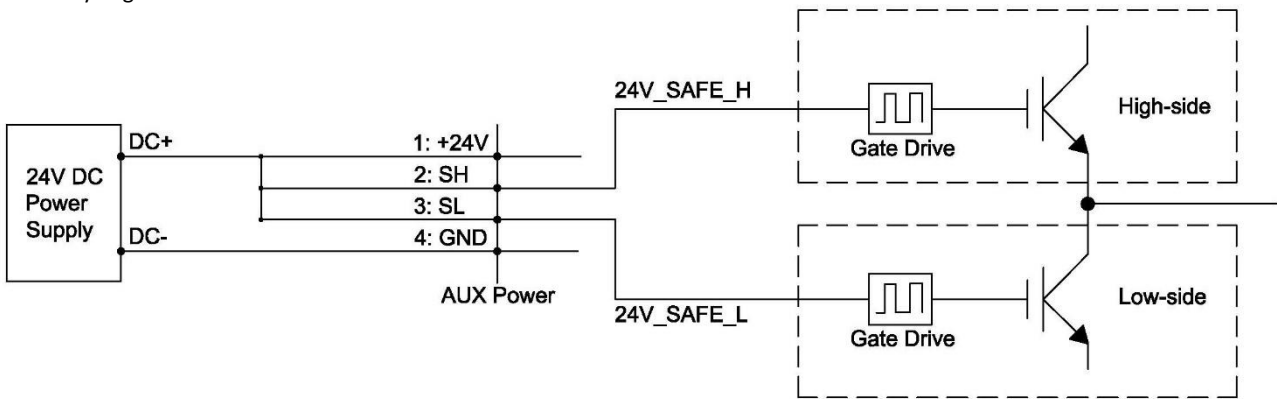

3.3 System Relay (R1)

Port Location

AxN Size5 Drive's System Relay Port (Male Plug, 3Pin) is on the right bottom of the drive. And a corresponding System Relay Terminal (Female Plug, 3Pin) is provided in the accessories. Refer to the following figures for exact location.

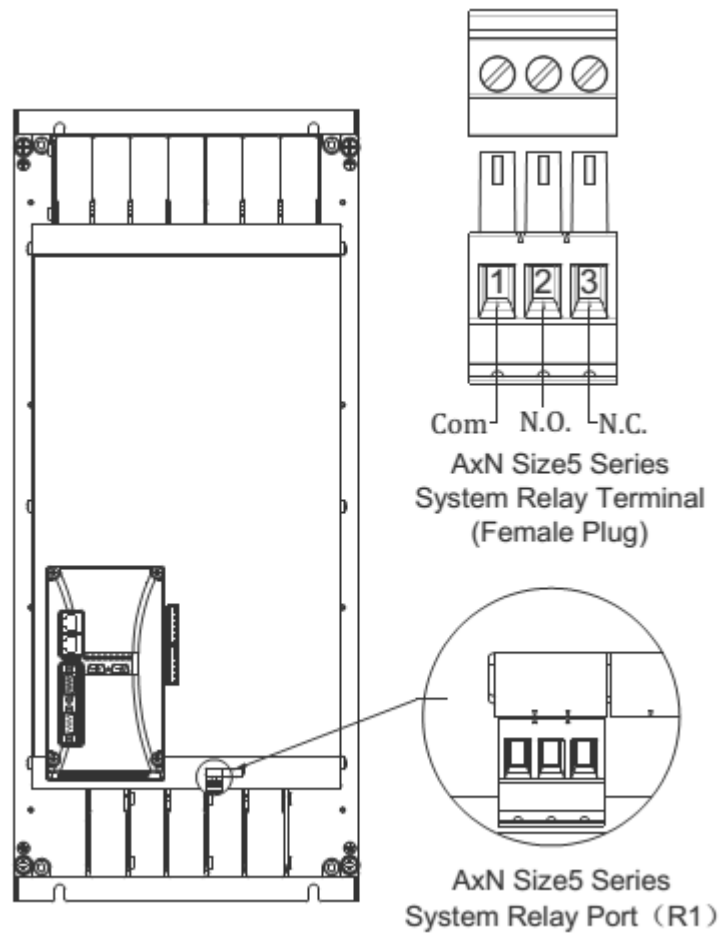

Terminal Configuration

| Pin | Name | Function | Description |
|-----|------|-------------------------------|--------------------------------------|
| 1 | Com | Common relay contact | To be used as drive system OK signal |
| 2 | N.O. | Relay normally open contact | |
| 3 | N.C. | Relay normally closed contact | |

Diagram

AxN Series Drive use a relay to indicate the status. When Drive is power off or system is not ready, the circuit is connected between N.C. (Normally Closed) and Com. In the meantime, the circuit is disconnect between N.O. (Normally Open) and Com.

When the drive is ready, N.O. connects Com and N.C. disconnects Com, illustrated as below.

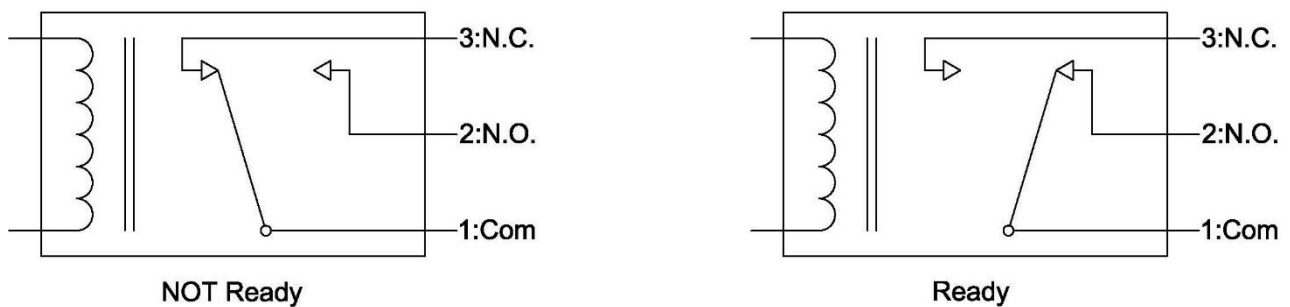

4. COMMUNICATION PORT

4.1 Overview of Communication Port Panel

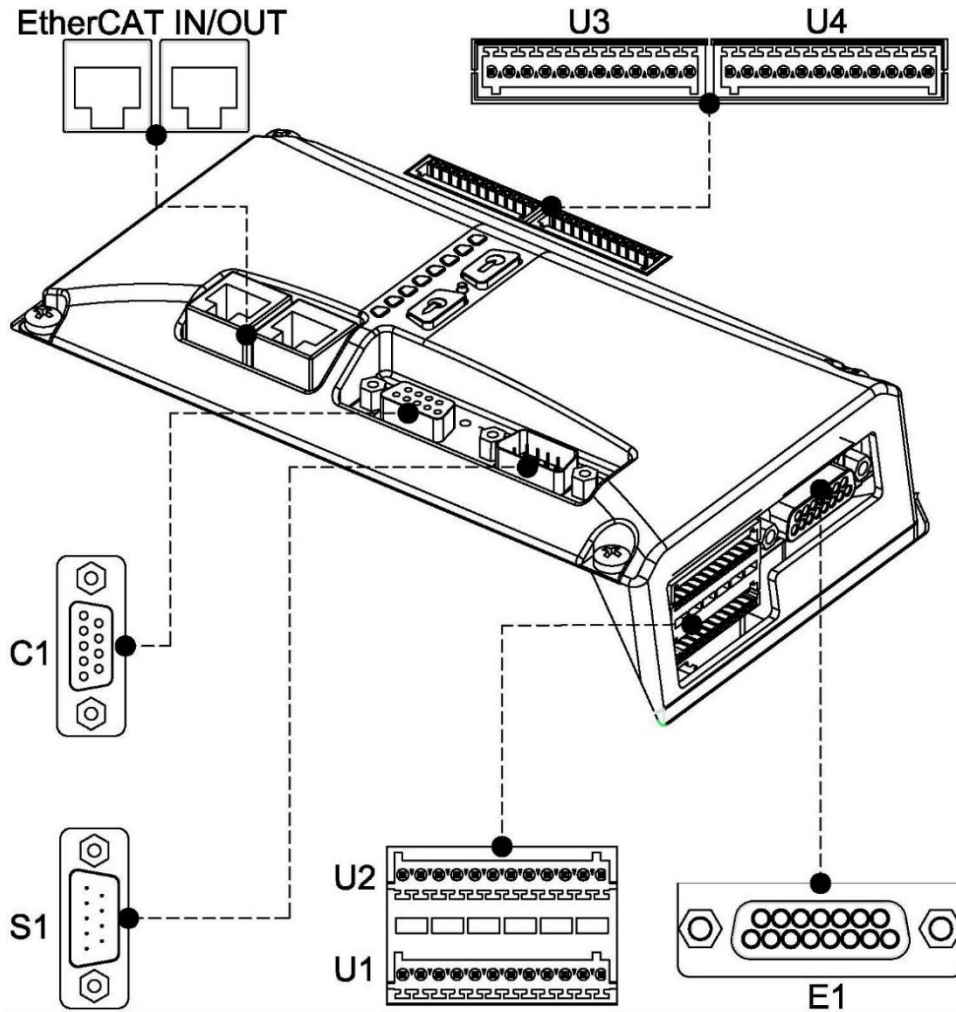

| Name | Function | Description |
|-----------------|--------------------------------------|--|
| E1 | Encoder Connector | SinCos, EnDat, Digital Incremental with Hall, Resolver and Hiperface |
| U1/U2 | User Connectors | 4 Analog Inputs, 2 Analog Outputs; 8 Digital Inputs, 4 Digital Outputs |
| S1 | Serial Bus Connector | RS232, RS422 and RS485 / Secondary CAN |
| C1 | CAN Connector | Main CAN / Auxiliary Encoder |
| EtherCAT IN/OUT | EtherCAT Connector | RJ45 100Base-TX |
| U3/U4 | Insolated User Connectors (Optional) | Insolated: 3 Analog Inputs, 2 Analog Outputs; 8 Digital Inputs, 2 Digital Outputs. Optional |

4.2 Main Encoder Port (E1)

AxN Series Drive's Main Encoder Port is used to connect motor's position sensor (encoder). AxN Series Drive can support 5 different kinds of position sensor: SinCos Encoder, EnDat Encoder, Digital Incremental Encoder with Hall, Resolver and Hiperface Encoder. Different position sensor has different pin assignment, refer to correspond section for more details.

If the motor is manufactured by Physis Technology, our Prefabricated Encoder Cables are recommended. Refer to: Appendix: Prefabricated Cable—5.2 Encoder Cable for more details.

Location

AxN Series Drive's Main Encoder Port (Female Plug, 15 Pin D-Sub) is on the right bottom of the Communication Port Panel. Refer to the following figures for exact location.

AxN Series Drive Main Encoder Port

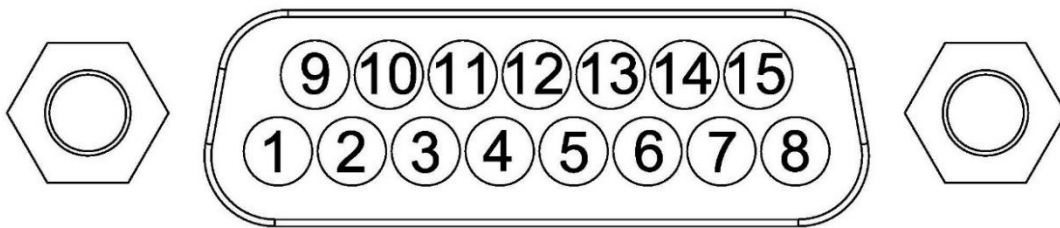
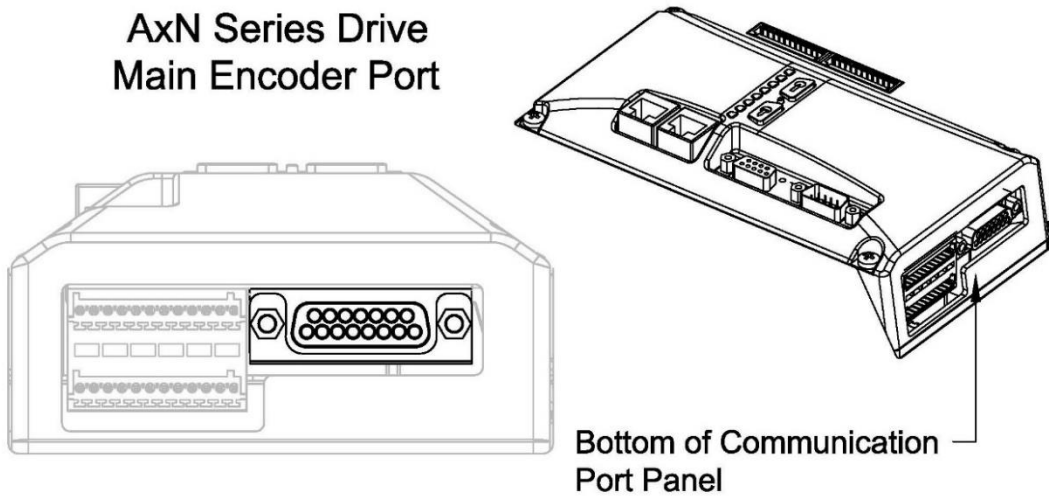

4.2.1 SinCos Encoder

| Pin | Name | Function | Signal Description |
|-----|------|-----------------------------|-------------------------|
| 1 | GND | Supply ground | Encoder ground |
| 2 | SIN+ | Encoder absolute channel | 1 Vpp differential |
| 3 | COS+ | Encoder absolute channel | 1 Vpp differential |
| 4 | COS- | Encoder absolute channel | 1 Vpp differential |
| 5 | SIN- | Encoder absolute channel | 1 Vpp differential |
| 6 | +Vcc | Encoder supply, 5Vdc | Positive supply voltage |
| 7 | A+ | Encoder incremental channel | 1 Vpp differential |
| 8 | KTY+ | Thermal sensor positive | |
| 9 | I- | Encoder index | 1 Vpp differential |
| 10 | -- | -- | -- |
| 11 | -- | -- | -- |
| 12 | A- | Encoder incremental channel | 1 Vpp differential |
| 13 | B- | Encoder incremental channel | 1 Vpp differential |
| 14 | I+ | Encoder index | 1 Vpp differential |
| 15 | B+ | Encoder Incremental channel | 1 Vpp differential |

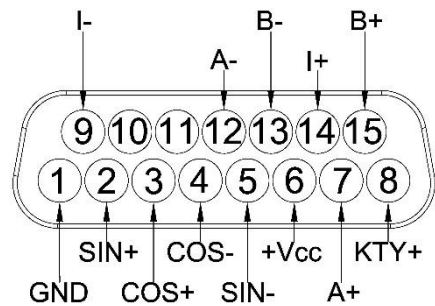

4.2.2 EnDat Encoder

| Pin | Name | Function | Signal Description |
|-----|--------|-------------------------|-------------------------|
| 1 | GND | Supply ground | Encoder ground |
| 2 | -- | -- | -- |
| 3 | CLOCK+ | EnDat clock | TTL |
| 4 | CLOCK- | EnDat clock | TTL |
| 5 | -- | -- | -- |
| 6 | +Vcc | Encoder supply, 8Vdc | Positive supply voltage |
| 7 | -- | -- | -- |
| 8 | KTY+ | Thermal sensor positive | |
| 9 | DATA- | EnDat data | TTL |
| 10 | -- | -- | -- |
| 11 | -- | -- | -- |
| 12 | -- | -- | -- |
| 13 | -- | -- | -- |
| 14 | DATA+ | EnDat data | TTL |
| 15 | -- | -- | -- |

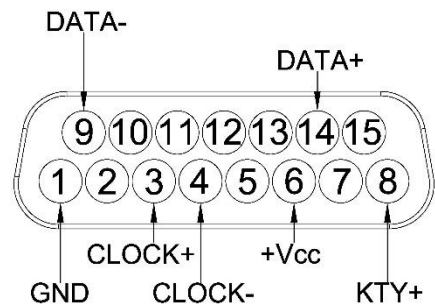

4.2.3 Digital Incremental Encoder with Hall

| Pin | Name | Function | Signal Description |
|-----|------|-----------------------------|-------------------------|
| 1 | GND | Supply ground | Encoder ground |
| 2 | -- | -- | -- |
| 3 | H1 | Hall sensor | TTL |
| 4 | H2 | Hall sensor | TTL |
| 5 | H3 | Hall sensor | TTL |
| 6 | +Vcc | Encoder supply, 8Vdc | Positive supply voltage |
| 7 | B+ | Encoder incremental channel | TTL |
| 8 | KTY+ | Thermal sensor positive | |
| 9 | I- | Encoder index | TTL |
| 10 | -- | -- | -- |
| 11 | -- | -- | -- |
| 12 | B- | Encoder incremental channel | TTL |
| 13 | A- | Encoder incremental channel | TTL |
| 14 | I+ | Encoder index | TTL |
| 15 | A+ | Encoder incremental channel | TTL |

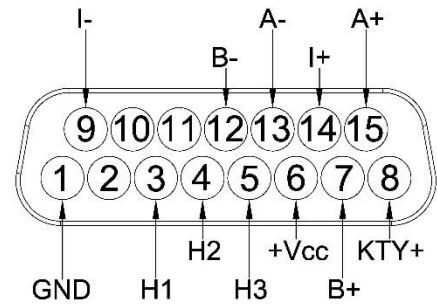

4.2.4 Resolver

| Pin | Name | Function | Signal Description |
|-----|--------|-------------------------|----------------------|
| 1 | -- | -- | -- |
| 2 | SIN+ | Absolute channel | Differential signal |
| 3 | COS+ | Absolute channel | Differential signal |
| 4 | COS- | Absolute channel | Differential signal |
| 5 | SIN- | Absolute channel | Differential signal |
| 6 | -- | -- | -- |
| 7 | -- | -- | -- |
| 8 | KTY+ | Thermal sensor positive | |
| 9 | -- | -- | -- |
| 10 | RESEX+ | Resolver energising + | 8kHz sinusoidal wave |
| 11 | RESEX- | Resolver energising - | 8kHz sinusoidal wave |
| 12 | -- | -- | -- |
| 13 | -- | -- | -- |
| 14 | -- | -- | -- |
| 15 | -- | -- | -- |

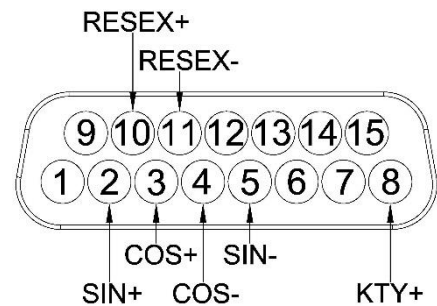

4.2.5 Hiperface Encoder

| Pin | Name | Function | Signal Description |
|-----|-------|--------------------------|-------------------------|
| 1 | GND | Supply ground | Encoder ground |
| 2 | -- | -- | -- |
| 3 | -- | -- | -- |
| 4 | -- | -- | -- |
| 5 | -- | -- | -- |
| 6 | +Vcc | Encoder supply, 8Vdc | Positive supply voltage |
| 7 | COS+ | Process data channel | TTL |
| 8 | KTY+ | Thermal sensor positive | |
| 9 | DATA- | RS-485 parameter channel | TTL |
| 10 | -- | -- | -- |
| 11 | -- | -- | -- |
| 12 | COS- | Process data channel | TTL |
| 13 | SIN- | Process data channel | TTL |
| 14 | DATA+ | RS-485 parameter channel | TTL |
| 15 | SIN+ | Process data channel | TTL |

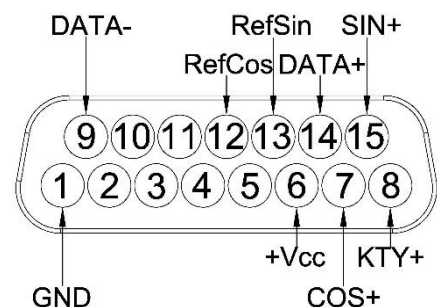

4.3 S1 - Serial Bus Port

AxN Series Drive's Serial Bus Port (S1) supports RS-232, RS-422, RS-485 and CAN protocol. But only one communication interface can be used at a time.

Location

AxN Series Drive's Serial Bus Port (Male Plug, 9 Pin D-Sub) is on the downside of drive's communication port panel. Refer to the following figures for exact location.

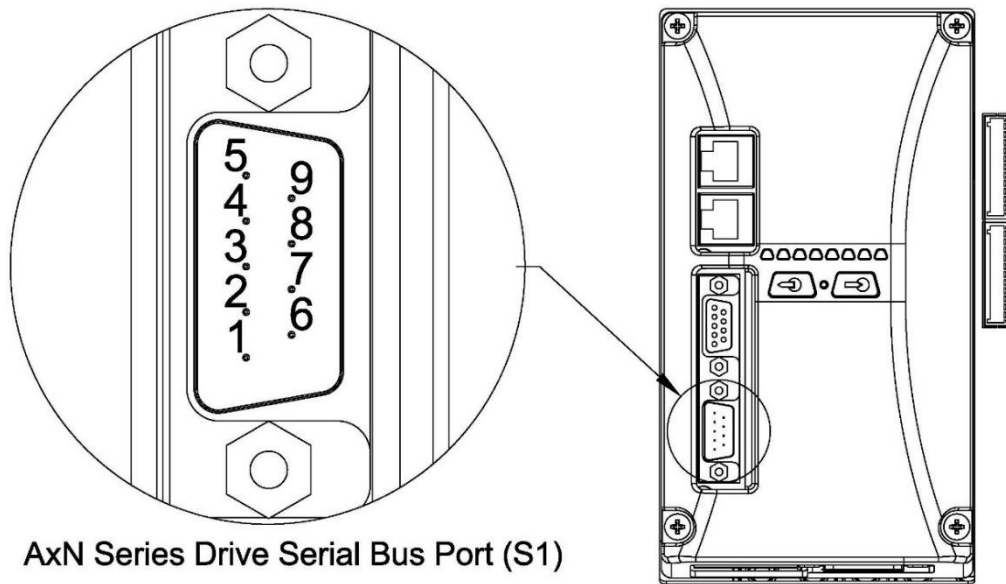

AxN Series Drive Serial Bus Port (S1)

4.3.1 RS-232

Pin Assignment

| Pin | Standard RS-232 | AxN RS-232 | Function |
|-----|-----------------|------------|---------------------|
| 1 | DCD | -- | Data Carrier Detect |
| 2 | RXD | RXD | Received Data |
| 3 | TXD | TXD | Transmitted Data |
| 4 | DTR | DTR | Data Terminal Ready |
| 5 | GND | GND | Common Ground |
| 6 | DSR | DSR | Data Set Ready |
| 7 | RTS | RTS | Request To Send |
| 8 | CTS | CTS | Clear To Send |
| 9 | RI | -- | Ring Indicator |

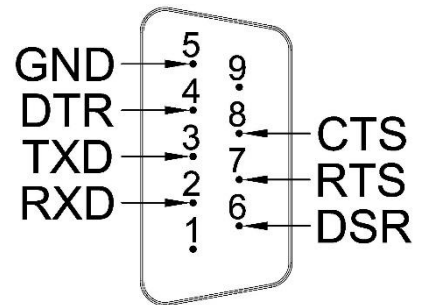

Notes:

- RS-232 devices may be classified as Data Terminal Equipment (DTE) or Data Communication Equipment (DCE); this defines at each device which wires will be sending and receiving each signal. AxN Series Drive is a Data Communication Equipment (DCE), and a controller or a computer is a Data Terminal Equipment (DTE).
- The signal voltage is $\pm 12V$, and the max current of DTR (Pin4) is 100mA.

4.3.1.1 Minimal "3-wire" Connection

A minimal "3-wire" RS-232 connection consisting only of transmit data, receive data, and ground, is commonly used when the full facilities of RS-232 are not required. And it also the minimal connection requirement of Cockpit communication with AxN Series Drive.

Connection table

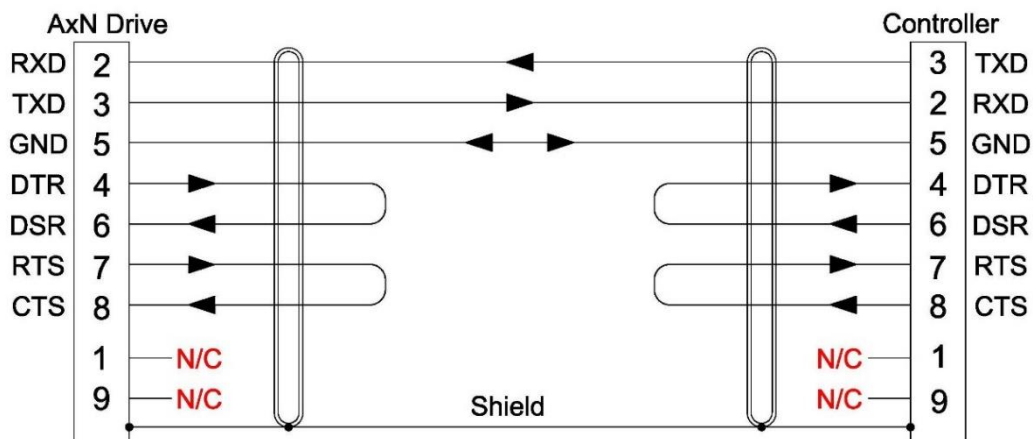

- 1) N/C—No Connection;
- 2) Connector back shell shielded 360°(Both ends);
- 3) ● means that the shield or cable should connect to connectors.

Connection diagram

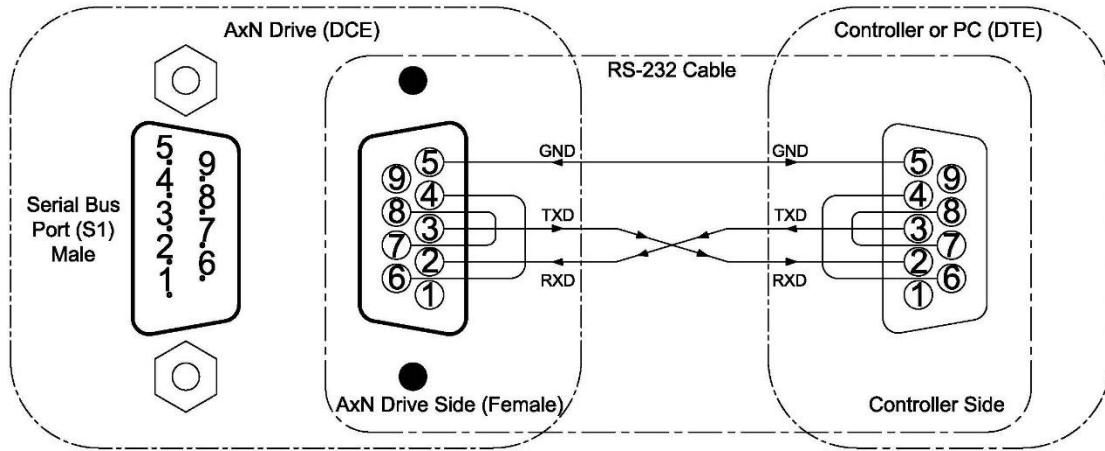

4.3.1.2 Maximal "7-wire" Connection

When the controller has a full facilities of RS-232, "7-wire" connection is the maximal connection which AxN series drive can support. **NOTE:** Do **NOT** use "9-wire" connection, AxN series drive do not support DCD and RI function.

Connection table

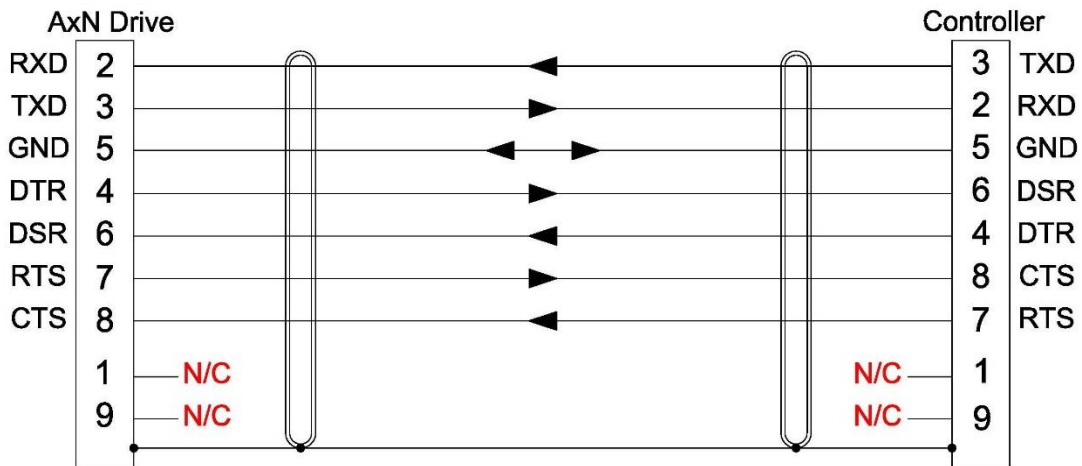

- 1) N/C—No Connection;
- 2) Connector back shell shielded 360°(Both ends);
- 3) ● means that the shield or cable should connect to connectors.

Connection diagram

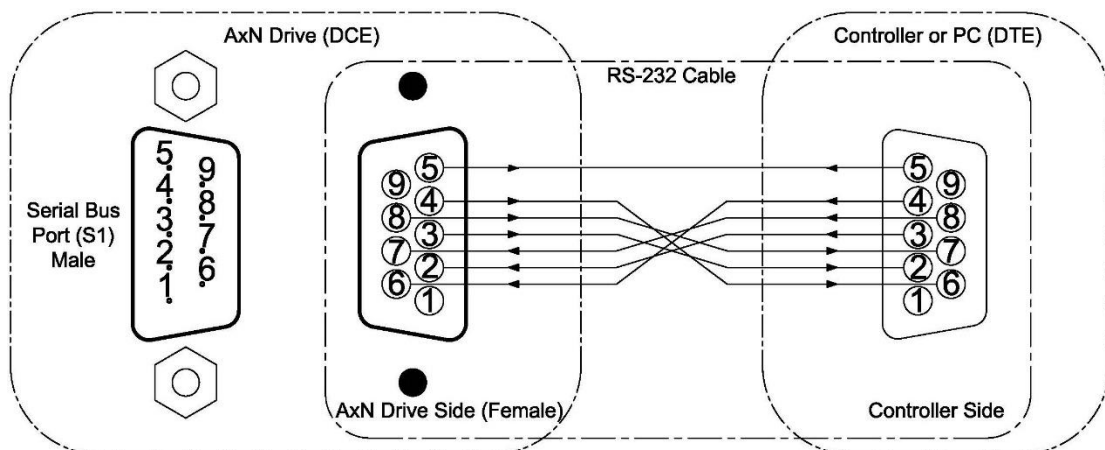

4.3.2 RS422/485

Pin Assignment

| Pin | RS-422 | RS-485 | Function |
|-----|--------|----------|-------------------|
| 1 | -- | -- | -- |
| 2 | RX+ | RX+(LN+) | Receive Data + |
| 3 | TX- | TX-(LN-) | Transmit Data - |
| 4 | -- | -- | -- |
| 5 | GND | GND | Ground connection |
| 6 | -- | -- | -- |
| 7 | TX+ | TX+(LN+) | Transmit Data + |
| 8 | RX- | RX-(LN-) | Receive Data - |
| 9 | -- | -- | -- |

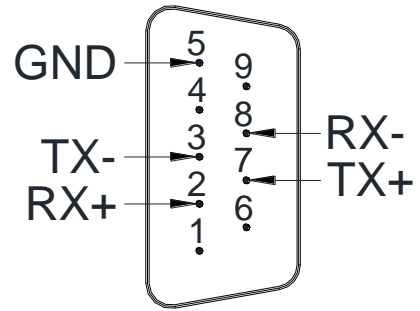

RS-422 Connection Table

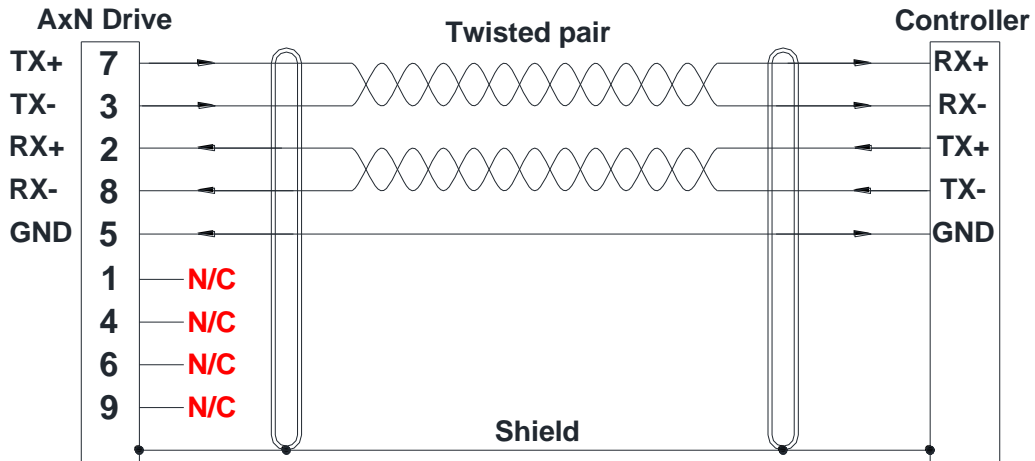

- 1) N/C—No Connection;
- 2) Connector back shell shielded 360°(Both ends);
- 3) ● means that the shield or cable should connect to connectors.

RS-485 Connection Table

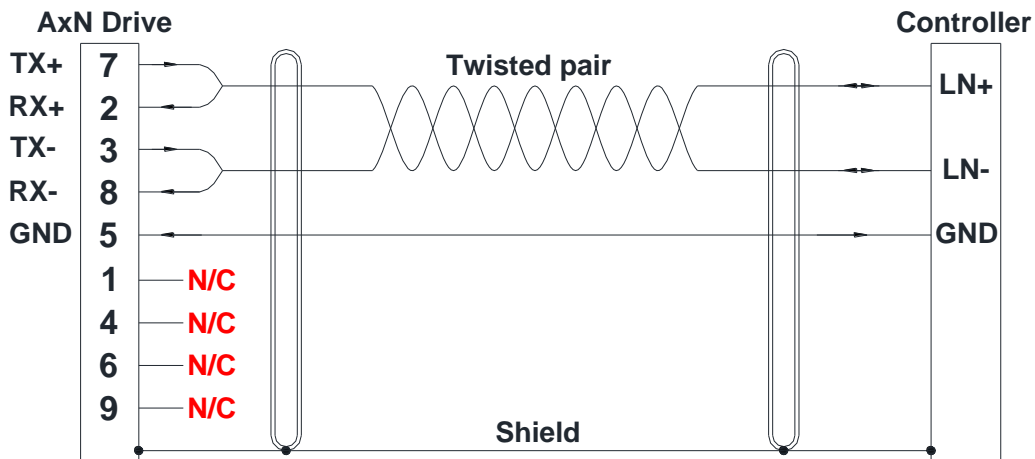

- 4) N/C—No Connection;
- 5) Connector back shell shielded 360°(Both ends);
- 6) ● means that the shield or cable should connect to connectors.

4.3.3 Auxiliary CAN

AxN Series Drive supports CANopen protocol and has two independent CAN controller. The auxiliary CAN controller links to the S1 connector.

Pin Assignment

| Pin | CANopen | Function |
|-----|---------|--------------------------------|
| 1 | CAN_H | CAN_H bus line (dominant high) |
| 2 | -- | -- |
| 3 | -- | -- |
| 4 | -- | -- |
| 5 | GND | Ground connection |
| 6 | -- | -- |
| 7 | -- | -- |
| 8 | -- | -- |
| 9 | CAN_L | CAN_L bus line (dominant low) |

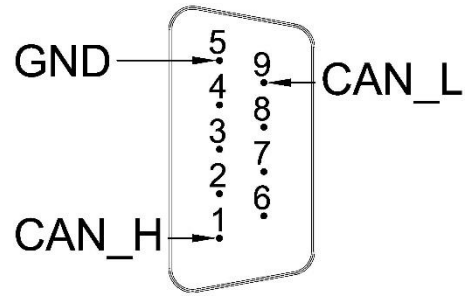

Note: CANopen pin assignment on S1 connector does NOT meet CiA 102 Standard.

Connection Table

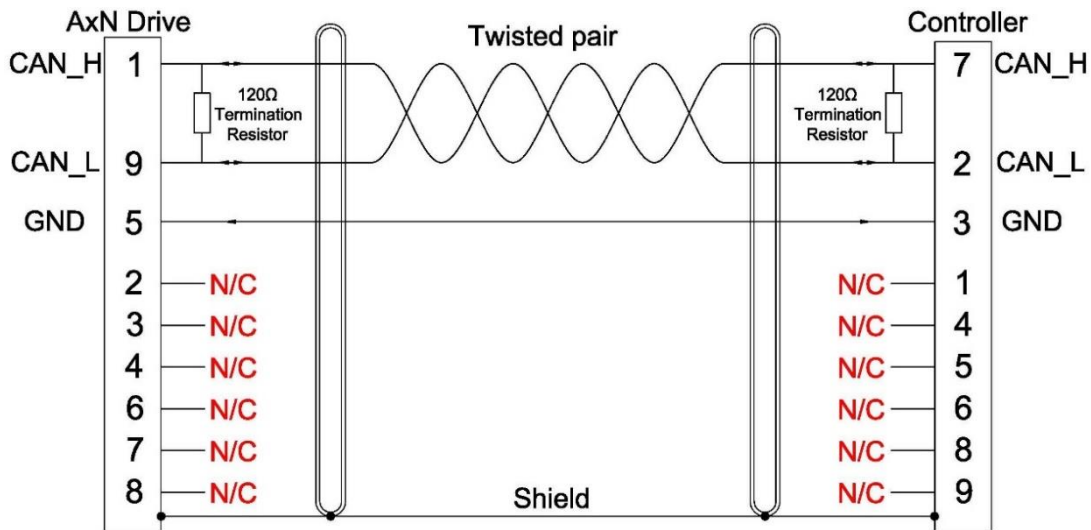

- 1) N/C—No Connection;
- 2) Connector back shell shielded 360°(Both ends);
- 3) ● means that the shield or cable should connect to connectors.

Connection diagram

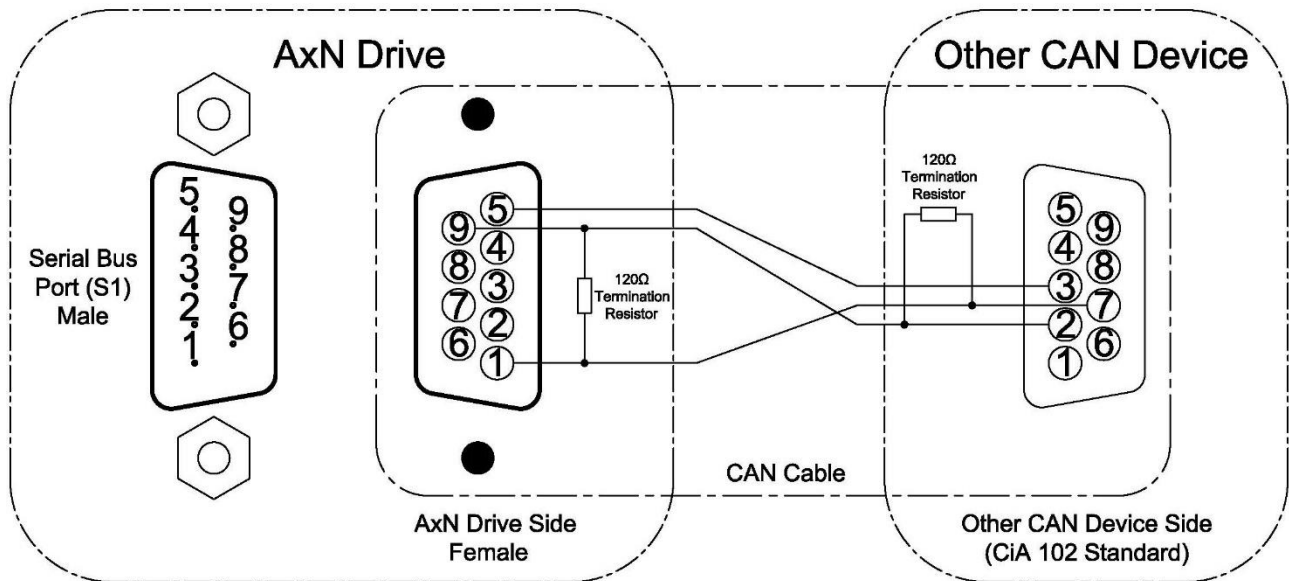

Note: Only the first and the last CAN node device should use a 120Ω terminal resistor.

4.4 C1 - Main CAN Port

AxN Series Drive's Main CAN Port (C1) connects to the main CAN controller inside the AxN drive. It the default CAN network port of AxN drive. Moreover, C1 port can also be used as Auxiliary Encoder Port.

Location

AxN Series Drive's Main CAN Port (Female Plug, 9 Pin D-Sub) is on the middle side of drive's communication port panel. Refer to the following figures for exact location.

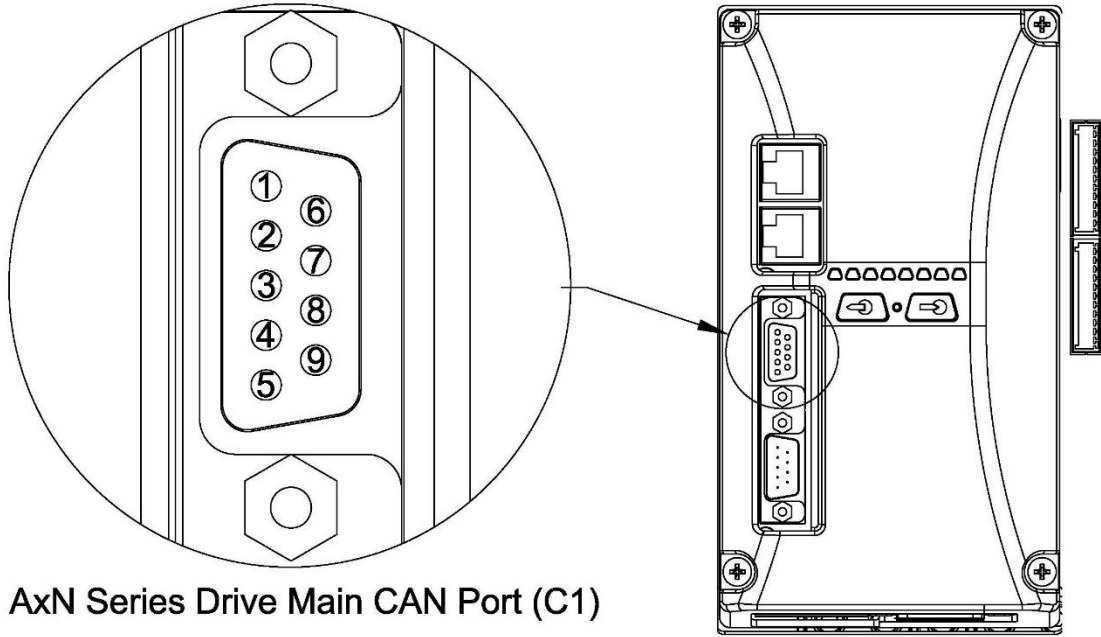

AxN Series Drive Main CAN Port (C1)

4.4.1 Main CAN

AxN Series Drive supports CANopen protocol and has two independent CAN controller. The main CAN controller links to the C1 connector.

Pin Assignment

| Pin | CANopen | Function |
|-----|---------|--------------------------------|
| 1 | --- | --- |
| 2 | CAN_L | CAN_L bus line (dominant low) |
| 3 | GND | Ground connection |
| 4 | --- | --- |
| 5 | --- | --- |
| 6 | --- | --- |
| 7 | CAN_H | CAN_H bus line (dominant high) |
| 8 | --- | --- |
| 9 | --- | --- |

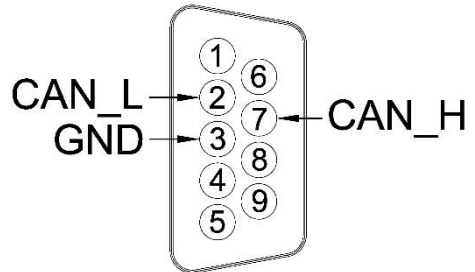

Connection Table

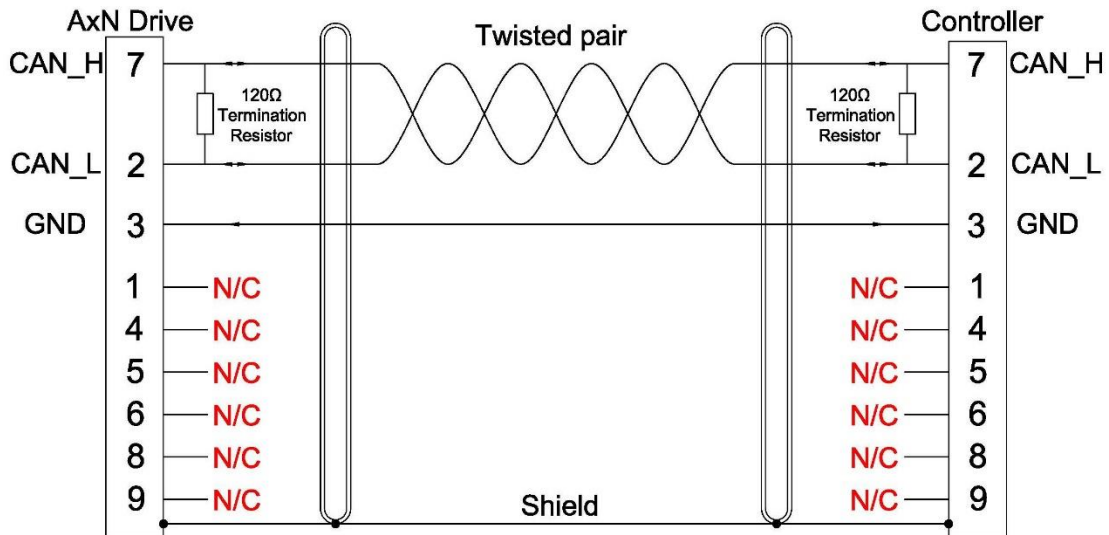

- 1) N/C—No Connection;
- 2) Connector back shell shielded 360°(Both ends);
- 3) ● means that the shield or cable should connect to connectors.

Connection diagram

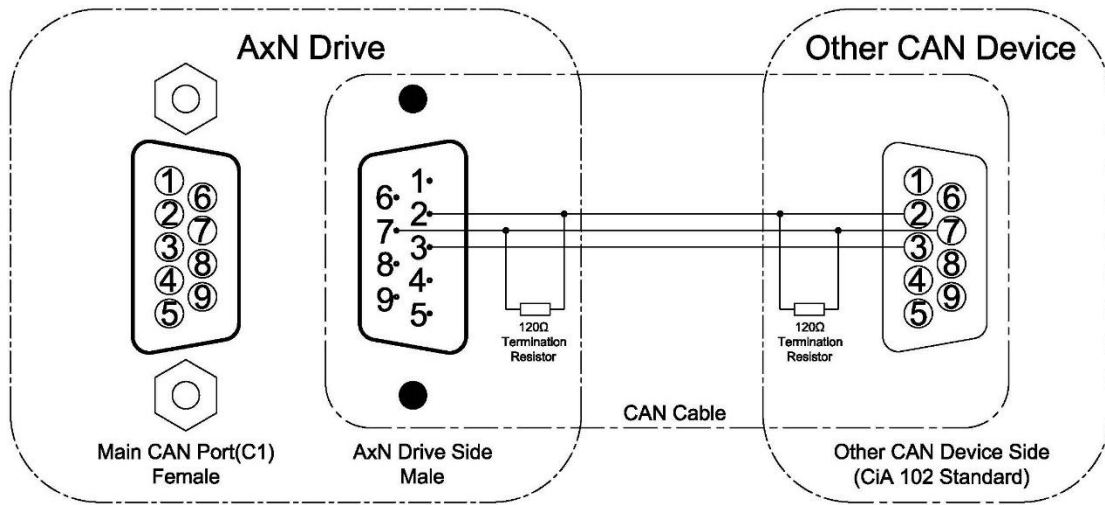

Note: Only the first and the last CAN node device should use a 120Ω terminal resistor.

4.4.2 Auxiliary Encoder

C1 port is also the Auxiliary Encoder Port. It supports Endat Encoder IN, Incremental Encoder IN and Simulated Incremental Encoder OUT. The output voltage of Simulated Incremental Encoder is 0 ~ 3.3V.

Endat Encoder (IN)

| Pin | Name | Function |
|-----|--------|-------------------|
| 1 | DATA+ | Endat Data |
| 2 | --- | --- |
| 3 | GND | Ground connection |
| 4 | CLOCK- | Endat Clock |
| 5 | --- | --- |
| 6 | DATA- | Endat Data |
| 7 | --- | --- |
| 8 | CLOCK+ | Endat Clock |
| 9 | --- | --- |

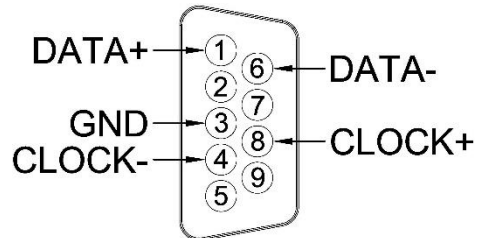

Incremental Encoder (IN/OUT)

| Pin | Name | Function |
|-----|------|-----------------------------|
| 1 | B+ | Encoder incremental channel |
| 2 | --- | --- |
| 3 | GND | Ground connection |
| 4 | A- | Encoder incremental channel |
| 5 | I- | Encoder index |
| 6 | B- | Encoder incremental channel |
| 7 | --- | --- |
| 8 | A+ | Encoder incremental channel |
| 9 | I+ | Encoder index |

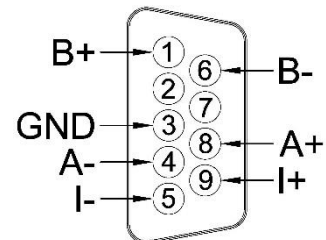

4.5 EtherCAT IN/OUT - EtherCAT Port

AxN Series Drive supports EtherCAT fieldbus protocol. And can be connected to an EtherCAT network through two connectors: EtherCAT IN and EtherCAT OUT.

Port Location

AxN Series Drive’s EtherCAT Port is on the upside of drive’s communication port panel, formed by two RJ45 100Base-TX female plug. Refer to the following figure for exact location.

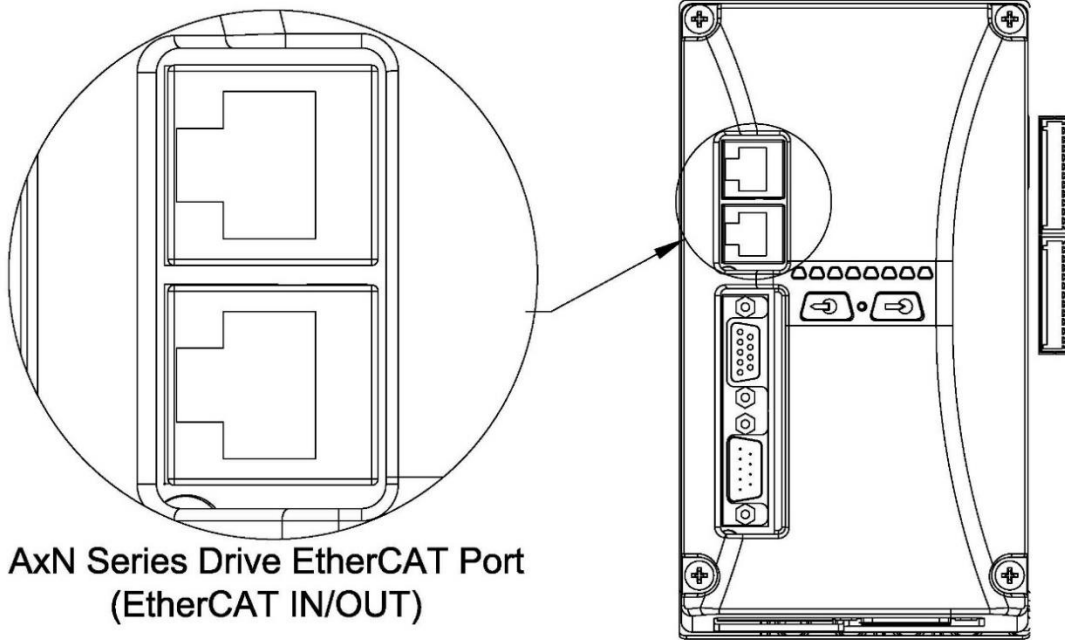

**AxN Series Drive EtherCAT Port
(EtherCAT IN/OUT)**

Pin Assignment

| Pin | Name | Function |
|-----|------|-----------------|
| 1 | TX + | Transmit Data + |
| 2 | TX - | Transmit Data - |
| 3 | RX + | Receive Data + |
| 4 | --- | --- |
| 5 | --- | --- |
| 6 | RX - | Receive Data - |
| 7 | --- | --- |
| 8 | --- | --- |

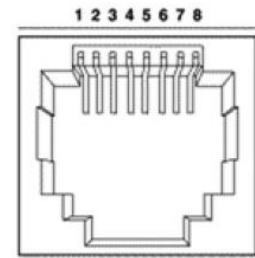

4.6 U1/U2 - User Connectors

Port Location

AxN Series Drive's User Connectors (Male Plug, 2×12 pin) are on the left bottom of the Communication Port Panel. Refer to the following figure for exact location.

**AxN Series Drive
User Connectors (U1/U2)**

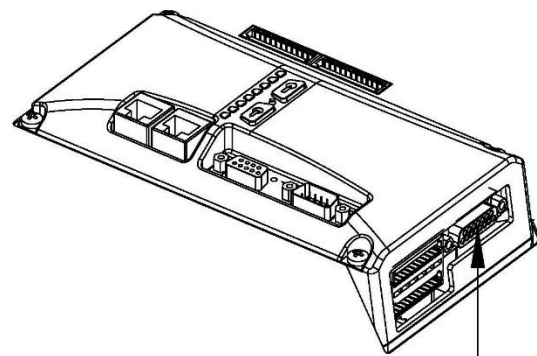
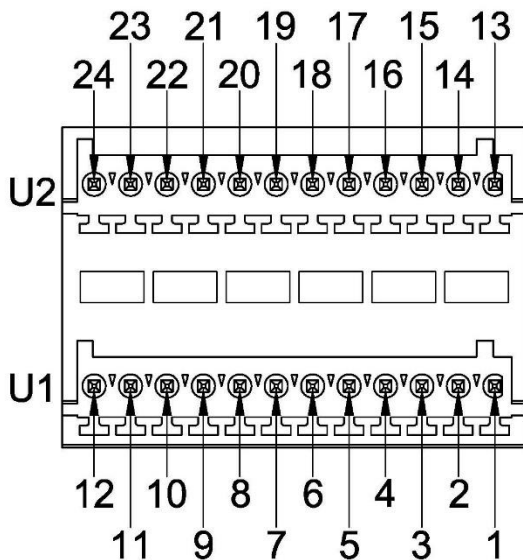

Bottom of Communication Port Panel

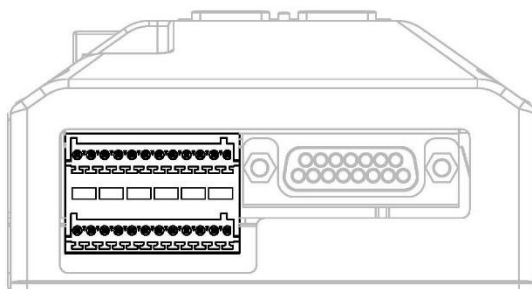

Diagram

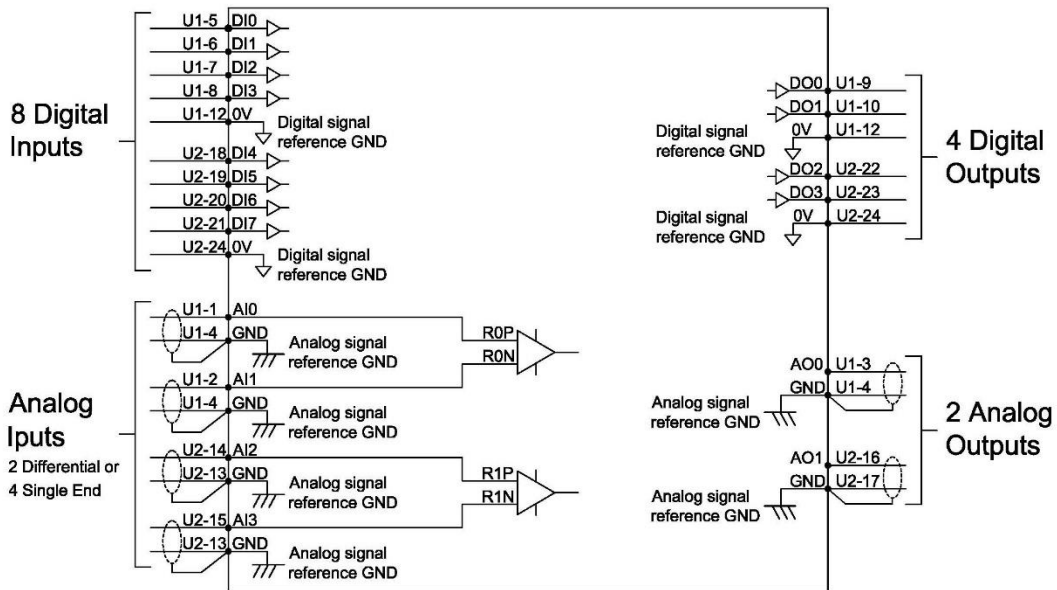

NOTE: All analog signal reference GND are the same, and all digital signal reference GND are the same.

Pin Assignment

User Connector U1

| Pin | Name | Function | Signal Description |
|-----|-----------|-----------------------------|---|
| 1 | R0P (AI0) | Programmable analog input | ±10V, Zin=10KΩ, able to switch between differential mode and single end mode ⁽¹⁾ |
| 2 | R0N (AI1) | Programmable analog input | ±10V, Zin=10KΩ, able to switch between differential mode and single end mode ⁽¹⁾ |
| 3 | AO0 | Programmable analog output | 0 ~ 10V f.s., 30 mA |
| 4 | GND | Analog reference ground | Analog signals reference |
| 5 | DI0 | Programmable digital input | 6.6 kΩ to ground, 20-30 V |
| 6 | DI1 | Programmable digital input | 6.6 kΩ to ground, 20-30 V |
| 7 | DI2 | Programmable digital input | 6.6 kΩ to ground, 20-30 V |
| 8 | DI3 | Programmable digital input | 6.6 kΩ to ground, 20-30 V |
| 9 | DO0 | Programmable digital output | PNP open collector, 24 V, 100mA max |
| 10 | DO1 | Programmable digital output | PNP open collector, 24 V, 100mA max |
| 11 | N\C | Undefined | No connection |
| 12 | COM | Digital signal reference | Digital signal reference |

User Connector U2

| Pin | Name | Function | Signal Description |
|-----|-----------|-----------------------------|---|
| 13 | GND | Analog reference ground | Analog signals reference |
| 14 | R1P (AI2) | Programmable analog input | ±10V, Zin=10KΩ, able to switch between differential mode and single end mode ⁽¹⁾ |
| 15 | R1N (AI3) | Programmable analog input | ±10V, Zin=10KΩ, able to switch between differential mode and single end mode ⁽¹⁾ |
| 16 | AO1 | Programmable analog output | 0 ~ 10V f.s., 30 mA |
| 17 | GND | Analog reference ground | Analog signals reference |
| 18 | DI4 | Programmable digital input | 6.6 kΩ to ground, 20-30 V |
| 19 | DI5 | Programmable digital input | 6.6 kΩ to ground, 20-30 V |
| 20 | DI6 | Programmable digital input | 6.6 kΩ to ground, 20-30 V |
| 21 | DI7 | Programmable digital input | 6.6 kΩ to ground, 20-30 V |
| 22 | DO2 | Programmable digital output | PNP open collector, 24 V, 100mA max |
| 23 | DO3 | Programmable digital output | PNP open collector, 24 V, 100mA max |
| 24 | COM | Digital signal reference | Digital signal reference |

Notes:

1. AxN Series Drive has 4 single end analog inputs or 2 differential analog inputs, and they can be switched by software. The default mode is differential mode. When analog inputs are in differential mode, pin R0P (U1-1) and pin R0N (U1-2) map the R0 channel in software, and pin R1P (U2-14) and pin R1N (U2-15) map the R1 channel in software. On the other hand, when analog inputs

are in single end mode, pins: AI0 (U1-1), AI1 (U1-2), AI2 (U2-14) and AI3 (U2-15) respectively map channels AI0, AI1, AI2 and AI3 in software.

4.7 U3/U4 – Insulated User Connectors

Port Location

AxN Series Drive’s Insulated User Connectors (Male Plug, 2×12 pin) are on the right of the Communication Port Panel. Refer to the following figure for exact location.

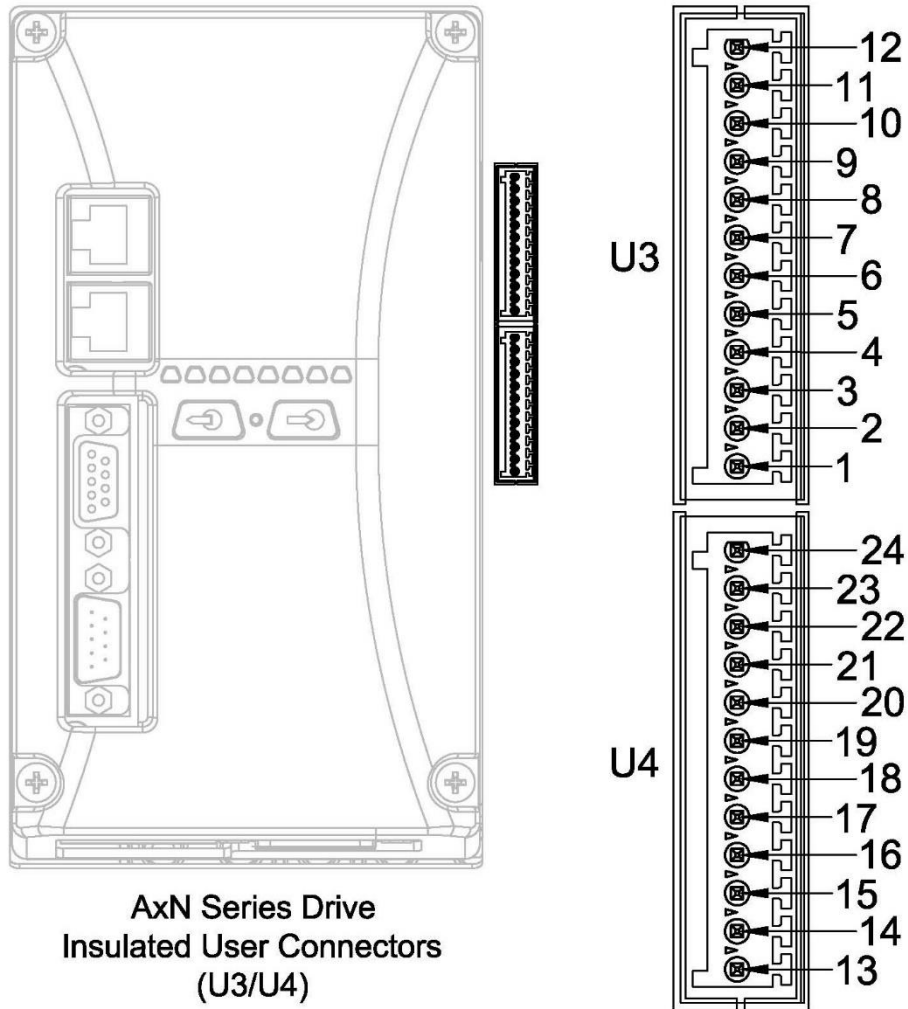

Diagram

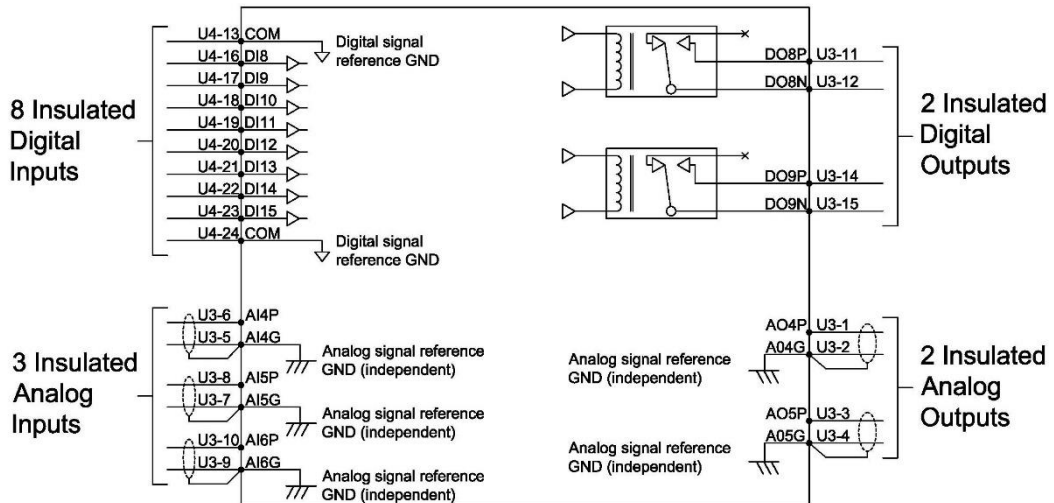

NOTE: All analog signal reference GND are independent, but all digital signal reference GND are the same.

Pin Assignment

Insulated User Connector U3

| Pin | Name | Function | Signal Description |
|-----|------|-----------------------------|------------------------------|
| 1 | AO4P | Programmable analog output | ±10V f.s., 30 mA |
| 2 | AO4G | Analog reference ground | Insulated reference ground |
| 3 | AO5P | Programmable analog output | ±10V f.s., 30 mA |
| 4 | AO5G | Analog reference ground | Insulated reference ground |
| 5 | AI4G | Analog reference ground | Insulated reference ground |
| 6 | AI4P | Programmable analog input | ±10V |
| 7 | AI5G | Analog reference ground | Insulated reference ground |
| 8 | AI5P | Programmable analog input | ±10V |
| 9 | AI6G | Analog reference ground | Insulated reference ground |
| 10 | AI6P | Programmable analog input | ±10V |
| 11 | DO8P | Programmable digital output | On/Off switch, 9V ~ 28Vdc/2A |
| 12 | DO8N | Programmable digital output | |

Insulated User Connector U4

| Pin | Name | Function | Signal Description |
|-----|------|-----------------------------|--|
| 13 | COM | Digital reference ground | Insulated reference ground for digital input |
| 14 | DO9P | Programmable digital output | On/Off switch, 9V ~ 28Vdc/2A |
| 15 | DO9N | Programmable digital output | |
| 16 | DI8 | Programmable digital input | 5mA, 24Vdc max |
| 17 | DI9 | Programmable digital input | 5mA, 24Vdc max |
| 18 | DI10 | Programmable digital input | 5mA, 24Vdc max |
| 19 | DI11 | Programmable digital input | 5mA, 24Vdc max |
| 20 | DI12 | Programmable digital input | 5mA, 24Vdc max |
| 21 | DI13 | Programmable digital input | 5mA, 24Vdc max |
| 22 | DI14 | Programmable digital input | 5mA, 24Vdc max |
| 23 | DI15 | Programmable digital input | 5mA, 24Vdc max |
| 24 | COM | Digital reference ground | Insulated reference ground for digital input |

5. APPENDIX: ACCESSORIES

5.1 Prefabricated Motor Power Output Cable

Order Code Definition

The Order Code can provide all the necessary specifications about a Prefabricated Motor Power Output Cable. Choose the specifications and use the corresponding order cable to order.

| Order Code | PW | -C | -D16 | -5 | -GTV |
|---------------------------|--|---|---------------|----|------|
| Cable Type | Power Cable | | | | |
| Terminal Type | Motor Side/Drive Side C = Ring terminal/Cord end terminal F = Ring terminal/Ring terminal S = Stripped wires/Cord end terminal R = Stripped wires/Ring terminal A = Aviation plug/Cord end terminal | | | | |
| Wire Gauge ⁽¹⁾ | D1.5=4×1.5mm ² D2.5=4×2.5mm ² D04 =4×4mm ² D06 =4×6mm ² D10 =4×10mm ² D16 =4×16mm ² D25 =4×25mm ² | B1.5=4×1.5mm ² +2×__mm ² B2.5=4×2.5mm ² +2×__mm ² B04 =4×4mm ² +2×__mm ² B06 =4×6mm ² +2×__mm ² B10 =4×10mm ² +2×__mm ² B16 =4×16mm ² +2×__mm ² B25 =4×25mm ² +2×__mm ² | | | |
| Length | 3=3m 5=5m 7=7m X ⁽²⁾ =X m | | | | |
| Shield Type | G = General shielded | I = General + Internal shielded | N = No shield | | |
| Trace Chain or Not | S = Standard | T = Trace chain | | | |
| Coat material | V = PVC | U = PUR ⁽³⁾ | | | |

Notes:

1. B in the Wire Gauge means power cable for motor with brake, the gauge of brake wires should be provided either;
2. Cable Length are not just 3, 5 and 7m, order whatever cable length you want;
3. Cable Coat made by PUR is oil resistant and wear resistant.

Example

Order Code: PW-C-D16-7-GTV

Power cable; terminal type of motor side is ring terminal, terminal type of drive side is cord end terminal; wire gauge is 4×16mm²; length is 7m; general shielded; trace chain; insulating layer material is PVC.

5.2 Prefabricated Encoder Cable (for Physis Motors)

Order Code Definition

The Order Code can provide all the necessary specifications about a Prefabricated Encoder Cable. Choose the specifications and use the corresponding order cable to order.

| Order Code | CE | -X | -A28 | -5 | -ISU | -XX |
|--------------------|--|----|------|----|------|-----|
| Cable Type | CN = Endat Encoder (EQN1325/ECN1313) CE = Endat Encoder (ECI1319/EQ1331) CS = Sincos Encoder CR = Resolver CH = Incremental with Hall sensor | | | | | |
| Terminal Type | X=Aviation plug / DB15(180°outlet) Y=Aviation plug/DB15(45°outlet) | | | | | |
| Wire Gauge | A28=AWG28 | | | | | |
| Length | 3=3m 5=5m 7=7m X ⁽¹⁾ =X m | | | | | |
| Shield Type | G = General shielded I = General + Internal shielded N = No shield | | | | | |
| Trace Chain or Not | S = Standard T = Trace chain | | | | | |
| Coat material | V = PVC U = PUR ⁽²⁾ | | | | | |
| Reserve Code | Reserve | | | | | |

Notes:

1. Cable Length are not just 3, 5 and 7m, order whatever cable length you want;
2. Cable Coat made by PUR is oil resistant and wear resistant.

Example

Order Code: CE-X-A28-5-ISU

Endat cable (ECI1319/EQ1331); terminal type of motor side is aviation plug, terminal type of drive side is DB15 connector(180 °outlet); internal diameter is AWG28; length 5m; general and internal shielded; standard, not trace chain; insulating layer material is PUR.

PHYSIS HEADQUARTER

Ningbo Physis Technology Co., Ltd.

No.308, Xiaogang Anju Road, Beilun District, Ningbo, China

Tel: +0086-(0)574-26922600

Marketing & Sales

Tel: +0086-(0)574-23459197

E-mail: Sales@physis.com.cn

After Sales

Tel: +0086-(0)574-23459183

E-mail: Aftersales@physis.com.cn