



液 压 伺 服 系 统 选 型 手 册

Hydraulic Servo System Selection Manual





Company Profile

企业简介

宁波菲仕技术股份有限公司（简称：菲仕技术）成立于 2001 年，由民营控股、先进制造产业投资基金和宁波和丰创业投资有限公司等战略投资人参股，公司致力于以电驱动技术为核心的创新及产业化，为运动控制和能量转换领域提供系统产品和综合解决方案，经过近 20 年的发展，菲仕已成为一家集研发、生产、销售为一体，拥有国内外多家控股子公司的集团化创新型高科技企业。

Ningbo Physis Technology Co., Ltd. (hereinafter referred to as Physis) was founded in 2001. Physis is a private holding group enterprise which is invested by Advanced Manufacturing Fund and Ningbo Hefeng Venture Capital Co., Ltd. Physis always devotes to innovation and industrialization of electrical drive technology, provides servo products and solutions for the field of motion control & energy conversion. With nearly 20 years' development, Physis becomes a collectivized & innovative high-tech enterprise, which collects together R&D, manufacturing and sales, and has a numbers of domestic and overseas subsidiaries.

R&D Team

研发团队

在智能制造全球化的趋势中，菲仕逐步落地国际化的战略布局，在欧洲成立了研发中心，与国内外专业科研机构、专家合作，进行定期交流和互动，以保持公司持续站在伺服系统科技创新的最前沿，共同推进产业发展。经过多年的沉淀，顶尖人才的积累，菲仕在国内还拥有省级企业技术中心和 200 余人具备独立研发能力的技术队伍，截止 2020 年底，拥有授权专利 303 项，其中发明专利 56 项，成为全国第一批高新技术企业！

In the globalization tendency of intelligent manufacture, Physis implements the strategic layout of the group internationalization gradually, establishes a R&D center in Europe to communicate and interact regularly with the world-class scientific research institution & industry experts at home and abroad, which helps Physis to hold on the lead of the servo system technology innovation and promotes industrial development together ! After years of development, accumulation of talents, Physis also has a provincial-level Enterprise Technology Center and a R&D team of more than 200 members in China who can conduct R&D activities independently. As one of the first batch of high-tech enterprise in China, Physis has 303 patents by the end of 2020, including 56 invention patents.

CONTENTS 目录

菲仕产品 Physis Products	01
伺服系统解决方案 Servo System Solution	02
Express 系列伺服电机代码 Servo Motor Code	03
E010__F 伺服电机规格 Technical Data	04
E010__F 电机性能曲线 Performance Curve	06
E012__F 伺服电机规格 Technical Data	08
E012__F 电机性能曲线 Performance Curve	10
PH300 系列驱动器代码 Servo Drive Code	12
PH300 系列驱动器主要特性 Technical Specifications	13
PH300 系列驱动器规格 Technical Data	14
PH300 系列驱动器外形尺寸 Dimensions	15
液压伺服系统选型 Hydraulic Servo System Selection	16
注塑机专用接线图 Connection Diagram	17
联系我们 Contact Information	17

Express 系列交流永磁同步伺服电机

菲仕研发的新一代高性能伺服电机，该系列电机拥有更高的功率密度，更好的伺服响应速度和过载输出特性，强制风冷，除一般的液压伺服领域外，特别适合需要高速响应和短时过载要求高的应用场合，如高速节能注塑机、压铸机等。

额定功率范围：7.9kW~75kW

额定扭矩范围：50Nm~360Nm

峰值扭矩范围：150Nm~920Nm

适配主流油泵：16cc~160cc

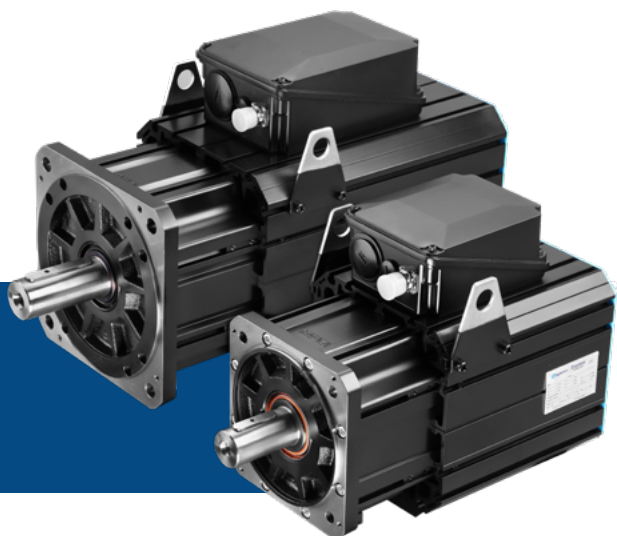

Express Series Servo Motor

Express series servo motor is a new generation of high performance servo motor that has higher power density, higher response speed and good overload output characteristic, fan cooling. Specially suitable for some applications which need high requirements of high speed response and short-time overload, such as high speed energy-saving injection molding machine, die-casting machine, etc.

Rated power range : 7.9kW~75kW

Rated torque range : 50Nm~360Nm

Peak torque range : 150Nm~920Nm

Pump option : 16cc~160cc

PH300 系列高性能闭环矢量驱动器

功率范围：7.5kW~450kW

支持闭环矢量控制，内置 PID 控制

支持 Modbus 通讯协议，支持多种类型 PG 卡

具备快速限流功能，减少驱动器频繁出现故障报警的概率

性能优越，环境适应性好，结构简单，体积小，便于安装

过载能力强，150% 额定电流可持续 60S，180% 额定电流可持续 3S

保护功能完备，具有输出缺相保护、过流 / 过压过载 / 过热保护等功能

PH300 Series Servo Drive

Power range : 7.5kW~450kW

Close-loop vector control, built-in PID control

Modbus communications protocol, multi-type PG card

Fast current limiting function, reduce failure alarms

Superior performance, good environmental adaptability, simple structure, small size, easy installation

Strong overload ability, 60s for 150% rated current, 3s for 180% rated current

Complete protection functions, output phase loss protection, overcurrent/overload/overheat protection, etc



Servo System Solution

伺服系统解决方案

配置

控制系统、交流伺服驱动器、交流永磁伺服电机、油泵、速度反馈单元、压力反馈单元等

Configurations

Control system, servo drive, PM servo motor, oil pump, speed feedback unit, pressure feedback unit, etc

优势

PQ 控制
压力控制稳定；压力波动低于 0.5bar
性能稳定，可靠；重复定位精度高，噪音低
节能高效，节能率 30%~70%
快速响应，响应时间低于 30ms

Advantages

PQ control
Pressure control stability, pressure fluctuations < 0.5Bar
Performance stability & reliability
High position repeat accuracy, low noise
Energy efficiency 30%~70%
Quick response < 30ms

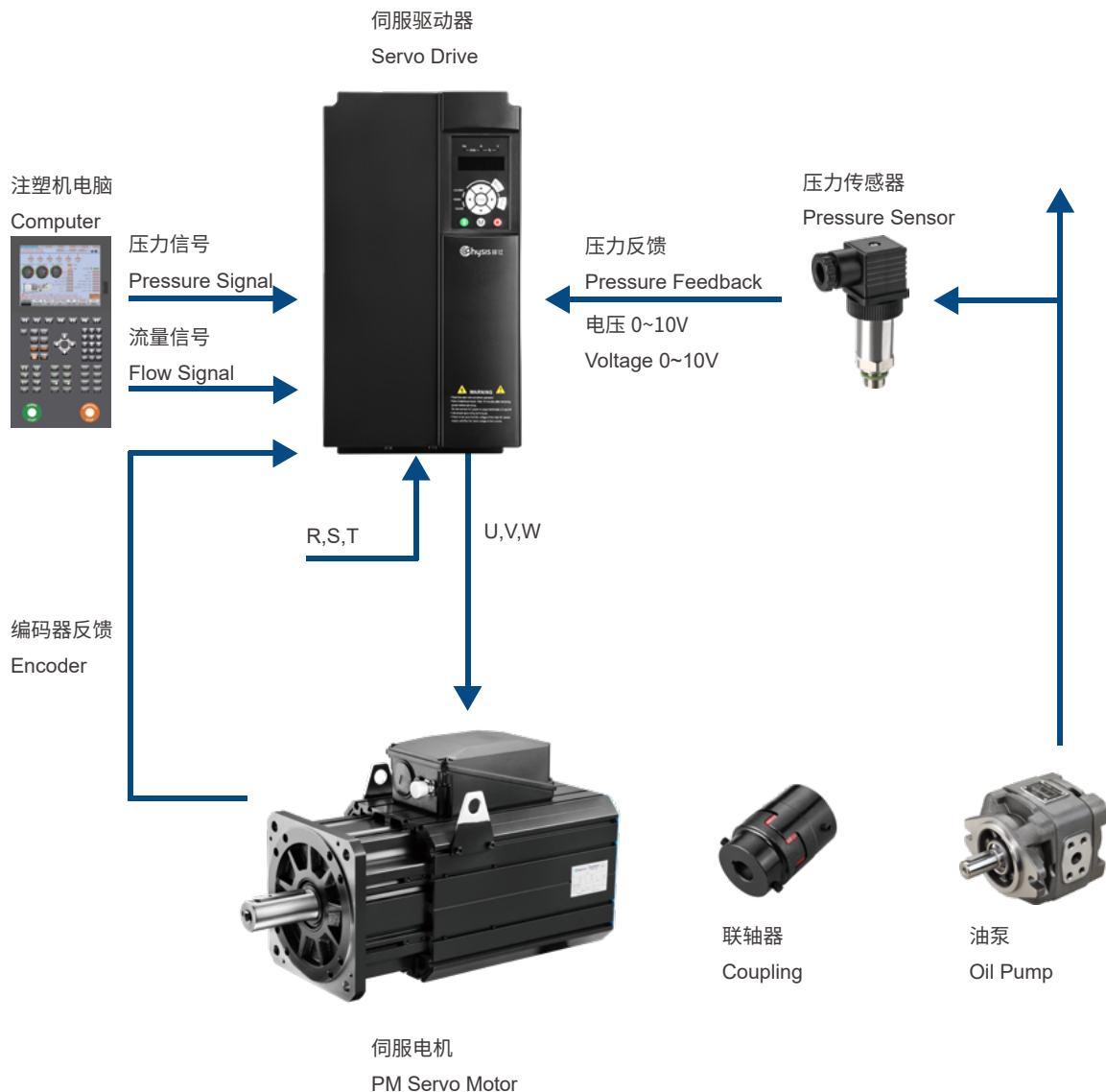

E 0 1 0 0 7 F 2 0 3 R 4 0 Y 0 K b 1 - T F

电机类型 Series Identify	框号 Size	冷却方式 Cooling	额定转速 Rated Speed	额定电压 Rated Voltage	编码器 Sensor Identify	制动器 Brake	接线方式 Connection	转轴 Shaft	底板 Mounting Feet	接线盒位置 Position of Terminal Box	出线孔方向 Direction of Cable Hole
-------------------------	------------	-----------------	---------------------	-----------------------	------------------------	--------------	--------------------	-------------	---------------------	-----------------------------------	----------------------------------

1004, 1005, 1007, 1008,
1010, 1012 1013,1215,
1220, 1225, 1230, 1235

F = 强制风冷
Fan cooling

数字 *100 = 1500 rpm, 2000 rpm

3 = 380 Vac

R4 = 旋转变压器, 1 对极, BRX
Resolver, 1X - BRX

0 = 无制动器
Without brake

K = 带键槽, 标准键
Shaft with key

00 = 无底板
Without feet
b1 = 标准底板
Standard feet

轴伸方向看
Look from the direction
of shaft
T= 接线盒在上
Terminal box on top
L= 接线盒在左
Terminal box on the
left
R= 接线盒在右
Terminal box on the
right

F= 出线孔朝前
Cable hole
in front
B= 出线孔朝后
Cable hole
in the back

Y0 = 电源接线端子, 信号航空插座
Signal circular connector

代码示例 :

E01007F203R40Y0Kb1-TF

Express 0 系列, 框号 1007, 强制风冷, 额定转速 2000rpm, 电压等级 380Vac, 旋转变压器, 1 对极, BRX, 无制动器, 电源接线端子, 信号航空插座, 伸出轴带键, 标准底板, 轴伸方向看, 接线盒朝上, 出线孔朝前。

Code Example:

E01007F203R40Y0Kb1-TF

Express 0 series motor, size 1007, servo fan cooling, 2000rpm, 380Vac, resolver, 1X - BRX, without brake, signal circular connector, shaft with key, standard feet, look from the direction of motor shaft, terminal box on top, cable hole in front.

Express 系列伺服电机规格 (E010__F)

电机型号 Motor Code		E01004F		E01005F		E01007F		E01008F		E01010F		E01012F		E01013F	
额定转速 Rated Speed	wn [rpm]	1500	2000	1500	2000	1500	2000	1500	2000	1500	2000	1500	2000	1500	2000
额定频率 Rated Freq	Fn [Hz]	100	133	100	133	100	133	100	133	100	133	100	133	100	133
最大速度 Max Speed	wmax [rpm]	3500													
最大频率 Max Freq	Fmax [Hz]	233													
堵转电流 Stall Current	Io [A]	15	20	24	31	31	42	42	52	48	62	56	77	61	77
额定电流 Rated Current	In [A]	15	19	23	29	29	38	39	47	45	56	52	69	57	69
堵转扭矩 Stall Torque	To [Nm]	53		78		106		132		158		183		208	
额定扭矩 Rated Torque	Tn [Nm]	50	50	75	73	100	97	124	121	148	143	171	165	193	187
额定功率 Rated Power	Pn [kW]	7.9	10	12	15	16	20	20	25	23	30	27	34	30	39
扭矩常数 Torque Constant	Kt [Nm/A]	3.43	2.57	3.38	2.60	3.46	2.60	3.25	2.60	3.38	2.60	3.33	2.42	3.46	2.77
反电动势 Back EMF	EMF [V/krpm]	208	156	204	157	210	157	197	157	204	157	202	147	210	168
绕组线电阻 Winding Resistance	Rw [ohm]	1.67	0.892	0.825	0.465	0.543	0.322	0.37	0.233	0.319	0.179	0.244	0.133	0.222	0.145
直轴线电感 Direct Inductance	Ld [mH]	18.2	10.2	11.5	6.8	9.1	5.1	6.4	4.1	5.8	3.4	4.8	2.5	4.5	2.9
交轴线电感 Quadrature Inductance	Lq [mH]	42.7	24.0	27.1	16.0	21.4	12.0	15.0	9.6	13.5	8.0	11.3	6.0	10.7	6.8
最大电流 Max Current	Imax [A]	50	66	80	100	100	135	135	170	155	200	183	250	200	250
最大扭矩 Max Torque	Tmax [Nm]	145		222		297		371		445		520		594	
转动惯量 Rotor inertia	Jm[kgcm ²]	56		80		103		126		150		173		196	
电机重量 Weight	M[kg]	40		47		54		61		68		75		82	

驱动器电压 Vdrive[Vac] : 380Vac

直流母线电压 Vdcbus[Vdc] : 537Vdc

载波频率 PWM frequency[kHz] : 4kHz

温升 DT[K] : 100K

环境温度 Tamb[°C] : 30°C

	B	L
E01004F	267	342
E01005F	285	378
E01007F	312	414
E01008F	354	450
E01010F	396	486
E01012F	400	527
E01013F	471	558

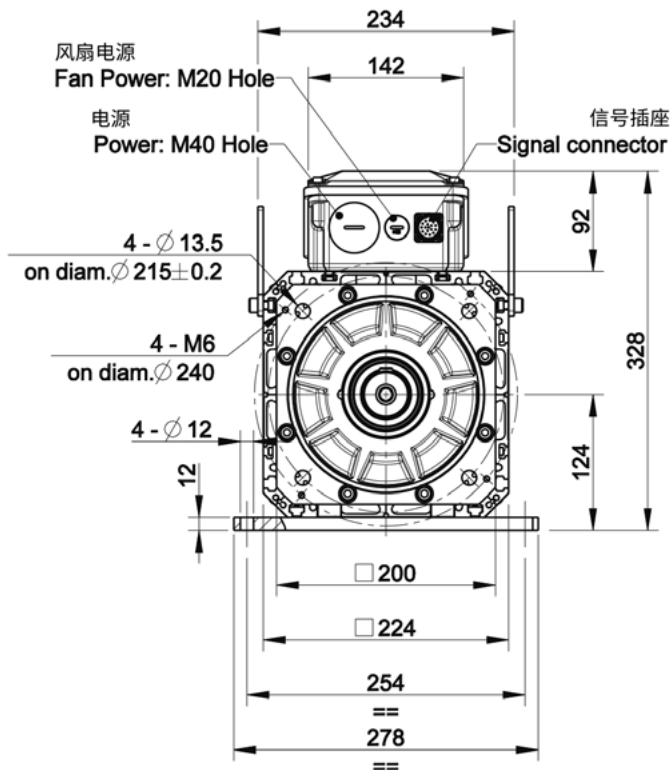
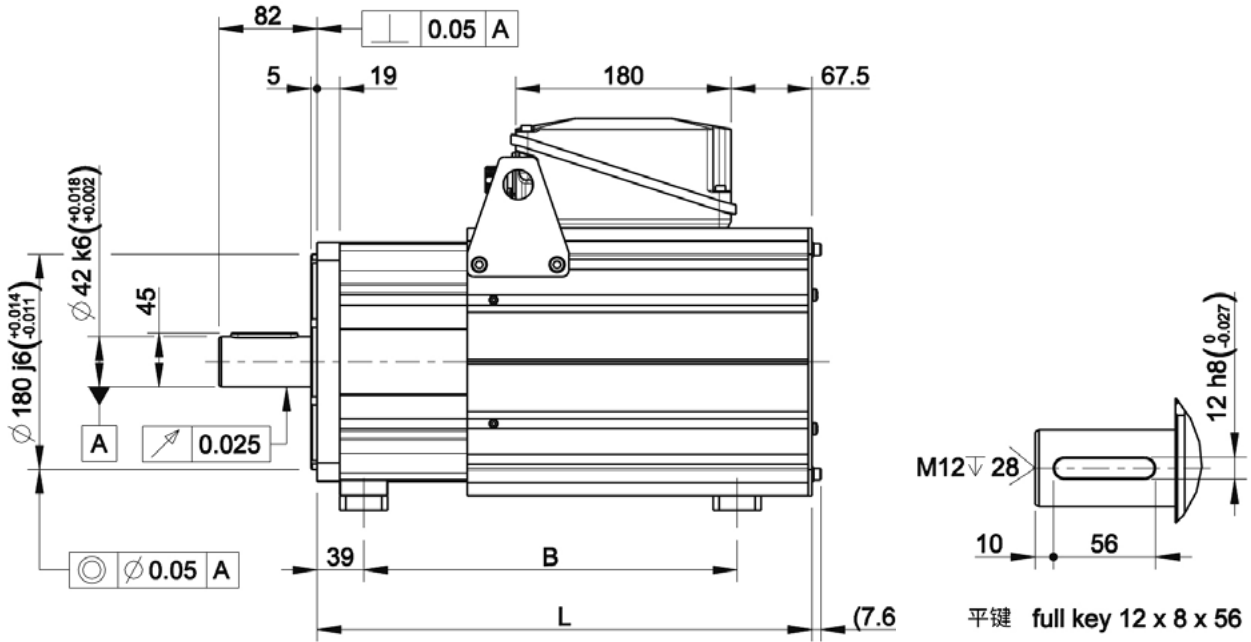
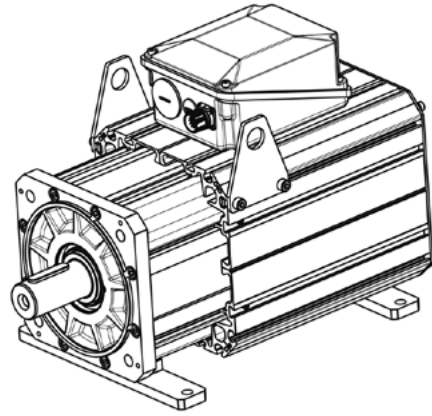

针脚号 PIN	线色 WIRE COLOR	定义 FUNCTION
1	n.c.	n.c.
2	n.c.	n.c.
3	n.c.	n.c.
4	YELLOW 黄	SIN-
5	RED 红	COS+
6	BLACK 黑	COS-
7	RED / WHITE 红 / 白	RESX+
8	BROWN 棕	KTY+
9	WHITE 白	KTY-
10	YELLOW / WHITE 黄 / 白	RESX-
11	n.c.	n.c.
12	n.c.	n.c.
13	n.c.	n.c.
14	BLUE 蓝	SIN+
15	n.c.	n.c.
16	BLUE 蓝	PTC+
17	BLUE 蓝	PTC-

信号插座
Signal Connector
M23 Size 1-17 Pin

旋转变压器 Resolver : 1X-BRX

Performance Curve

电机性能曲线 (E010__F)

驱动器电压 $V_{drive}[Vac]$: 380Vac

直流母线电压 $V_{dcbus}[Vdc]$: 537Vdc

载波频率 PWM frequency[kHz] : 4kHz

温升 $DT[K]$: 100K

环境温度 $T_{amb}[^{\circ}C]$: 30 $^{\circ}C$

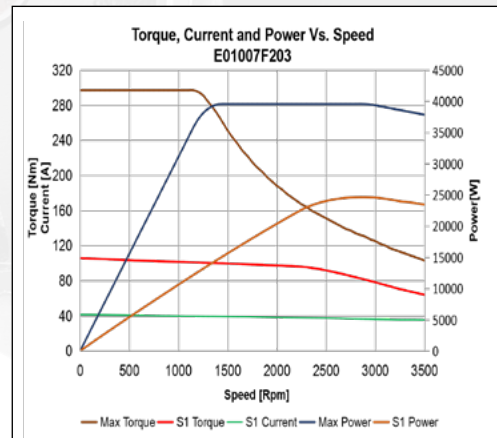
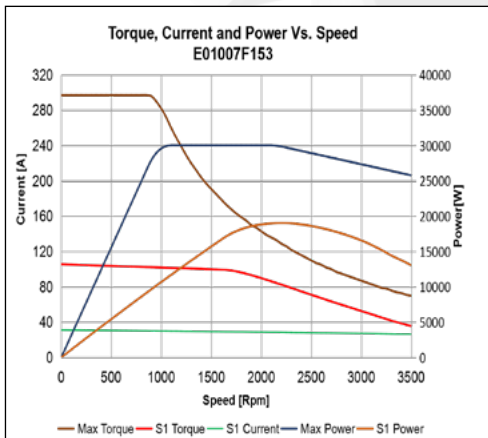
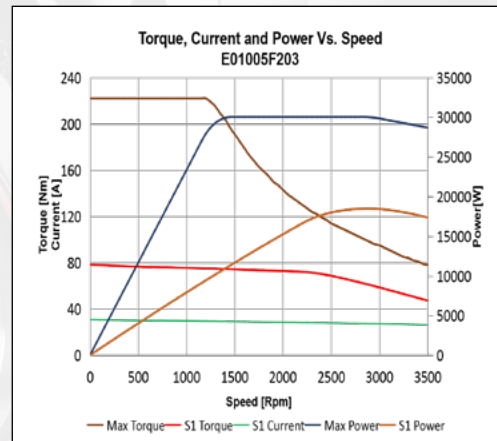
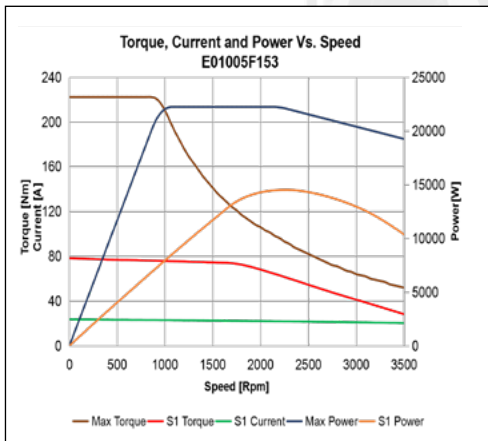
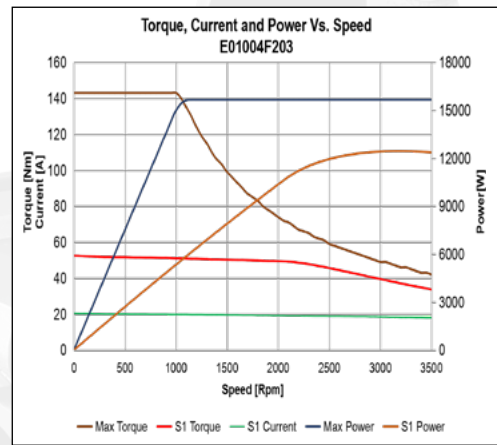
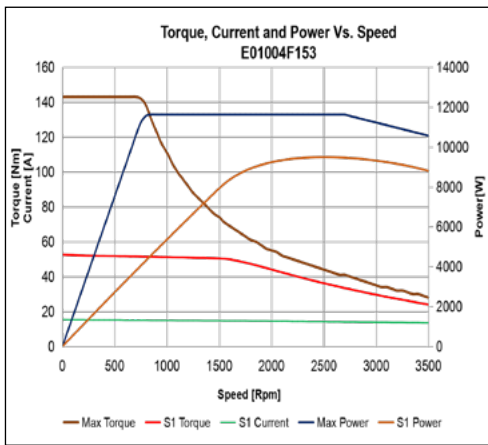
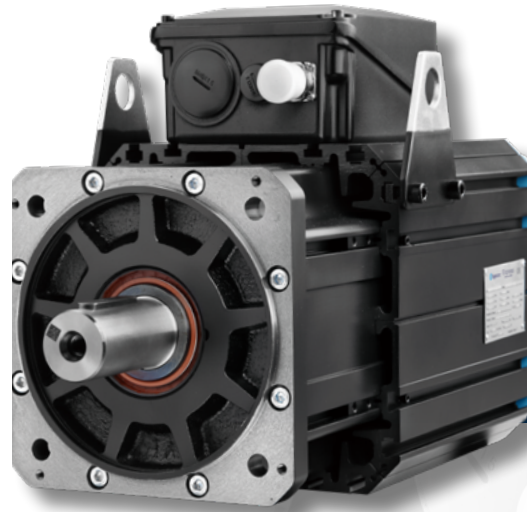

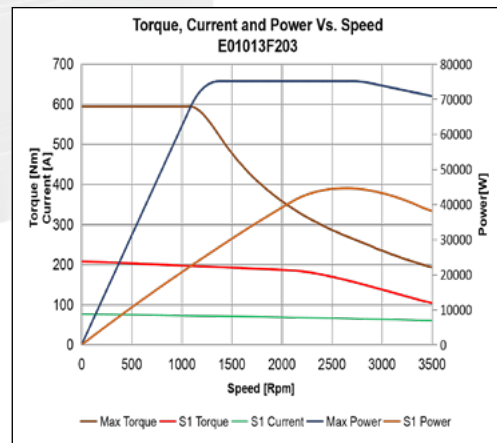
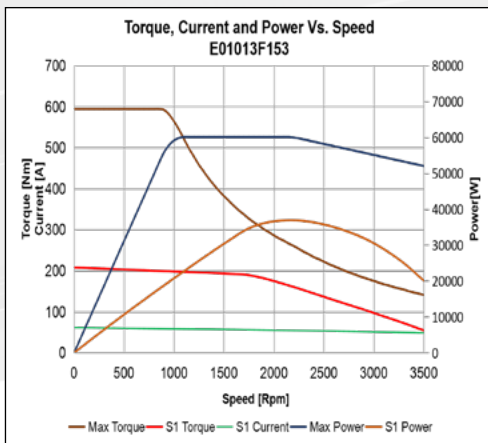
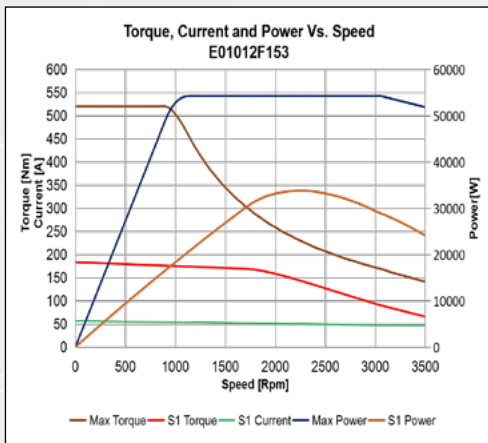
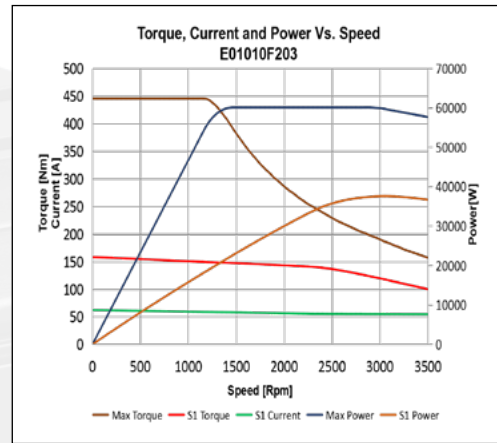
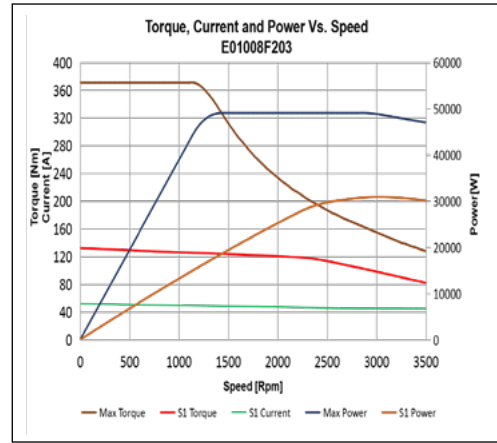
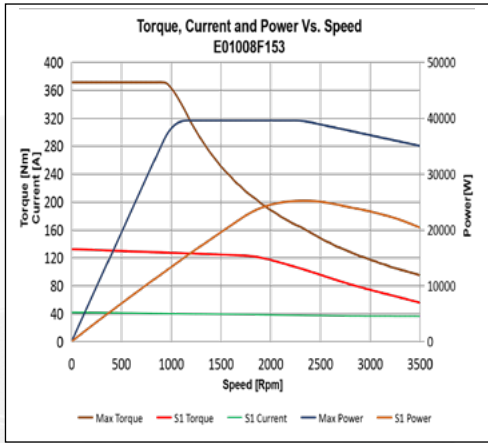

Express 系列伺服电机规格 (E012__F)

电机型号 Motor Code		E01215F		E01220F		E01225F		E01230F		E01235F	
额定转速 Rated Speed	wn [rpm]	1500	2000	1500	2000	1500	2000	1500	2000	1500	2000
额定频率 Rated Freq	Fn [Hz]	100	133	100	133	100	133	100	133	100	133
最大速度 Max Speed	wmax [rpm]	3500									
最大频率 Max Freq	Fmax [Hz]	233									
堵转电流 Stall Current	Io [A]	70	85	85	109	95	127	108	151	125	187
额定电流 Rated Current	In [A]	64	75	78	95	86	109	100	134	115	164
堵转扭矩 Stall Torque	To [Nm]	224		279		332		378		428	
额定扭矩 Rated Torque	Tn [Nm]	206	197	255	243	300	285	351	336	395	377
额定功率 Rated Power	Pn [kW]	32	41	40	51	47	60	55	70	62	79
扭矩常数 Torque Constant	Kt [Nm/A]	3.27	2.67	3.34	2.60	3.57	2.67	3.64	2.60	3.57	2.38
反电动势 Back EMF	EMF [V/krpm]	198	162	203	158	216	162	221	158	216	144
绕组线电阻 Winding Resistance	Rw [ohm]	0.157	0.106	0.123	0.074	0.110	0.062	0.095	0.049	0.078	0.034
直轴线电感 Direct Inductance	Ld [mH]	4.1	2.7	3.4	2.1	3.2	1.8	2.9	1.5	2.4	1.1
交轴线电感 Quadrature Inductance	Lq [mH]	9.6	6.4	8.0	4.9	7.6	4.3	6.8	3.5	5.7	2.5
最大电流 Max Current	Imax [A]	155	190	190	245	210	280	240	335	280	420
最大扭矩 Max Torque	Tmax [Nm]	467		585		700		800		920	
转动惯量 Rotor Inertia	Jm[kgcm ²]	253		310		370		427		485	
电机重量 Weight	M[kg]	102		116		130		144		158	

驱动器电压 Vdrive[Vac] : 380Vac

直流母线电压 Vdcbus[Vdc] : 537Vdc

载波频率 PWM frequency[kHz] : 4kHz

温升 DT[K] : 100K

环境温度 Tamb[°C] : 30°C

	B	L
E01215F	400	539
E01220F	450	589
E01225F	500	639
E01230F	550	689
E01235F	600	739

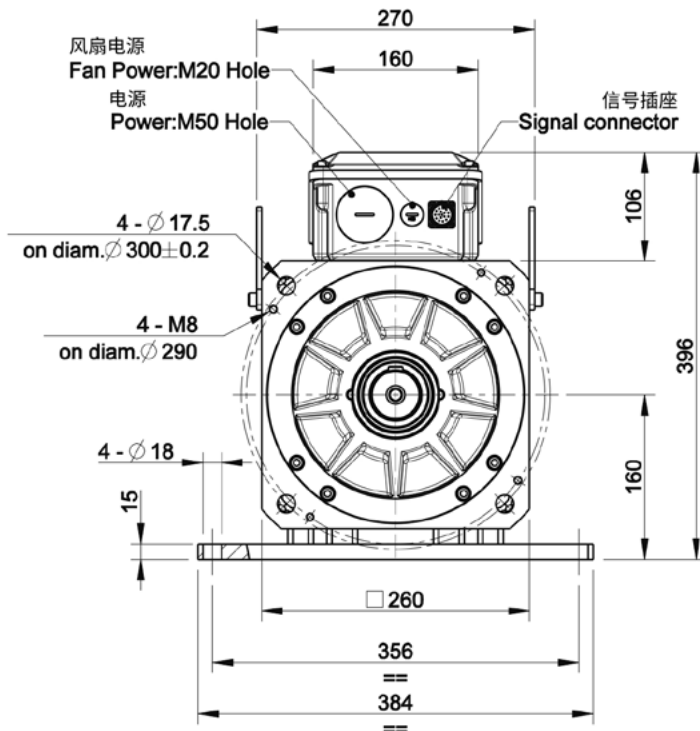
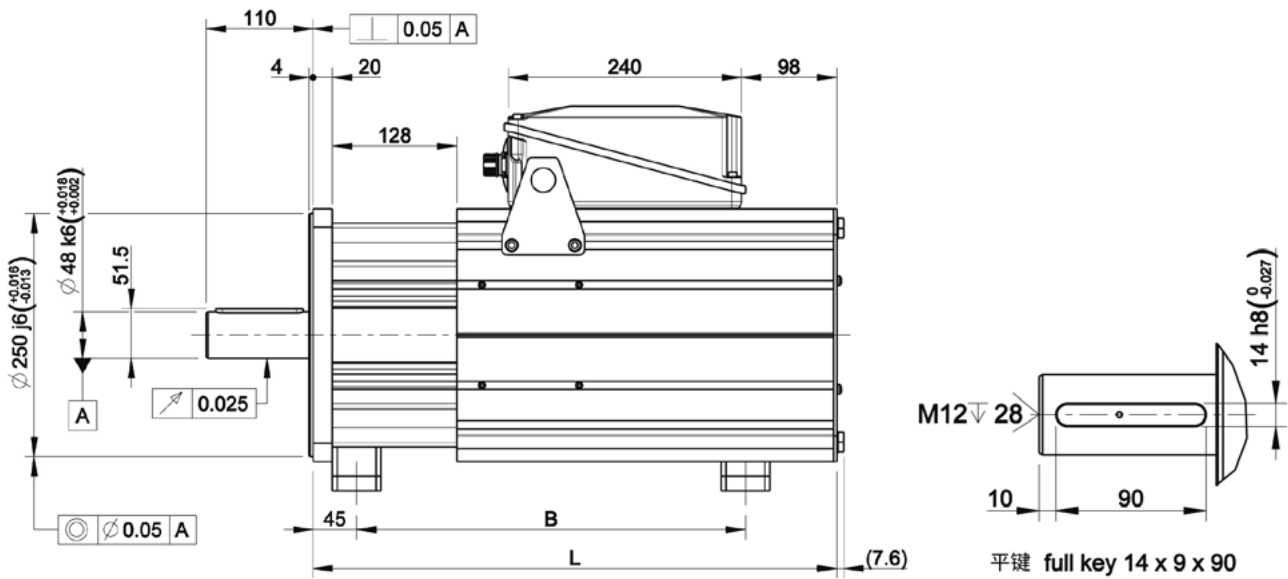
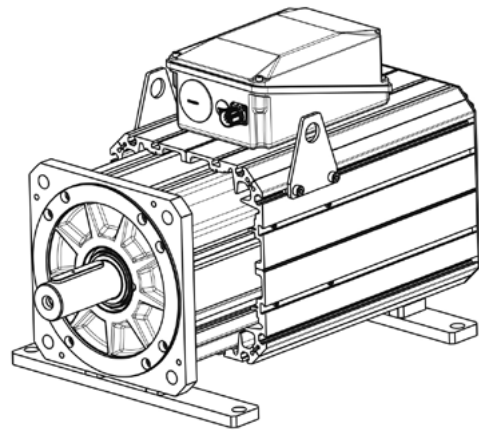

针脚号 PIN	线色 WIRE COLOR	定义 FUNCTION
1	n.c.	n.c.
2	n.c.	n.c.
3	n.c.	n.c.
4	YELLOW 黄	SIN-
5	RED 红	COS+
6	BLACK 黑	COS-
7	RED / WHITE 红 / 白	RESX+
8	BROWN 棕	KTY+
9	WHITE 白	KTY-
10	YELLOW / WHITE 黄 / 白	RESX-
11	n.c.	n.c.
12	n.c.	n.c.
13	n.c.	n.c.
14	BLUE 蓝	SIN+
15	n.c.	n.c.
16	BLUE 蓝	PTC+
17	BLUE 蓝	PTC-

信号插座
Signal Connector
M23 Size 1-17 Pin

旋转变压器 Resolver : 1X-BRX

Performance Curve

电机性能曲线 (E012__F)

驱动器电压 $V_{drive}[Vac]$: 380Vac
 直流母线电压 $V_{dcbus}[Vdc]$: 537Vdc
 载波频率 PWM frequency[kHz] : 4kHz
 温升 $DT[K]$: 100K
 环境温度 $T_{amb}[^{\circ}C]$: 30 $^{\circ}C$

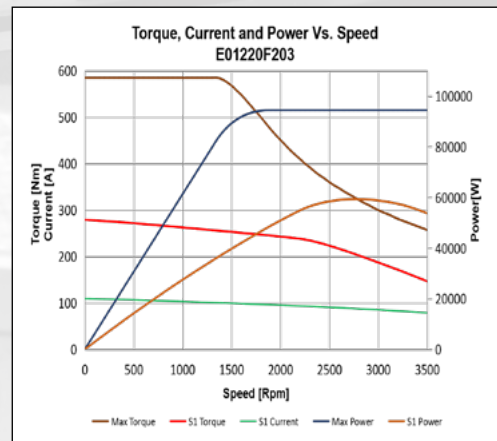
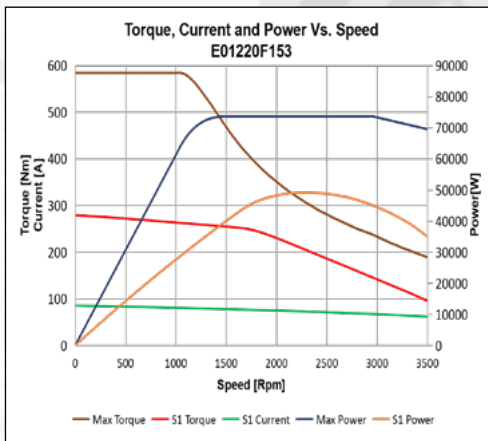
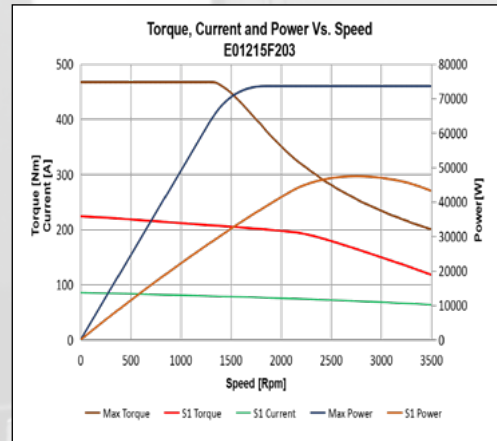
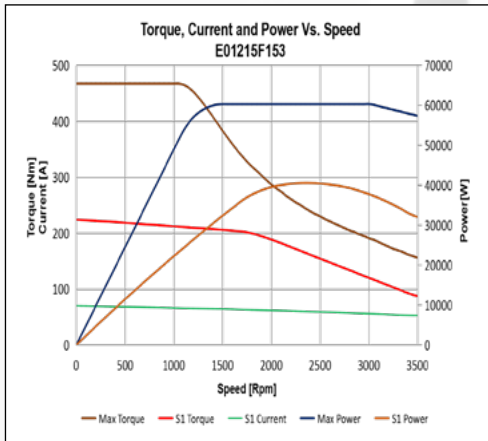
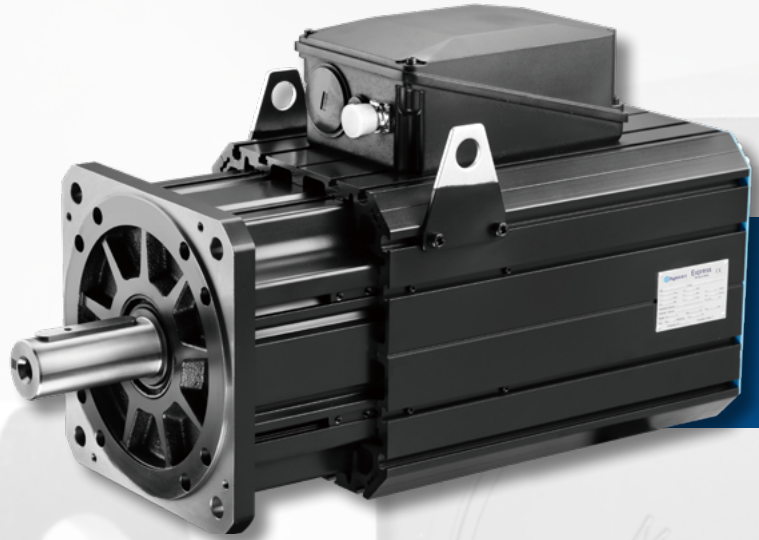

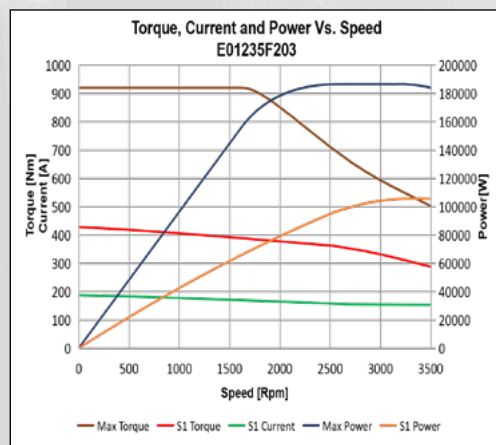
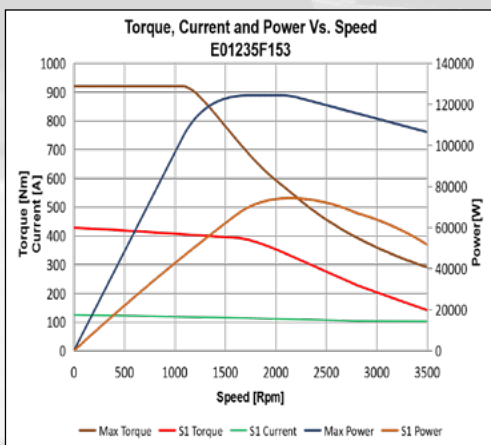
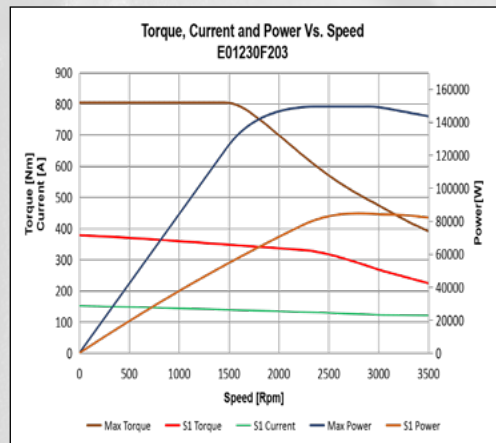
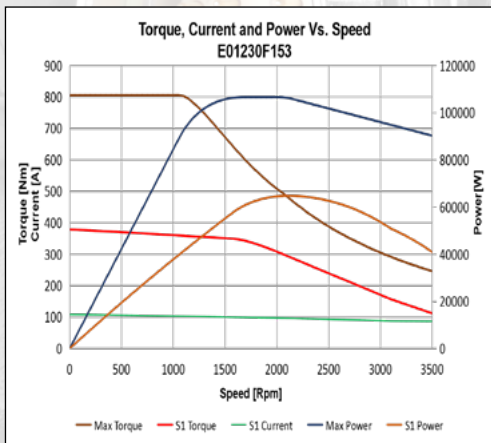
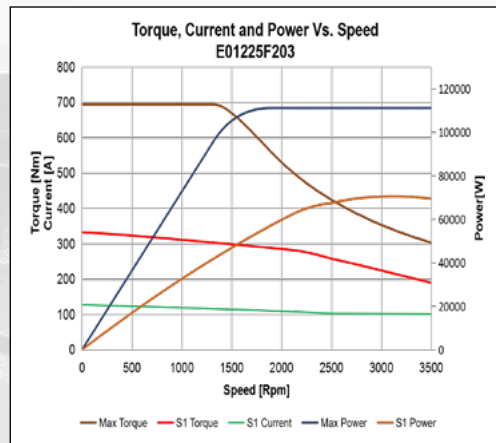
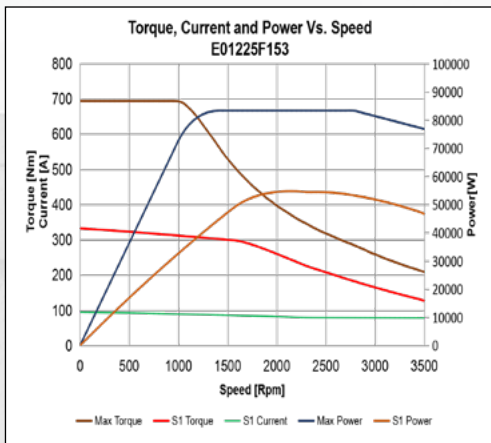

PH300-011-43 ARMF-XX

驱动器系列识别 驱动器功率识别 电压等级 硬件版本 PG 卡 总线识别 冷却方式识别 客户定制机识别码
 Series Identify Power Identify Voltage Class Hardware Version PG Card Communication Bus Cooling Customized Drive Identification



代码示例：

PH300.011.43ARMF

菲仕 PH300 系列伺服驱动器，功率 11kW，380V 输入三相电压，A 版硬件版本，旋转变压器，总线 Modbus，强制风冷

Code Example:

PH300.011.43ARMF

PH 300 servo series drive, 11kW, input voltage 380V, hardware version A, resolver encoder, modbus communication bus, fan cooling

Technical Specifications

PH300 系列伺服驱动器主要特性

项目 Item	描述 Descripion
最高频率 Max Frequency	0 ~ 599Hz
载波频率 PWM Frequency	根据负载特性自动调整载波频率 1KHz ~12KHz According to load characteristics, PWM frequency auto-adjustment 1KHz~12kHz
输入频率分辨率 Input Frequency Resolution	数字设定 Digital Setting : 0.01Hz 模拟设定 : 最高 $\times 0.025\%$ Analog setting : Max frequency $\times 0.025\%$
控制方式 Control Mode	闭环矢量控制 (FVC) Close-Loop Vector Control
启动转矩 Startup Torque	0Hz/180%
调速范围 Speed Tange	1 : 1000(FVC)
稳速精度 Speed Stability Accuracy	$\pm 0.02\%$ (FVC)
转矩控制精度 Torque Control Accuracy	$\pm 5\%$ (FVC)
过载能力 Overload Capacity	150% 额定电流 60s; 180% 额定电流 3s 60s for 150% of the rated current, 3s for 180% of the rated current
加减速曲线 Ramp Curve	直线或 S 曲线加减速, 4 种加减速时间, 加减速时间范围 : 0.0~6500.0s Straight-line or S-curve, 4 kinds of acceleration and deceleration time, acceleration & deceleration time range : 0.0s~6500.0 s
通讯协议 Communication	Modbus/CAN Open
运行指令 Operation Instruction	操作面板给定、控制端子给定、串口通讯口给定, 可通过多种方式切换 Operation panel, control terminals or series port communication
频率指令 Frequency Order	多种频率指令: 数字给定、模拟电压给定、模拟电流给定、脉冲给定、串行口给定, 可通过多种方式切换 Multiple frequency orders: digital, analog voltage, analog current, pulse or series port communication
快速限流功能 Fast Current Limiting Function	最大限度减小过流故障, 保护驱动器正常运行 Minimizing overcurrent fault, protect drives' good running
多种编码器支持 PG Card Option	支持差分、开路集电极、旋转变压器等编码器 Differential input PG card, open collector input PG card, resolver PG card,etc
过压过流失速控制 Overvoltage/ Overcurrent Stall Torque	对运行期间电流电压自动限制, 防止频繁过流过压跳闸 The current and voltage are limited automatically during the running process, avoiding frequent tripping due to overvoltage/overcurrent

项目 Item	描述 Descripion	
输入端子 Input Terminals	3 个模拟量输入端子, 2 个仅支持 $\pm 10V$ 电压输入, 1 个支持 $\pm 10V$ 电压输入或 0~20mA 电流输入 3 analog input terminals, 2 of them only support $\pm 10V$ voltage signals, 1 support $\pm 10V$ voltage signals input or 0~20mA current signals input	
	1 个电机过热保护输入端子, 支持 PTC130、PTC150 One motor overheat protection input terminals, support PTC130, PTC150	
输出端子 Output Terminals	标准: 3 个继电器输出端子, 1 个常闭端子, 2 个常开端子 Standard : 3 relay output terminals, 1 is NC terminal, 2 is NO terminal	
	2 个模拟输出端子, 支持 0~20mA 电流输出或 0~10V 电压输出 2 analog output terminals, 0~20mA current output or 0~10V voltage output	
保护功能 Protection	缺相保护 Phase Loss Protection	输出缺相保护 Output phase loss protection
	瞬间 过电流保护 Instantaneous Overcurrent Protection	在额定输出电流的 250% 以上时停机 Stop drive for over 250% of the rated current
	过压保护 Overvoltage Protection	主回路直流电压在 820V 以上时停机 Stop drive for main circuit DC voltage more than 820V
	欠压保护 Under Voltage Protection	主回路直流电压在 350V 以下时停机 Stop drive for main circuit DC voltage lower than 350V
	过热保护 Overheat Protection	逆变桥过热时会触发保护 Inverter bridge overheat will start overheat protection
	过载保护 Overload Protection	150% 额定电流运行 60S 停机, 180% 额定电流运行 3S 停机 60s for 150% of rated current or 3s for 180% of rated current will stop the drive
	过流保护 Overcurrent Protection	超过伺服驱动器 2.5 倍额定电流停机保护 Stop drive for over 250% of the rated current
	短路保护 Short-circuit Protection	输出相间短路保护, 输出对地短路保护 Output phase-phase short circuit detection; Output Phase-GND short-circuit protection

PH300 系列伺服驱动器规格

PH300__43_RMF	007	011	015	018	022	030	037	045	055	075	090	110	132	160	185	200	220	250	280	315	355	400	450		
额定输出功率 (kW) Rated Output Power	7.5	11	15	18.5	22	30	37	45	55	75	90	110	132	160	185	200	220	250	280	315	355	400	450		
额定输出电流 (A) Rated Output Current	17	25	32	37	45	60	75	90	110	150	176	210	253	300	340	380	420	470	520	600	640	690	790		
A 版本 Version A	额定输入电流 (A) Rated Input Current	20	30	37	42	51	67	82	99	115	157	183	214	256	307	350	385	430	468	525	610	665	700	800	
	净重 (Kg) Net Weight	4.5	4.5	5	5	5.2	9.9	10	20.5	21	29	29.5	30	55	56.5	/	/	/	/	/	/	/	/	/	
	框号 Size	B			C			D			E			F			/	/	/	/	/	/	/	/	/
	尺寸: 宽 * 高 * 深 (mm) Dimension W*L*H	151*332*183			217*400*216			300*440*240			275*590*310			400*675*310			/	/	/	/	/	/	/	/	/
B 版本 Version B	额定输入电流 (A) Rated Input Current	/	/	/	/	/	/	89	106	139	164	196	240	287	330	368	405	455	505	580	620	670	765		
	净重 (Kg) Net Weight	/			/			29.5	30	33.5	48.5	49	96.5	97	118	118.5	118.5	148	125	127.5	173.5	175.5	178.5		
	框号 Size	/			/			C1		D1		E1		F1		G1		H1		I1		J1			
	尺寸: 宽 * 高 * 深 (mm) Dimension W*L*H	/			/			300*500*253		*1		338*550*300		400*872*310		300*1445*500		*2		325*1495*545		335*1720*545			
制动单元 Brake Unit	内置制动单元 Internal brake unit														无内置制动单元, 需外购制动单元 Without internal brake unit, needs to be purchased separately										
直流电抗器 DC Reactor	无内置直流电抗器 Without internal DC reactor							A 版无内置 / B 版有内置直流电抗器 Version A without internal DC reactor Version B within internal DC reactor							内置直流电抗器 Internal DC reactor										
输入电源 Power Supply	三相电源 380Vac~480Vac±10% 50Hz/60Hz																								
输出频率范围 Output Frequency	0~599Hz																								

*1 = 338*546*257 (75kW / B 版)

*2 = 330*1595*545 (250kW / B 版)

PH300__23ARMF	007	011	015	018	022	030	37	045	055	075	090	
额定输出功率 (kW) Rated Output Power	7.5	11	15	18.5	22	30	37	45	55	75	90	
额定输入电流 (A) Rated Input Current	37	51	67	82	99	115	157	183	214	307	350	
额定输出电流 (A) Rated Output Current	32	45	60	75	90	110	152	176	210	304	340	
净重 (Kg) Net Weight	4.5	4.7	5	5	20	20.5	28	28.5	29	55	91	
框号 Size	B		C			D		E			F	G
尺寸: 宽 * 高 * 深 (mm) Dimension W*L*H	151*332*183		217*400*216			300*440*240		275*590*310			400*675*310	300*1445*500
制动单元 Brake Unit	内置制动单元 Internal brake unit											
直流电抗器 DC Reactor	无内置直流电抗器 Without internal DC reactor											
输入电源 Power Supply	三相电源 200Vac~240Vac±10% 50Hz/60Hz											
输出频率范围 Output Frequency	0~599Hz											

Dimensions

PH300 系列伺服驱动器外形尺寸

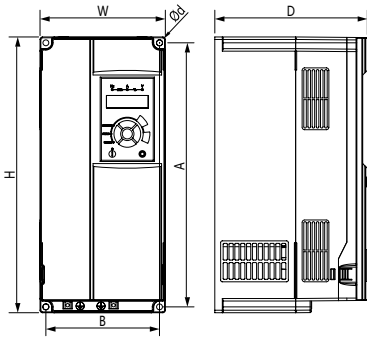

图一 Figure 1

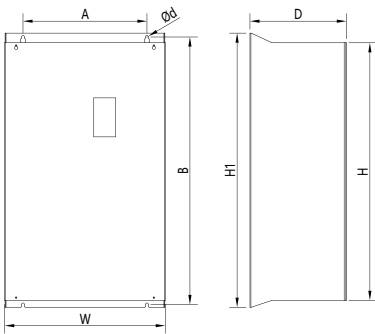

图二 Figure 2

版本 Version	框号 Size	驱动器型号 Drive Code		W	H	D	A	B	Ød	H1	备注 Remarks
A 版本 Version A	B	PH300.007.43ARMF	PH300.011.43ARMF	151	332	183	318	137	7	----	参考图一 Figure 1
		PH300.015.43ARMF	PH300.018.43ARMF								
		PH300.022.43ARMF	PH300.007.23ARMF								
		PH300.011.23ARMF									
	C	PH300.030.43ARMF	PH300.037.43ARMF	217	400	216	385	202	7	----	
		PH300.015.23ARMF	PH300.018.23ARMF								
	D	PH300.045.43ARMF	PH300.055.43ARMF	300	440	240	200	455	9	470	
		PH300.022.23ARMF	PH300.030.23ARMF								
	E	PH300.075.43ARMF	PH300.090.43ARMF	275	590	310	200	612	9	630	
		PH300.110.43ARMF	PH300.037.23ARMF								
PH300.045.23ARMF		PH300.055.23ARMF									
F	PH300.132.43ARMF	PH300.160.43ARMF	400	675	310	320	695	11	715		
	PH300.075.23ARMF										
B 版本 Version B	C1	PH300.045.43BRMF	PH300.055.43BRMF	300	500	253	200	522	9	540	参考图二 Figure 2
	D1	PH300.075.43BRMF		338	546	257	270	560	9	576	
	E1	PH300.090.43BRMF	PH300.110.43BRMF	338	550	300	270	564	9	580	
	F1	PH300.132.43BRMF	PH300.160.43BRMF	400	872	310	320	895	11	915	

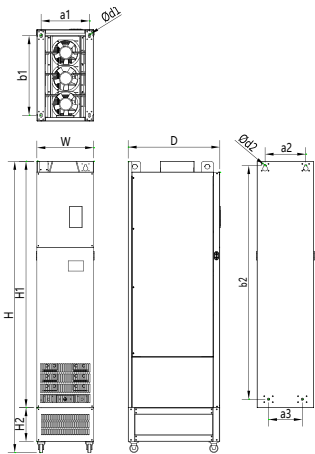

图三 Figure 3

版本 Edition	框号 Size	驱动器型号 Drive Code	外形尺寸 Dimension					落地安装尺寸 Foot-mounted dimension			壁挂安装尺寸 Wall-mounted dimension				备注 Remarks
			W	H	H1	H2	D	a1	b1	d1	a2	a3	b2	d2	
B 版本 Version B	G1	PH300.090.23BRMF	300	1445	1180	200	500	250	430	14	220	150	1135	13	参考图三 Figure 3
		PH300.185.43BRMF													
		PH300.200.43BRMF													
		PH300.220.43BRMF													
	H1	PH300.250.43BRMF	330	1595	1330	200	545	280	475	14	220	185	1275	13	
	I1	PH300.280.43BRMF	325	1495	1230	200	545	275	470	14	225	185	1175	14	
		PH300.315.43BRMF													
J1	PH300.350.43BRMF	335	1720	1455	200	545	285	470	14	240	200	1380	14		
	PH300.400.43BRMF														
	PH300.450.43BRMF														

液压系统最大压力 (bar) Max Pressure of Hydraulic System		175		160		140	
油泵排量 (cc) Pump Displacement	额定转速 (rpm) Rated Speed	电机型号 Servo Motor Code	驱动器型号 Servo Drive Code	电机型号 Servo Motor Code	驱动器型号 Servo Drive Code	电机型号 Servo Motor Code	驱动器型号 Servo Drive Code
16	1500	E01004F153	PH300.011.43ARMF	E01004F153	PH300.011.43ARMF	E01004F153	PH300.011.43ARMF
	2000	E01004F203	PH300.011.43ARMF	E01004F203	PH300.011.43ARMF	E01004F203	PH300.011.43ARMF
25	1500	E01005F153	PH300.015.43ARMF	E01004F153	PH300.011.43ARMF	E01004F153	PH300.011.43ARMF
	2000	E01005F203	PH300.018.43ARMF	E01004F203	PH300.011.43ARMF	E01004F203	PH300.011.43ARMF
32	1500	E01005F153	PH300.015.43ARMF	E01005F153	PH300.015.43ARMF	E01005F153	PH300.015.43ARMF
	2000	E01005F203	PH300.018.43ARMF	E01005F203	PH300.018.43ARMF	E01005F203	PH300.018.43ARMF
40	1500	E01007F153	PH300.018.43ARMF	E01007F153	PH300.018.43ARMF	E01005F153	PH300.015.43ARMF
	2000	E01007F203	PH300.022.43ARMF	E01007F203	PH300.022.43ARMF	E01005F203	PH300.018.43ARMF
50	1500	E01008F153	PH300.022.43ARMF	E01007F153	PH300.018.43ARMF	E01007F153	PH300.018.43ARMF
	2000	E01008F203	PH300.030.43ARMF	E01008F203	PH300.030.43ARMF	E01007F203	PH300.022.43ARMF
63	1500	E01010F153	PH300.030.43ARMF	E01010F153	PH300.030.43ARMF	E01008F153	PH300.022.43ARMF
	2000	E01010F203	PH300.030.43ARMF	E01010F203	PH300.030.43ARMF	E01008F203	PH300.030.43ARMF
80	1500	E01013F153	PH300.030.43ARMF	E01012F153	PH300.030.43ARMF	E01010F153	PH300.030.43ARMF
	2000	E01013F203	PH300.037.43ARMF	E01012F203	PH300.037.43ARMF	E01010F203	PH300.030.43ARMF
100	1500	E01220F153	PH300.045.43ARMF	E01215F153	PH300.037.43ARMF	E01013F153	PH300.030.43ARMF
	2000	E01220F203	PH300.055.43ARMF	E01215F203	PH300.045.43ARMF	E01013F203	PH300.037.43ARMF
125	1500	E01225F153	PH300.055.43ARMF	E01220F153	PH300.045.43ARMF	E01220F153	PH300.045.43ARMF
	2000	E01225F203	PH300.055.43ARMF	E01225F203	PH300.055.43ARMF	E01220F203	PH300.055.43ARMF
160	1500	E01235F153	PH300.075.43ARMF	E01230F153	PH300.055.43ARMF	E01225F153	PH300.055.43ARMF
	2000	E01235F203	PH300.090.43ARMF	E01230F203	PH300.075.43ARMF	E01225F203	PH300.055.43ARMF

环境温度 $T_{amb}[^{\circ}C]$: 30°C

以上选型适用于注塑机，其他行业液压选型请向菲仕咨询。

对于保压时间或高速高压较长的场合，具体选型请向菲仕咨询。

All codes selected as above apply to injection molding machine, if you need more information, please contact with us.

Regarding long holding pressure or high speed/high pressure applications, please contact with us for more details.

Connection Diagram

注塑机专用接线图

注意:

185KW 及以上需要外接制动单元。

160KW 及以下无需外接制动单元，只需在 B1 和 B2 间接制动电阻。

Note:

Servo drive's power $\geq 185kw$: need to connect brake unit separately.

Servo drive's power $\leq 160kw$: only need to connect brake resistor between B1 & B2.

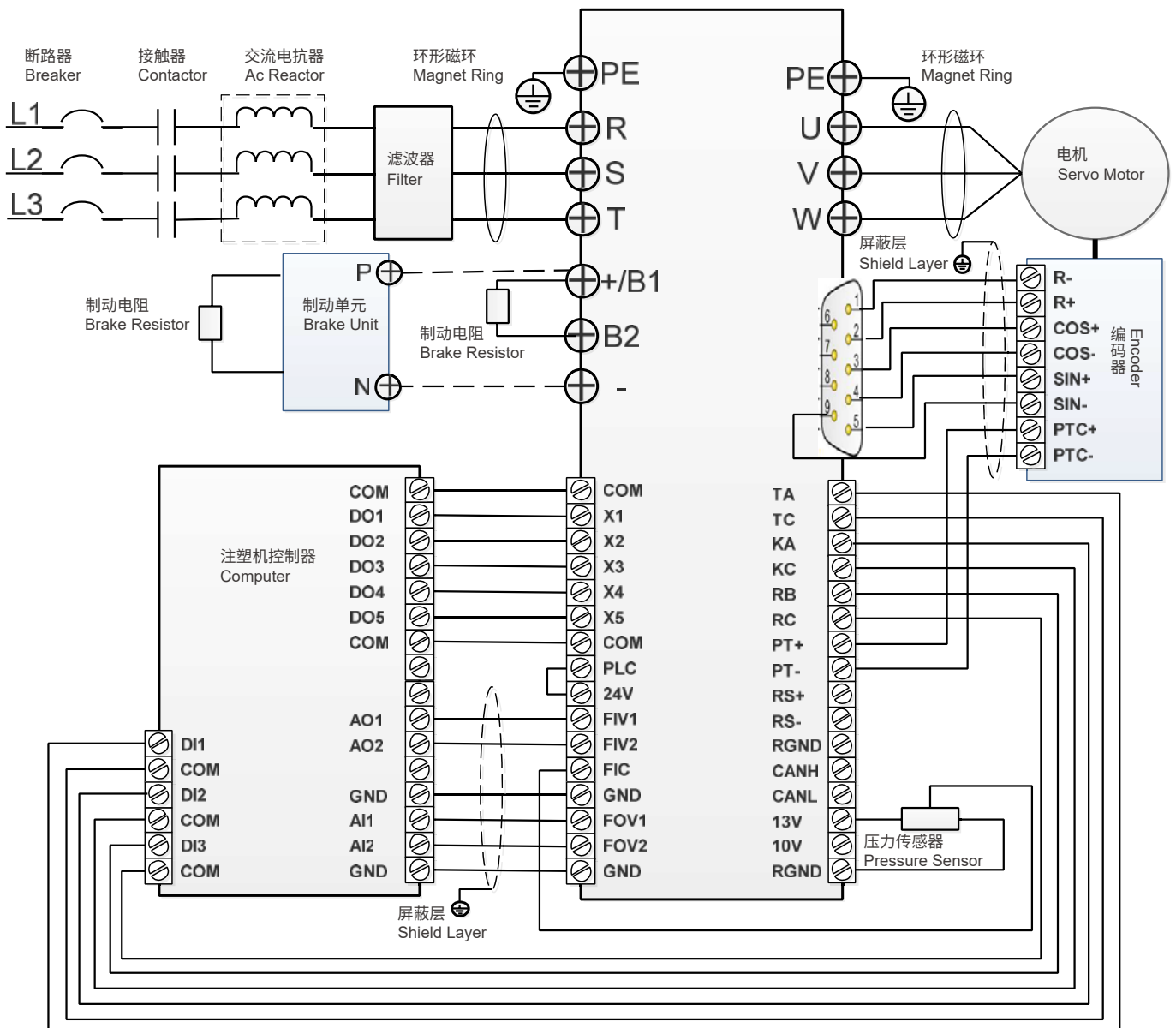

菲仕总部 PHYSIS HEADQUARTER

宁波菲仕技术股份有限公司

Ningbo Physis Technology Co., Ltd.

浙江省宁波市北仑区小港安居路 308 号

No.308, Xiaogang Anju Road, Beilun District, Ningbo, China

总台热线 /Tel: +0086-(0)574-26922600

菲仕生产基地 MANUFACTURING BASE

宁波菲仕运动控制技术有限公司

Physis Motion Control Ningbo Co., Ltd.

浙江省宁波市杭州湾新区滨海二路 248 号

No.248, 2nd Binhai Road, Hangzhou Bay New Zone, Ningbo China

总台热线 /Tel: +0086-(0)574-23459000

国内业务 Domestic Sales

销售热线 /Tel: +0086-(0)574-26922572

邮箱 /E-mail: lois @physis.com.cn

海外业务 Overseas Sales

销售热线 /Tel: +0086-(0)574-23459168

邮箱 /E-mail: andy@physis.com.cn

售后服务 After Sales

服务热线 /Tel: +0086-(0)574-23459183

邮箱 /E-mail: Aftersales@physis.com.cn

由于产品的不断更新和改进，本产品型录中的部分产品数据信息会产生变化，为了能提供更好的服务，建议您在查阅本产品型录的同时，请联系我们，以便您及时获得最新的资讯。

All technical data, drawings and product information contained here may be subject to change, in order to provide you with a continuously improved products, please contact with us for up to date information.



扫一扫关注
获取更多资讯